

Peri Loucopoulos  
Selmin Nurcan  
Hans Weigand

# CAiSE 2015 Doctoral Consortium

Proceedings of the CAiSE'2015 Doctoral Consortium at  
the 27<sup>th</sup> International Conference on Advanced  
Information Systems Engineering (CAiSE)

Stockholm, Sweden, 8-12 June, 2015



## Preface

CAiSE is a well-established highly visible conference series on Information Systems Engineering.

The CAiSE 2015 Doctoral Consortium is the 22nd Doctoral Consortium of a series held in conjunction with the CAiSE conference series. It is intended to bring together PhD students working on foundations, techniques, tools and applications of Information Systems Engineering and provide them with an opportunity to present and discuss their research to an audience of peers and senior faculty in a supportive environment, as well as to participate in a number of plenary sessions with Information Systems academics.

The goals of the Doctoral Consortium are:

- To provide fruitful feedback and advice to the selected PhD students on their research project.
- To provide the opportunity to meet experts from different backgrounds working on topics related to the Information Systems Engineering field.
- To interact with other PhD students and stimulate an exchange of ideas and suggestions among participants.
- To provide the opportunity to discuss concerns about research, supervision, the job market, and other career-related issues.

Participants to the Doctoral Consortium were current doctoral students within a recognized university, with at least 6-12 months work remaining before expected completion (and at least 12 months of work already performed).

The CAiSE 2015 Doctoral Consortium received 14 submissions from 11 countries (Austria, Belgium, Bosnia and Herzegovina, Brazil, Canada, France, Germany, Italy, Macedonia, Morocco, Tunisia).

The management of paper submission and reviews was supported by the EasyChair conference system. All doctoral papers received two reviews from members of the Program Committee and each one was also considered by the Doctoral Consortium Chairs. Eventually, 9 doctoral papers were presented during CAiSE'2015 and are included in these proceedings.

We would like to express our gratitude to the members of Doctoral Consortium Program Committee for their efforts in providing very thorough evaluations of the submitted doctoral papers. We wish also to thank all PhD students who submitted papers to the Doctoral Consortium for having shared their work with us.

Last but not least, we would like to thank the CAiSE 2015 Program Committee Chairs and the Local Organisation Committee for their support.

June 12th, 2015  
Peri Loucopoulos, Selmin Nurcan, Hans Weigand  
CAiSE 2015 Doctoral Consortium Chairs



## **Program Committee Members**

- Rebecca Deneckere, Université Paris 1 Panthéon-Sorbonne, France
- Sergio Espana, Universitat Politècnica de València, Spain
- Jānis Grabis, Riga Technical University, Latvia
- Giancarlo Guizzardi, Federal University of Espírito Santo, Brazil
- Renata Guizzardi, Universidade Federal do Espírito Santo, Brazil
- Willem-Jan van den Heuvel, The Netherlands
- Christian Huemer, Vienna University of Technology, Austria
- Manfred Jeusfeld, University of Skövde, Sweden
- John Krogstie, Norwegian University of Science and Technology, Norway
- Kalle Lyytinen, Case Western reserve University, USA
- Haralambos Mouratidis, University of Brighton, UK
- Anne Persson, University of Skövde, Sweden
- Geert Poels, Ghent University, Belgium
- Manfred Reichert, University of Ulm, Germany
- Hajo Reijers, Eindhoven University of Technology, The Netherlands
- Samira Si-Said Cherfi, CNAM, France
- Pnina Soffer, University of Haifa, Israel
- Janis Stirna, Stockholm University, Sweden
- Barbara Weber, University of Innsbruck, Austria
- Jelena Zdravkovic, Stockholm University, Sweden

## **CAiSE PhD Award**

From CAiSE 2015, a “CAiSE PhD Award” has been initiated. Each year, an award will be offered to a PhD defended in the last two years. The award will consist of a free full registration (5 days) to the next two CAiSE conferences.

The PhD thesis submitted for the award will be reviewed by a standing committee composed of the members of the CAiSE Advisory Committee, the CAiSE Steering Committee and on-going CAiSE Program Committee Chairs.

The condition to apply for the “CAiSE PhD Award” is having participated as an author to a previous CAiSE Doctoral Consortium and having defended the PhD thesis in the last two years.

The candidates to the CAiSE PhD Award should be nominated by their thesis advisor or the application of the candidate should be accompanied by a support letter from the thesis advisor.

Remain connected to the on-going CAiSE web site to be informed about the application process to the CAiSE PhD Award of the given year.



## Table of Contents

Process Verification and Synthesis - The Use Case of Commissioning Processes in the Automobile Industry . . . . .	1
<i>Richard Mrasek</i>	
Supporting and assisting the execution of knowledge-intensive processes . .	10
<i>Steven Mertens</i>	
Tactical Management in Focus: Adaptability and Information Systems . .	19
<i>Renata Petrevska Nechkoska</i>	
Situational Method Engineering in ERP implementation methodologies . .	28
<i>Adnan Kraljić</i>	
Data Reduction in Monitored Data . . . . .	39
<i>Xuesong Peng</i>	
Enrichment of Business Process Management with External Data . . . . .	47
<i>Pierre-Aymeric Masse</i>	
Integrating the Internet of Things with Business Process Management: A process-aware framework for Smart Objects . . . . .	56
<i>Giovanni Meroni</i>	
Towards a Framework for Feature Deduplication during Software Product Lines Evolution . . . . .	65
<i>Amal Khtira</i>	
Safe Management of Software Configuration . . . . .	74
<i>Markus Raab</i>	





# Process Verification and Synthesis – The Use Case of Commissioning Processes in the Automobile Industry

Richard Mrasek

Karlsruhe Institute of Technology (KIT)  
Institute for Program Structures and Data Organization  
76131 Karlsruhe, Germany  
richard.mrasek@kit.edu

Supervisor: Prof. Dr.-Ing. Klemens Böhm

**Abstract.** In the automobile industry, commissioning process models describe the end-of-line manufacturing and testing of vehicles. Due to the increase of electronic components in modern vehicles, the process models tend to become more complex. At the same time the number of different model series is constantly increasing leading to a larger amount of process models. The increase in process models and complexity lead to higher cost for the process design and decrease the quality of the individual process model. In this Ph.D. project we want to support process modeling. *First*, by developing a framework to test if a given process model fulfills all properties required (*process verification*). *Second*, we want to support the process design by approaches for a semiautomatic generation of process models (*process synthesis*). *Third*, for *process verification* and *process synthesis* one needs a *specification* of the allowed behavior of the process models.

**Keywords:** Commissioning Processes, Process Verification, Process Synthesis, Business Process Modeling

## 1 Introduction

In the automobile industry, commissioning process models describe the end-of-line manufacturing and testing of vehicles. Process developers define these processes with development tools. Workflow Management Systems (WfMS), here referred to as Diagnostic Frameworks, execute these processes [25]. Vehicle commissioning includes, say, to check for each vehicle produced, whether all its Electronic Control Units (ECU) are integrated correctly and to put them into service. ECUs are components built in to the vehicle which control specific functionalities of the car, e. g., the ECU MOT controls the engine electronics. Each ECU needs to be tested and put into operation, e. g., by installing certain software. To this end, the WfMS executes several tasks for each ECU. Tasks can be executed automatically like the configuration of the control unit, or they may require a factory worker equipped with a hand terminal. Figure 1 shows the general architecture of a

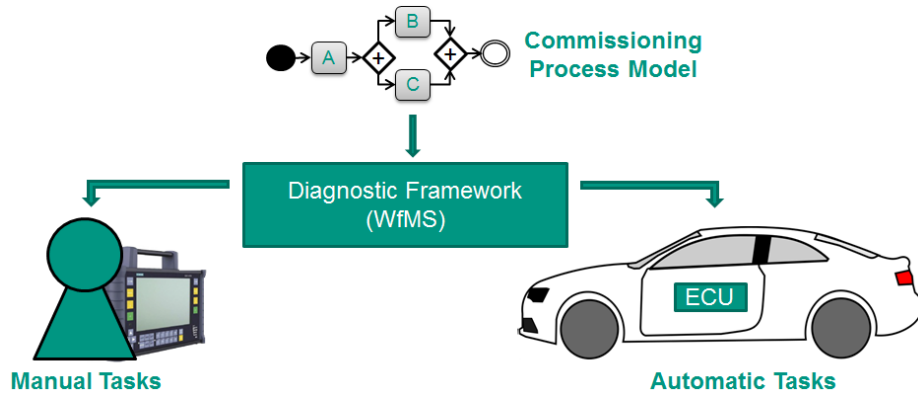

**Fig. 1.** The Simplified Architecture of a Diagnostic System

diagnostic system. Commissioning processes have the characteristic to be complex. Typically there are hundreds of tasks for each vehicle, arranged in up to 14 parallel lanes.

Due to the increase of electronic components in modern vehicles, the process models tend to become more complex. At the same time the number of different model series is constantly increasing leading to a larger amount of process models. In this Ph.D. project we want to support process modeling, making research on testing schemes, whether a given process model fulfills all properties required (*process verification*), and on approaches for a semiautomatic generation of process models (*process synthesis*). For *process verification* and *process synthesis* one needs *specification* of the allowed behavior of the process models. Formally, let  $P$  be the process model of a commissioning process, and  $\mathcal{L}_P$  denote the complete log of the process, i. e., all possible traces of the process model. Let  $\mathcal{C}$  denote the set of all traces allowed by the properties. We can now define *Specification*, *Verification*, and *Synthesis* as follows:

*Specification* : Define the set of allowed traces  $\mathcal{C}$  (1)

*Verification* : For a given process model  $P$  check if  $\mathcal{L}_P \subseteq \mathcal{C}$  (2)

*Synthesis* : Generate a process model  $P$  with  $\mathcal{L}_P \subseteq \mathcal{C}$  (3)

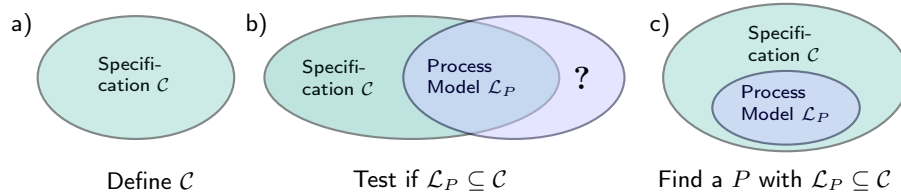

**Fig. 2.** Our Problem Statements Specification (a), Verification (b), and Synthesis (c).

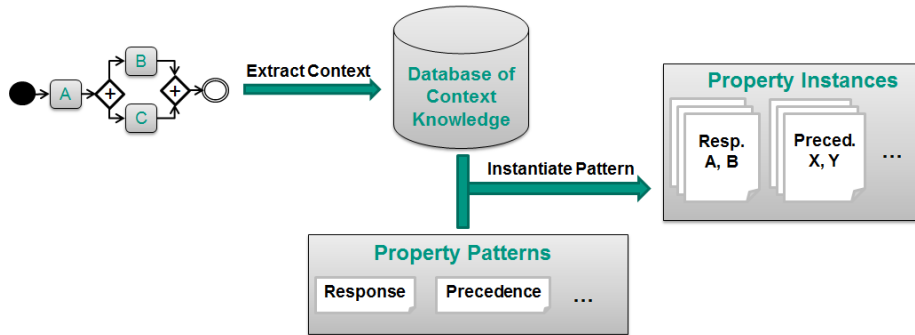

**Fig. 3.** The Approach of the Instantiating of the Contextual Property Pattern

## 2 Specification

Before *verification* and *synthesis* can take place we have to *specify* the allowed behavior  $\mathcal{C}$ . The allowed behavior is induced by a set of properties  $\Phi$ . The allowed behavior  $\mathcal{C}$  consists of all traces fulfilling the properties  $\Phi$ , i. e.,  $\mathcal{C} := \{t \mid \forall \phi \in \Phi : t \models \phi\}$ . The specification of the properties  $\Phi$  gives way to several challenges: *First*, the knowledge which characteristics a commissioning process should fulfill is typically distributed among several employees in different departments. Often documentation is missing and properties merely exist in the minds of the process modelers. *Second*, the properties frequently are context-sensitive, i. e., they only hold in specific contexts of a commissioning process. For example, certain tasks require a protocol to communicate with control units for testing depending on the factory the testing takes place. Due to this context-sensitiveness, the number of properties is very large, but it consists of a lot of variants with only small differences. This causes maintenance problems [11]. For instance the new generation of an electronic control unit in the car uses a different communication protocol than the previous generation. This protocol change leads to a large set of new properties and render several properties invalid. *Third*, to apply an automatic verification or synthesis technique, it is necessary to specify the properties in a formal language such as a temporal logic [21]. With vehicle-commissioning processes as well as in other domains, see for instance [6], [15], specifying the properties in this way is error-prone and generally infeasible for domain experts who are not used to formal specifications.

### Research Question:

How to generate the correct set of properties given a process model and context.

### Approach:

In [19] we have presented an approach to address these challenges based on our real-world use case of vehicle-commissioning processes. More specifically, we use

the following approach: We have analyzed the properties occur for vehicle commissioning processes as well as the respective context information. We have observed that there are few patterns to which these properties adhere to. We propose to explicitly represent these patterns, rather than each individual property. Next, we develop a model of the context knowledge regarding vehicle-commissioning processes. Here, *context* are the components of a vehicle, their relationships and the constraints which the vehicle actually tested and configured must fulfill. We let a relational database manage the context information. To populate it, we use several sources, e. g., information on the vehicle components from production planning, constraints from existing commissioning processes, and information provided by the process designers themselves. Our framework uses this information to generate process-specific instances of the property patterns. Figure 3 illustrates the approach.

### Evaluation:

Our goal is for a user-friendly approach for the specification of properties, i. e., high usability. According to ISO 9241-11 [10] usability has three different aspects to be evaluated separately: *Effectiveness* (Whether the user can complete his tasks and achieve the goals), *Efficiency* (The amount of the resource usage to achieve the goals), *Satisfaction* (The level of comfort the users experience achieving the goals). The *effectiveness* is proven by testing if the resulting specification gives a meaningful result for the later verification or synthesis. Our approach has shown to be able to generate the hundreds of property instances in under one second, proving a high *efficiency*. For the *satisfaction* we have used an established questionnaire the System Usability Scale (SUS). The result states that our approach leads to a high satisfaction with results higher than the average.

## 3 Verification of Process Models

Verification means to test if the behavior of the process model  $\mathcal{L}_P$  complies with the allowed behavior  $\mathcal{C}$ . The verification is not trivial because, it is not possible to explicitly generate  $\mathcal{C}$  and  $\mathcal{L}_P$ .  $\mathcal{C}$  is in general not bounded and the size  $\mathcal{L}_P$  can increase exponentially with the size of the process model, or it can even be infinite. This is well known as state-space explosion [4]. It leads to unacceptable runtime or renders the verification not executable. This is often caused by parallel branches in the model. To overcome this problem, reduction techniques can be used, either (a) during construction of the  $\mathcal{L}_P$  or (b) on the level of the process model already. Approaches like stubborn set reductions [22] fall into the first category. However, many of the industrial processes to be analyzed in our evaluation are too large to be verified only with stubborn set reductions. Even with stubborn set reduction, there are more than 1 million traces in 78% of the processes we have evaluated; thus, verification has not been possible in reasonable time. Regarding (b), only few proposals exist, although preprocessing of the process model is promising to achieve a significant reduction of the state

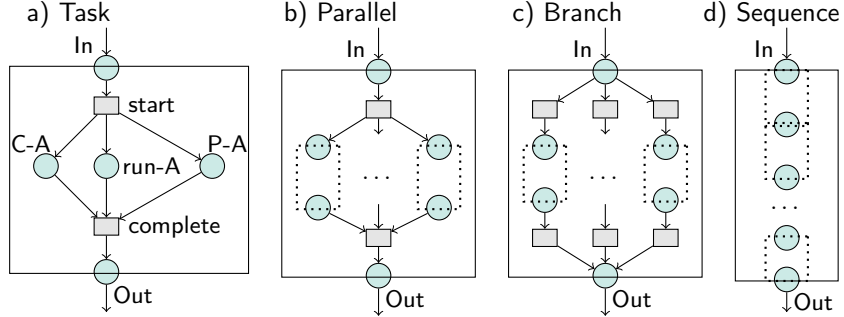

Fig. 4. The Simplified Templates for Different OTX Elements, from [19].

space. An example is given in [2]. They specify the requirements in BPMN-Q. BPMN-Q is a visual language to query business process models. [2] however is not expressive enough to express all requirements from our real-world application scenario. Furthermore, they apply reduction rules on the process schema in an iterative way. After each reduction step, another reduction rule may become again applicable. Thus, a rescan of the whole process may be necessary after each step, rendering this kind of approach expensive. In the industrial setting envisioned here, it is necessary to verify hundreds of properties per process, in short time. Compared to the processes dealt with by others [7], ours are much larger and more complex, leading to an exploding state space.

### Research Questions:

There are two research question of our concerns. First, how to allow the verification for the industry standard OTX. Second, how to verify a process model having a state space to large to generate explicitly.

### Approach:

In order to allow the verification one have to generate the traces  $\mathcal{L}_P$  for a process model. It is not possible to directly generate  $\mathcal{L}_P$  for a commissioning process in the notation of OTX. Therefore, we developed a mapping of OTX to Petri net suitable for our verification. For the transformation we define for each object in OTX a Petri net subnet. For the transformation we parse the process model of a OTX process model and generate a Petri net according to the templates. Figure 4 shows the simplified template for four OTX elements.

The verification of our real commissioning processes has performance issues. Verification means to check if a process model  $P$  complies with all required properties  $\Phi$ , formally to check  $\forall \phi \in \Phi : P \models \phi$ . Our basic idea is to generate

a smaller process model  $P_\phi$  for each property  $\phi$ . The reduction should preserve each property, or formally:

$$\forall \phi \in \Phi : P \models \phi \Leftrightarrow \forall \phi \in \Phi : P_\phi \models \phi$$

In [16] we showed an algorithm that traverses the process model and identifies the regions of the process that are relevant for verification of a given complex property  $\phi$ . Identifying the relevant regions of a process is far from trivial. Even an elementary task cannot be removed in all cases. Our approach features a criterion for process-graph reduction, which we refer to as relevance function. The algorithm proposed creates a formal, reduced representation of the process for each property. In particular, the reduction of parallel regions help to decrease the size of the state space and hence the runtime of the verification.

### Evaluation

The approach has been evaluated with commissioning process models for testing newly produced vehicles in the factories of a German car manufacturer. One result is that even complex processes with many parallel branches can be verified in less than 10 seconds on a commodity PC. Our approach is able to detect property violations in realistic commissioning processes.

## 4 Process Syntheses

Process Syntheses is to find a process model  $P$  with the complete log  $\mathcal{L}_P \subseteq \mathcal{C}$ . To allow a transformation into OTX we are looking for a block-based process model. As we show in [18] it is in general not possible to find a block-based process model with  $\mathcal{L}_P = \mathcal{C}$ . Furthermore, as we see in our use case, it is not possible to find a single best process model  $P$ . In general, a vast amount of process models is possible.

### Research Question:

How to synthesize an acyclic process model from a declarative specification that is good according to a given quality criteria.

### Approach:

The approach presented later at the conference [18] generates a process model from a declarative specification. The input to our approach is a declarative specification in graph forms the Ordering Relationship Graph (org). In [17] we show how to generate such a graph from other specification languages. First we apply a modular decomposition on the graph. The technique decomposes the graph in several subgraph of different granularity. The subgraphs called modules are arranged in a hierarchical form, called Modular Decomposition Tree (MDT). The modular decomposition allows us to detect the under-specified parts of the specification. We use a probabilistic search to find a good solution for the under-specified regions according to a predefined fitness function.

## Evaluation:

As we show in the evaluation with thousands of non-trivial process models, our approach is efficient, i. e., is able to test thousands of models in under a second. We use a real life specification for commissioning from our industrial partner in our evaluation. On average, our approach nearly halves the processing time compared to the reference processes which already are the output of a careful, intellectual design. It is able to handle complex real-world specifications containing several hundred dependencies as well as more than one hundred tasks. In our evaluation, the process models generated contain between 98 and 185 tasks, and their arrangement typically is nontrivial.

## 5 Related Work

Recent research works present different graphical notations for the property specification, e. g., for the verification. See, for example, the Compliance Rule Graphs (CRG)[15], or BPMN-Q [2]. The graphical specification allows for a more user-friendly and intuitive specification compared to the textual specification, say, in a temporal logic. But they do not support the major challenges of our work: The context sensitivity and the distributed knowledge. [6] introduce a set of property patterns for the specification. They share some common patterns with our set of commissioning property patterns but lack necessary domain specific information.

A related field of research is business process compliance [13]. Compliance is ensuring that a process model is in accordance with prescribed norms [20], e. g., Sarbanes-Oxley, Basel II, HIP AA. In general, two approaches toward process compliance exists. Expensive manual checks (after-the-fact) and automated detection. For the automated detection the norms have to be specified formally. As well as in our use case, specifying the norm leads to maintenance problems [14]. Approaches exist to ensure the compliance of an existing process model by, e. g., model checking [2][12][8] or to synthesize a new process model which complies with the norm [3][9].

A lot of work is done in the verification of the soundness property for process models. The soundness verification leads to a similar state space explosion compared to our approach. [1][5] tries to handle the state space explosion by using reduction rules on the process-model level. These reduction rules are not applicable for our use case, in general. Other works like the stubborn set reduction [23, 22], try to reduce the state-space generation of a Petri net. These techniques are orthogonal to our reduction and can be used in combination. Our experiments have shown that these low level reductions alone are not sufficient for our process models.

[24] and [3] synthesize a process model from a declarative specification. To this end, [24] uses a collection of small state machines representing property patterns, and [3] from LTL formulas. The approach of [24] does not consider the case of a under specification, i. e., more than one process model is possible for

the specification. [3] requires a manual solving of these cases. Both approaches indicate performance issues when dealing with large specifications like the ones in our use case.

## 6 Conclusions

In this Ph.D. project we research the *specification*, *verification* and *synthesis* of commissioning process models in the automobile industry. The verification frameworks are quite mature and actually applied in the factory of our industry partner. The framework has shown to be able to increase the quality of the process models. The first results of the *synthesis* show a great potential in applying these techniques. In the last year of these project we plan to apply the *synthesis* technique for the design of the new process models for the next generation of vehicles.

## References

1. W. M. P. v. d. Aalst, A. Hirschnall, and H. M. W. Verbeek. “An Alternative Way to Analyze Workflow Graphs”. In: *Advanced Information Systems Engineering*. 2002.
2. A. Awad, G. Decker, and M. Weske. “Efficient Compliance Checking Using BPMN-Q and Temporal Logic”. In: *Business Process Management*. 2008.
3. A. Awad et al. “An Iterative Approach for Business Process Template Synthesis from Compliance Rules”. In: *Advanced Information Systems Engineering*. 2011.
4. E. M. Clarke, O. Grumberg, and D. Peled. *Model Checking*. 1999.
5. B. F. van Dongen, W. M. P. v. d. Aalst, and H. M. W. Verbeek. “Verification of EPCs: Using Reduction Rules and Petri Nets”. In: *Advanced Information Systems Engineering*. 2005.
6. M. B. Dwyer, G. S. Avrunin, and J. C. Corbett. “Property Specification Patterns for Finite-state Verification”. In: *Proceedings of the Second Workshop on Formal Methods in Software Practice*. 1998.
7. D. Fahland et al. “Instantaneous Soundness Checking of Industrial Business Process Models”. In: *Business Process Management*. 2009.
8. A. Forster et al. “Verification of Business Process Quality Constraints Based on Visual Process Patterns”. In: *First Joint IEEE/IFIP Symposium on Theoretical Aspects of Software Engineering, 2007. TASE '07*. 2007.
9. S. Goedertier and J. Vanthienen. “Designing Compliant Business Processes with Obligations and Permissions”. In: *Business Process Management Workshops*. 2006.
10. *ISO 9241-11, Ergonomics of Human-Computer Interaction - Part 11: Guidance on Useability*. 1998.
11. S. Kabicher, S. Rinderle-Ma, and L. T. Ly. “Activity-Oriented Clustering Techniques in Large Process and Compliance Rule Repositories”. In: *Proc. BPM'11 Workshops*. 2011.
12. Y. Liu, S. Müller, and K. Xu. “A static compliance-checking framework for business process models”. In: *IBM Systems Journal* (2007).
13. L. T. Ly. *SeaFlows - a compliance checking framework for supporting the process lifecycle [Elektronische Ressource] / Linh Thao Ly*. 2013.



14. L. T. Ly et al. "Compliance of Semantic Constraints - A Requirements Analysis for Process Management Systems". In: 2008.
15. L. T. Ly et al. "SeaFlows Toolset – Compliance Verification Made Easy for Process-Aware Information Systems". In: *Information Systems Evolution*. 2011.
16. R. Mrasek, J. Mülle, and K. Böhm. "A new verification technique for large processes based on identification of relevant tasks". In: *Information Systems* (2014).
17. R. Mrasek, J. Mülle, and K. Böhm. *Automatic Generation of Optimized Process Models from Declarative Specifications*. Technical Report 2014-15. KIT Scientific Publishing, 2014.
18. R. Mrasek, J. Mülle, and K. Böhm. "Automatic Generation of Optimized Process Models from Declarative Specifications". In: *Advanced Information Systems Engineering*. 2015.
19. R. Mrasek et al. "User-Friendly Property Specification and Process Verification - a Case Study with Vehicle-Commissioning Processes". In: *Business Process Management*. 2014.
20. S. Sadiq, G. Governatori, and K. Namiri. "Modeling Control Objectives for Business Process Compliance". In: *Business Process Management*. 2007.
21. H. Schlingloff, A. Martens, and K. Schmidt. "Modeling and Model Checking Web Services". In: *Electronic Notes in Theoretical Computer Science* (2005).
22. K. Schmidt. "Stubborn Sets for Model Checking the EF/AG Fragment of CTL". In: *Fundam. Inf.* (2000).
23. K. Schmidt. "Stubborn Sets for Standard Properties". In: *Application and Theory of Petri Nets 1999*. 1999.
24. J. Yu et al. "Synthesizing Service Composition Models on the Basis of Temporal Business Rules". In: *Journal of Computer Science and Technology* (2008).
25. W. Zimmermann and R. Schmidgall. *Bussysteme in der Fahrzeugtechnik - Protokolle, Standards und Softwarearchitektur*. 2011.

# Supporting and Assisting the Execution of Knowledge-intensive Processes

Steven Mertens

Department of Business Informatics and Operations Management  
Faculty of Economics and Business Administration  
Ghent University, Tweekerkenstraat 2, 9000 Ghent, Belgium  
steven.mertens@ugent.be

Supervisors: Frederik Gailly and Geert Poels

**Abstract.** Business processes management (BPM) offers the tools to model business processes. In order to implement and support the created process models, business process management systems (BPMS) have been introduced. Such a system handles the coordination between the process actors and makes sure that the real process is executed in conformance to the specified model. The existing BPMSs focus on tightly framed processes and offer little to no support for less tightly framed processes. Knowledge-intensive processes (KiP) are an important class of such loosely framed processes. In this research project we want to develop a BPMS architecture that offers both support and assistance during the execution of KiPs. Some components of traditional BPMSs can be reused, but other components will have to be adapted or even created to fit the new purpose. In this paper we present the problem description, research goals, methodology and current status of the research project.

**Keywords:** Knowledge-intensive Processes, Business Process Management Systems, Decision Support

## 1 Introduction

A business process is a set of one or more connected activities which collectively realize a particular business goal. Business process management (BPM) includes concepts, methods, and techniques to support the design, administration, configuration, enactment, and analysis of business processes [1]. Process models are used to facilitate communication between business stakeholders, to analyze and redesign the as-is business process and finally are put into execution by the Business Process Management Systems (BPMS) of the organization. The goals of applying BPM are a better understanding of the process and to continually upon it.

Business processes can be classified according to level of utilization of process models [2]. First, unframed processes do not have an explicit process model (e.g., collaborative processes supported by groupware systems). Next, a process is ad-hoc framed if it has a predefined process model, but this model is only used a small num-

ber of times before it is discarded or changed (e.g., adaptive case management). When the process is a bit more structured it is called loosely framed. This entails that a process model allowing ‘the normal way of doing things’ and some deviations is a priori defined by way of a set of constraints. Lastly, a tightly framed process consistently follows a predefined and unambiguous process model (e.g., traditional process engines and workflow management systems).

The design and administration of tightly framed processes is supported by well-known imperative process modeling languages like UML, BPMN, and EPC’s. The design and administration of loosely framed business processes, however, is only supported by a limited set of declarative process modeling languages (e.g. Declare). While imperative approaches focus on explicitly defining the exact path of activities to reach the process goals, declarative approaches determine only the activities that may be performed as well as constraints prohibiting undesired behavior [3].

The configuration and enactment of tightly framed business processes is supported by BPMS, which enable the execution of the business process by means of imperative process model. The configuration and enactment of loosely framed P2P processes is harder to realize for several reasons [4]. For one, the development of declarative process modeling languages is still in its infancy. Different declarative process modeling approaches have been proposed which support the specification of different business concerns, the specification of different constraint types and use different reasoning paradigms [5]. Moreover, in contrast to imperative process modeling languages, it is not clear how declarative process models in general can be transformed into executable models that can be used directly by the BPMS. Additionally, the participants of loosely framed P2P processes are primarily knowledge workers (e.g., doctors) who decide in which order activities need to be performed based on business data and past experience. As a consequence the configuration and implementation of these processes requires a tight integration of processes data, business data and users. Currently available BPMSs have their origin in workflow management systems, which are primarily used to support routine and structured processes and, as a consequence, do not support this kind of integration.

The general objective of this research project is the specification of a BPMS architecture for KiPs. This requires the development of concepts, methods and techniques for the configuration, enactments and run-time analysis of knowledge-intensive business processes (KiPs). Different BPM researchers have recently recognized the need to extend existing techniques to support KiPs [3, 5, 6]. KiPs correspond to loosely framed person-2-person processes and are becoming more and more relevant. A typical example of an environment where a lot of KiPs are executed is a healthcare organization. A lot of healthcare processes are loosely framed person-2-person processes in which the doctor and nurse are the knowledge workers who will decide which path the patient will follow, taking into account certain preferences, conditions and norms.

The decision making process of knowledge workers is considered to be the essence of KiPs. This leads to an important secondary goal of this research project: offering decision support during the execution of these processes. This decision support will be based on a combination of existing techniques from operations research and knowledge management. The former has been used in the past by the BPM discipline

for model-based process analysis (e.g. simulation, queuing theory). The latter has mainly been used in the context of process mining, which aims to discover, monitor and improve real processes by extracting knowledge from event logs [7]. Process mining techniques have been successfully used to analyze the logs of business processes which already have been completed (i.e., offline). In this project we focus on knowledge extraction technique that can be used for online decision support. Some techniques for online decision support using process mining techniques have been proposed [8–10], but it still remains a challenge in the context of KiPs. Note, the ultimate goal is not to automate decision making processes (i.e., expert systems), but rather to offer support to the knowledge workers during a decision making process.

## **2 Research goals**

The general objective of this project is translated into four research goals: developing an architecture for KiP management systems, making declarative process models executable, making tacit decision knowledge explicit by analyzing the decisions of knowledge workers and assisting knowledge workers when making path decisions.

### **2.1 Developing an architecture for KiP management systems**

A standard architecture for workflow management systems has been published in 1995 [11]. It is our intent to create a similar architecture for KiPs. The three research goals discussed below are components that we identified as missing in the original architecture. Additionally, we need to evaluate which components of the original architecture will be useful in this new context. The resulting architecture will thus integrate the outcomes of the other three research goals, as well as some existing components and possibly other to be determined components inherent to KiPs.

### **2.2 Making declarative process models executable**

Business process models typically follow one or more modeling perspectives [12]. For example, analytical BPMN models focus on modeling the activities (i.e. functional perspective) and control flow (i.e. behavioral perspective) of business processes, and less on the data (information perspective) and resources (organizational perspective) needed by these processes. Making a process model executable corresponds to focusing or extending a perspective which was previously not taken into account by the model. For instance, for BPMN this could be specifying how the different services can be implemented by application services (operation perspective) or how user tasks can be assigned to organizational resources (organizational perspective).

KiPs are typically modeled by means of declarative business process models which take a rule-based perspective on process models. The second research goal of this research project investigates what it means to transform a declarative process model into an executable process model. This transformation is different for declarative process models because the control flow of a KiP cannot be specified at build time,

but instead is only determined at run-time by the knowledge worker. Additionally, in the context of KiPs the different perspectives are also more integrated and, as a consequence, run-time coordination between the perspectives is needed. The execution of a specific path should take into account the rules and constraints of the KiP. On the other hand it is also influenced by the decisions made by the knowledge worker and the relevant data that is available. A possible solution is presented by Barba et al. [13], in which an enactment plan is generated from a given declarative process model by means of constraint programming. These enactment plans can be transformed directly into BPMN models [14]. An enactment plan is essentially a simple and imperative sequence of activities that complies with the declarative model. However, since only enactment plan is calculated at a time, which is insufficient to handle the dynamic and flexible nature KiP, we would have to enumerating all possible enactment plans. This is not feasible for realistic cases as this would result in an enormous amount of enactment plans. Therefore, we would like to find a way to generate a specific subset of all possible imperative models that comply with the declarative model.

### **2.3 Making tacit decision knowledge explicit by analyzing the decisions of knowledge workers**

KiPs are inherently people-centric [4]. Each knowledge worker has a specific background, expertise and experience and will leverage this to make the decision on which activity to do next during the execution of the process. These decisions are driven by the status and availability of data and knowledge objects. Traditionally in BPMS a distinction is made between application data, process-relevant data and process control data [15]. For knowledge-intensive BPMS the distinction between application-data and process-relevant data is less clear. For instance, the data of the patient (application data) in combination with the availability of resources (process-relevant data) will be used by the doctor to decide which execution path shall next be taken (process-control data). The third research goal of this project focuses on identifying knowledge management techniques that support the creation of new knowledge objects by extracting and integrating information from application, process-relevant and process control data. For example, the created knowledge object can correspond to a set of decision rules, extracted from historical process control data. This externalizes the tacit knowledge of experienced knowledge workers into guidelines for less experienced knowledge workers. These less experienced knowledge workers could in turn contribute knowledge about more state-of-the-art research or just provide an out-of-the box vision.

### **2.4 Assisting knowledge workers when making path decisions**

An apparent paradox exists between providing guidance and run-time flexibility [16]. Guidance is often thought of as forcing the user in a certain direction. In contrast, run-time flexibility can be only realized if the knowledge worker is not forced to execute a certain activity next. There is however a suitable middle ground: a BPMS offering the knowledge workers specific recommendations on what he could do next. This does

not introduce any new restrictions, as the user can still decide not to follow the recommendations. The idea of using recommendation systems during the operational support for KiPs is not new [17, 18].

A key aspect to consider when making a recommendation system is what to convey to the users. A single recommendation might be enough for smaller decisions, but in the context of KiPs this will be insufficient. A list of recommendations will be more appropriate as decision tend to be complex. This list can be provided as-is or in a specific order. The latter is preferable as it gives the users more information. Additionally, we can make the sorting criteria and predicted or known consequences explicit in a clear manner to give the user even more insight into the decision. The operations research side and the knowledge management side will both contribute to the sorting criteria. The former provides advanced analytical methods that focus on concepts like efficiency, while the latter uses the accumulated knowledge base to account for preferences and hidden norms or rules. The use of operations research techniques in recommendation systems is not completely new and has been investigated to a smaller extend by Barba et al. [13]. Similarly, Schonenberg et al. [18] have also touched the surface of using knowledge management in this context. This research project aims to find deeper roots in both areas to create a combined technique.

### 3 Methodology

In the Information Systems domain the design science research is considered as a generally accepted research methodology [19, 20]. Typically, design science research consists of the following phases: 1) motivation of the problem, 2) definition objectives of the solution, 3) design and development, 4) demonstration 5) evaluation and communication [20]. The research project must result in the identification of the requirements for the four design science artifacts which will be developed:

1. An BPMS architecture for KiPs.
2. A method for transforming declarative process models into executable models.
3. A business process recommendation generator that combines operations research and knowledge management techniques
4. A method for creating a decision knowledge base using application data, process-relevant-date and process control data

The research structure is visualized using design cycles [21] in **Fig. 1**. An engineering cycle (EC) provides the necessary steps to design and evaluate an artefact. A research cycle (RC) is responsible for resolving research related issue (e.g., establishing the state of the art for a problem, finding and adapting related techniques...) [22].

The main engineering cycle (EC1) will result in the specification of a BPMS architecture for KiPs and a prototype. This cycle has three smaller engineering cycles (EC2-EC4) and one research cycle (RC6).

In the second engineering cycle (EC2) a method for making declarative process models executable will be developed. Before we can do this, we will first need to perform the first small research cycle (RC1): identify and assess the available declara-

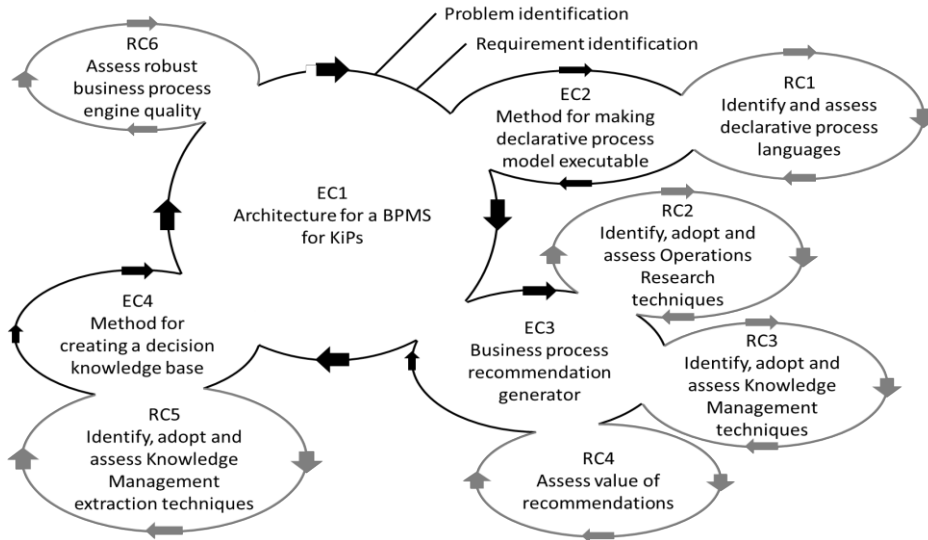

**Fig. 1.** Research structure in terms of regulative design cycles

tive process languages in the context of KiPs. If no languages are found to be sufficient, a new language will be developed during the project.

The third engineering cycle (EC3) will create the blueprints for a business process recommendation generator. This artifact should be able to generate a ranked list of recommended next activities. Two research cycles, RC2 and RC3, will identify and adopt techniques from, respectively, operations research and knowledge management. The criteria (e.g., estimated duration/cost, built-time flexibility, run-time flexibility, historic compliance...) to rank the recommendations will be produced in these cycles. In the last research cycle (RC4) of EC3, we will evaluate the value of these recommendations. The effect of having ranked recommendations will be compared to having unranked recommendations) and having no recommendations at all.

In the last engineering cycle, EC4, a method for creating a decision knowledge base will be developed. This starts by logging all relevant data (i.e., which activities are performed, resource availabilities, data generated during activities and general information about the people involved in the process). In the next phase, this logged data will be analyzed using decision mining techniques. These techniques are the outcome of RC5, which will identify, adopt and assess knowledge management techniques for extracting knowledge from raw data. The decision knowledge base will be used as input for the knowledge management techniques from RC3 for the ranking of recommendations and, if a certain previously hidden rule is confirmed by users or domain experts, will be used to improve the general process model.

Finally, the BPMS for KiPs will be evaluated in the last research cycle (RC6). The prototype of the system will be assessed in a real context (e.g., emergency department of a hospital). This assessment will primarily be performed by the actual users of the system and measure their thoughts on the potential and possible shortcomings of the system. The latter can then be examined in order to improve the system.

## 4 Current status

We started with the problem identification as was briefly discussed in the introduction of this paper. From there on we created a list of requirements for the system, which translated into EC1, EC2, EC3 and EC4. In order to evaluate the system, a target environment and evaluation setup was specified (RC6).

The first obstacle, making a declarative model executable, was tackled in combination with the recommendations. The idea arose to equate a declarative process model to a set of executable imperative process models. It is even possible to create one imperative model that is equivalent [23], but this would be a very complex and unclear model for realistic KiPs. So we decided to use a set of what we call ‘simple’ imperative process models. These models have one direct path from start to end with possibly one or more loops, even nested loops, on the way. Each imperative model in essence represents one trace with all of its variations based on repeated sequences within the trace. This is a trade-off between simplicity and the amount of possible models. These models are a bit more complex than, for example, the enactment plans proposed by Barba et al. [13], but they remain clear and understandable. At the same time, each of these models can represent a whole set of enactment plans. This dramatically reduces the number of models in the set of imperative models equivalent to a given declarative model. The chosen representation also corresponds very well to what are called sequential and iterative care processes in healthcare [24].

Theoretically, this allows us to keep track of all paths that are still available, represented by a set of imperative models, at each point during the execution of the declarative model. In practice however, we expect there to be numerous imperative models in set that is equivalent to a practical declarative model. This means that it would be very time consuming to generate the complete set, so we will possibly have to make due with knowing only a subset of the complete set of imperative models in order to keep the system usable. But since each imperative model represents many activity traces, this subset will still cover a comprehensive set of possible cases.

In the next step, we identified and compared the available declarative process modeling languages in order to find a suitable language for this purpose. All candidate languages had their shortcomings, but we eventually chose Declare [16, 25] (formerly known as ConDec), and more specifically the Declare-R extension [26], as this was at the time by far the most popular of them all (of course mainly in the research community). However, we demonstrated by way of a realistic case that Declare is insufficiently expressive to capture some the important knowledge concerning the decision making process required to model and offer guidance to users of KiPs. This resulted in a paper that is accepted to the BPMDS’15 working conference [27]. The paper also proposes the basics of a new extension, Declare-R-DMN, which bridges the Declare-R language with DMN [28]. DMN is a standard for decision logic that was just recently adopted by OMG. This will be further elaborated to create a formal metamodel and corresponding language.

In conjunction with the previous step, a blueprint for a recommendation generator was developed. This uses a variant of a genetic algorithm, called a population based meta-heuristic, to generate a subset of executable imperative process models that



conform to a given declarative process model. This subset is optimized according to fitness criteria from both the operations research and knowledge management domains. A prototype was created which currently only supports Declare, but support for Declare-R-DMN will be added as that language is formalized. A paper describing this algorithm was accepted and recently published [29].

The further elaboration of EC2 and EC3 is planned as the next phase of this research project. Meanwhile, in order to get a deeper insight in the healthcare industry, we also plan to meet with people involved in this service branch and discuss their vision on this project. As a starting point, a paper describing the intent of this project has been accepted and will be discussed at the ProCare workshop of the International Conference on Pervasive Computing Technologies for Healthcare 2015.

## References

1. Weske, M.: *Business Process Management: Concepts, Languages, Architectures*. Springer (2012).
2. Van der Aalst, W.M.P.: *Business Process Management: A Comprehensive Survey*. *ISRN Softw. Eng.* 2013, 1–37 (2013).
3. Haisjackl, C., Barba, I., Zugal, S., Soffer, P., Hadar, I., Reichert, M., Pinggera, J., Weber, B.: *Understanding Declare models: strategies, pitfalls, empirical results*. *Softw. Syst. Model.* (2014).
4. Di Ciccio, C., Marrella, A., Russo, A.: *Knowledge-Intensive Processes: Characteristics, Requirements and Analysis of Contemporary Approaches*. *J. Data Semant.* 29–57 (2014).
5. Goedertier, S., Vanthienen, J., Caron, F.: *Declarative business process modelling: principles and modelling languages*. *Enterp. Inf. Syst.* 1–25 (2013).
6. Mulyar, N., Pesic, M., van der Aalst, W.M.P., Peleg, M.: *Declarative and procedural approaches for modelling clinical guidelines: addressing flexibility issues*. *BPM Workshops. LNCS*, vol. 4928. pp. 335–346. Springer (2007).
7. Van der Aalst, W.M.P.: *Process Mining*. Springer (2011).
8. Ghodsypour, S.H., O'Brien, C.: *A decision support system for supplier selection using an integrated analytic hierarchy process and linear programming*. *Int. J. Prod. Econ.* 56-57, 199–212 (1998).
9. Shim, J.P., Warkentin, M., Courtney, J.F., Power, D.J., Sharda, R., Carlsson, C.: *Past, present, and future of decision support technology*. *Decis. Support Syst.* 33, 111–126 (2002).
10. Rozinat, A., Wynn, M., van der Aalst, W.M.P., ter Hofstede, A.H., Fidge, C.J.: *Workflow simulation for operational decision support*. *Data Knowl. Eng.* 68, 834–850 (2009).
11. Hollingsworth, D.: *The Workflow Reference Model*. (1995).
12. Krogstie, J.: *Perspectives to process modeling - A historical overview*. *Enterprise, Business-Process and Information Systems Modeling. LNBIP*, vol. 113. pp. 315–330. Springer (2012).
13. Barba, I., Weber, B., Del Valle, C., Jiménez-Ramírez, A.: *User recommendations for the optimized execution of business processes*. *Data Knowl. Eng.* 86, 61–84 (2013).

14. Barba, I., Del Valle, C.: Automatic generation of optimized business process models from constraint-based specification. *Int. J. Coop. Inf. Syst.* 22, (2013).
15. Hollingsworth, D.: The Workflow Reference Model: 10 Years On. *The Workflow Handbook*. pp. 295–312. Workflow Management Coalition (2004).
16. Van der Aalst, W.M.P., Pesic, M., Schonenberg, H.: Declarative workflows: Balancing between flexibility and support. *Comput. Sci. - Res. Dev.* 23, 99–113 (2009).
17. Jiménez-Ramírez, A., Barba, I.: Generating multi-objective optimized business process enactment plans. *Advanced Information Systems Engineering. LNCS*, vol. 7908. pp. 99–115. Springer (2013).
18. Schonenberg, H., Weber, B.: Supporting flexible processes through recommendations based on history. *BPM. LNCS*, vol. 5240. pp. 51–66. Springer (2008).
19. Hevner, A.R., March, S.T., Park, J., Ram, S.: Design science in Information Systems research. *MIS Q.* 28, 75–105 (2004).
20. Peffers, K., Tuunanen, T., Rothenberger, M.A., Chatterjee, S.: A Design Science Research Methodology for Information Systems Research. *J. Manag. Inf. Syst.* 24, 45–77 (2007).
21. Wieringa, R.J.: Design science as nested problem solving. *Proceedings of the 4th International Conference on Design Science Research in Information Systems and Technology - DESRIST '09*. pp. 1–12. ACM Press, New York (2009).
22. Wieringa, R.J., Heerkens, J.M.G.: The methodological soundness of requirements engineering papers: a conceptual framework and two case studies. *Requir. Eng.* 11, 295–307 (2006).
23. Prescher, J., Ciccio, C. Di, Mendling, J.: From Declarative Processes to Imperative Models. *Proceedings of the 4th International Symposium on Data-driven Process Discovery and Analysis, Milan, Italy*. pp. 162–173 (2014).
24. Bohmer, R.M.J.: *Designing care - Aligning the nature and management of health care*. Boston: Harvard Business Press (2009).
25. Pesic, M.: *Constraint-based workflow management systems: shifting control to users*, (2008).
26. Barba, I., Del Valle, C.: Filtering rules for ConDec templates - Pseudocode and complexity, <http://www.lsi.us.es/quivir/irene/FilteringRulesforConDecTemplates.pdf>, Accessed on 9 October 2014.
27. Mertens, S., Gailly, F., Poels, G.: Enhancing declarative process models with DMN decision logic. *Enterprise, Business-Process, and Information Systems Modelling. LNBIP*, vol. 214. Springer (2015).
28. OMG: Decision Model and Notation (DMN), [www.omg.org/spec/DMN/Current/](http://www.omg.org/spec/DMN/Current/), Accessed on 10 November 2014.
29. Mertens, S., Gailly, F., Poels, G.: Generating business process recommendations with a population based meta-heuristic. *BPM Workshops. LNBIP*, vol. 202. pp. 516–528. Springer (2014).

# Tactical Management In Focus: Adaptability and Information Systems

Renata Petrevska Nechkoska<sup>1,2</sup>

<sup>1</sup>UGent, Gent Belgium

<sup>2</sup>UKLO, Bitola, Macedonia

renata.petrevskanechkoska@ugent.be

**Abstract.** Tactical Management is an area where businesses can pursue competitive advantage. Lately, it has been under-addressed and even ingested by operational and strategic trends in Management and Information Systems. It needs adaptability as managerial way of thinking and acting along with proper information requirements recognition, in order for the person performing the tactical management function to accomplish best possible outcomes. With our research we are aiming to provide support in increasing the adaptability to changes for tactical management. At the same time, we are mapping the tactical management information system needs, to prove that they are distinctive from strategic, operational and project management information needs and should be addressed accordingly.

**Keywords:** tactical management, information systems, adaptability, sense and respond, requirements engineering

## 1 Introduction to the Context of the Problem Domain

The goal of the research is to delineate Tactical Management as a managerial function in order to provide comprehensive insight of its Adaptability and Information System needs. The foundation of the problem domain is in the setting that the person performing the function of tactical management is expected to manage a Complex Adaptive System, and steer it towards a purpose, continuously facing limitations and changes in the resources and environment. Furthermore, there needs to be compliance with the organizational context, as well as ongoing capture of the environmental everyday developments that influence the achievement of an outcome. The research is aiming to result with an artifact as a method for the person in the shoes of a tactical manager that embodies principles, guidelines and prescriptions on how to achieve adaptability for the tactical management function and proper information system self-design. We are addressing the following research questions: (1) what are the Tactical Management adaptability needs; (2) which are the Tactical Management Information Systems requirements and (3) how to design a method that addresses those needs.

Our initial constituent in the research problem are changes. Initially, we are making a distinction between adaptable and adaptive systems. A system or entity is **adaptable** if it can be adapted to changes by someone else. This means that someone (for exam-

ple, the manager) can be put in position to: design, steer and adapt the system towards a purpose. On the other hand, a system or entity is **adaptive** when it is able to modify itself in order to adapt to changes. This is a subtle but paramount difference. We perceive the company, the team, departments being managed as **Complex Adaptive Systems (CAS)**. CAS is defined as “A system of individual agents, who have the freedom to act in ways that are not always totally predictable, and whose actions are interconnected such that one agent's action changes the context for other agents” such as departments, organizations, ... [17]. The CAS is adaptive by itself. Also the entities it is consisted of are adaptive – in our case the people, or groups of people [1].

If we incline on some rules of balancing complexity on the ‘Edge of chaos’, we should not be addressing complex subjects with complex solutions. The ‘edge’ needs both structure and freedom. The addressing of a complex system needs: (1) Simple rules; (2) Moderately dense connections; (3) Human rules on: how to detect information, how to interpret information and how to act in response [20]. Hence, when facilitating and managing CAS towards a purpose, one should be introducing rules, connections, information detection and interpretation, and response guidelines; not complex or even complicated rigid solutions that, by definition, detain adaptability, rather than integrate it. Furthermore, when performing the tactical management function, the manager needs instructions on how to act, think and behave appropriately in order to facilitate a **socio-technical system** to continuously fulfill its purpose, for as long as required, in changing contexts, by **continuous context capture**.

We are proposing that for tactical management one needs to think in terms of ‘**system design**’, **not process flow**. The system a tactical manager sets up should be **adaptable** – one should be able to make modifications to it, so that consequently it adapts to changes. This would be the articulated purposeful adaptable mechanism that should give a framework for the manager to steer and for the CAS to follow. The Tactical Management Information System should capture and assist this behavior appropriately. The research problem is investigated more elaborately in section 3.1.

## 2 Current Status of the Tactical Management Adaptability and Information Systems

There is almost clear distinction between the ‘efficiency-centric’ and ‘adaptive’ managerial paradigms, in this post-industrial, knowledge-centric era. On one hand, the “make-and-sell” proponents are prescribing planning, efficiency and business processes; command-and-control management approach; matrix organizations. On the other hand, there is the “sense-and-respond” paradigm, where the unpredictability is expected and further on integrated in the way of working and structuring of the organization. [7] Across this polarization is the project management model, where dynamic and to a certain extent flexible systems and relations are formed regardless of the organization’s current setting.

Our definition for tactical management as a managerial function is: ***How to achieve what is expected by utilizing what is given and following certain governing principles in the current context of the organization and environment.*** Through these identified constituents for tactical management, we searched for existing state-of-the-art concepts and support, in order to address a gap with unique viewpoint and provision.

Tactical Management Information Systems (TMIS) should be able to provide, record and revise in an adaptable manner, information for the continuous changes occurring in the behavior of the socio-technical system and its environment.

Issue 1: In our investigation, the Tactical Management Information Systems and Managerial Methods are somewhat **omitting** [16] and/or **under-addressing** the specificities of tactical management. Tactical management differs from operational, strategic and project management, in a number of characteristics, as it also has similarities with all of them. Hence, it should be recognized properly, in order to engineer the Information System requirements accordingly. Otherwise, the current situation will persist – information system designs, models and artifacts blend-in tactical management either to strategic or operational management – with regular reports, prevailing quantitative data, not very flexible custom combinations or ‘runtime’ changes to requests [16]. The approaches addressing information systems in general, and aligning them with the business needs, or providing assistance for the managers in organizations are diverse starting from Enterprise Ontologies, Enterprise Architectures, Business Modeling, Business Process Modeling – extended in the works such as Component Business Model, Business Motivation Model, Service Oriented Architecture, Business Intelligence Model (BIM) and i\* [2][14], Business Event Processing, all the way to Business Activity Monitoring, Process Mining, Information Quality Improvement [16]. We try to enforce capture of the **multi-faceted aspects of context** (the device, the user, the task, the document source, the document representation, spatio-temporal dimensions: time, frequency and geographic location) to prove the exact information system needs.

Issue 2: With regards to the **necessity for adaptability, of the person** dealing with tactical management, and **of the system** that person is managing, we are emphasizing several components that introduce constantly changing environment and degree of unpredictability. We identify two kinds of ‘context’ that tactical management needs to take in consideration – **organizational context** and **environmental context**, where changes occur, especially for tactical management. The different approaches in literature perceive enterprise-wide or business process adaptability [2] [3] [10] [11] [12] and fewer offer artifacts for managerial adaptability as persons [4] [6] [12]

Issue 3: **The Person** dealing with TM is not supported with appropriate artifacts (investigation elaborated in section 3.1). Current artifacts offer organizational view, or if aimed for the manager (senior, project, operational) they don’t involve tactical issues to substantial extent (Strategic management – Balanced ScoreCard, Triple Bottom Line, The Performance Prism; Project management – PMBOK, Product Lifecycle; Operational management – Agile, Scrum, Lean)

### 3 Design Science Research

Design Science Research is gaining importance in current Information Systems research [5]. It enables the researchers, by going through the Relevance Cycle (Requirements, Field testing), the Design Cycle and the Rigor Cycle (Grounding, Additions to Knowledge Base) [8] to carry on scientifically acceptable and real-life implementable designs that reduce the time to improve the world with our contributions, especially since the artifacts are designed with assistance of current real-life entities.

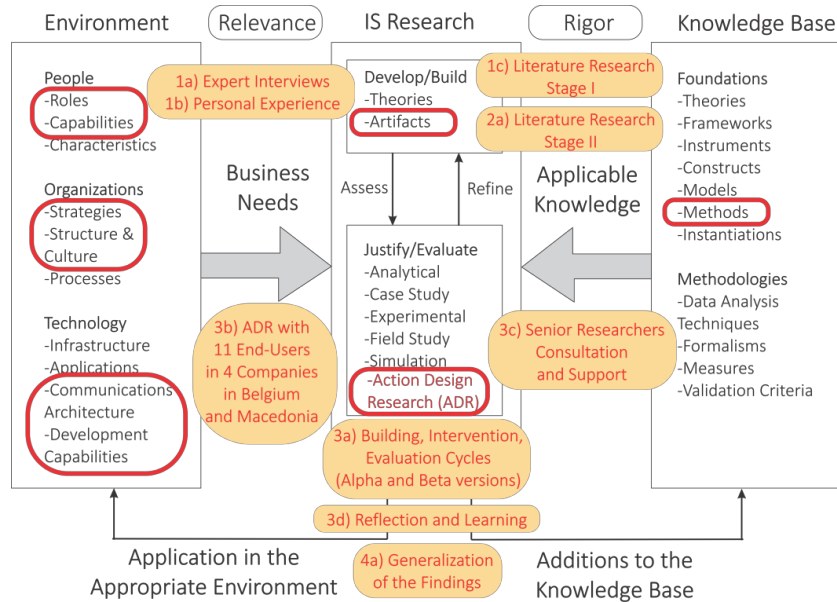

**Fig. 1.** Tactical Management Research as Design Science Research [9]

### 3.1 Phase 1 – Identifying Tactical Management Adaptability Needs and Information System Requirements

During the course of the research, the main focus of the initial stage of the investigation was recognizing a problem. We started the research by conducting semi-structured interviews with 30 managers on various levels (Senior, Middle, Project managers, SME Owners) from, mostly international companies, but also SMEs situated in Belgium and in Macedonia, with geographic scope of work nationally and internationally. This activity supported the more accurate positioning of the problem; and provided us with expert opinions on various practices (Fig.1, labels 1a, 1b). Also, we investigated current State-of-the-Art contributions in literature, for tactical management adaptability and information systems (Fig.1, label 1c).

By interviewing managers in companies, we identified existence of lack of appropriate support with reports, information flows and ability to obtain them per request; treatment of the tactical management needs with approach identical as either operational management (with big data and no latency) or strategic management (with KPIs and quarterly reports, somewhat too late or inadequate) etc. The most frequent answer from the managers, on how they are addressing the issue of handling the mismatch between what is needed and what is provided, was by extracting the relevant data from reports in ERP systems and manually shaping it in Excel or by hand. This way they had been able to reach the needed information scope, structure, depth, manner of obtaining, and updating cycles. Furthermore, tactical management denotes ongoing and ‘runtime’ [19] [22] adjustments and changes in the people, systems, resources, expectations, processes that influence the outcome of any managed activity. Literature

review for supportive contributions to the problem of tactical management adaptability and information systems has been performed as described in section 2 of the paper.

### **3.2 Phase 2 – Investigating Literature for Grounding Reasons**

After being supported with practitioner real-life problems that confirmed our initial standpoint, expert opinions of different practices regarding tactical management, we consulted literature for proper academic ground for design (Label 2a on Fig.1)

Currently, the approaches investigated in literature, provide adaptability as adjustment, predefinition, corporate agility, or response modeling [10] [11] [21] in terms of business processes and enterprise-wide business process re-engineering and adaptation [12]; goal oriented requirements engineering and relating requirements to organizational and business context [13] as well as prescriptions of modularity and adaptability prescribed in the Structure of the company [3] [2]; model-driven capability for continued focus on responsiveness and adaptability [12], or modeling and reasoning of strategic business plans involving tactical level [4], while the system design and the Sense-Interpret-Decide-Act loop are incorporated in the work of [6]

We used the Sense-and-Respond framework as foundation for the research contribution in TM. It provides (1) System Design and (2) Sense-Interpret-Decide-Act Loop for continuous discovering of early signals, reasoning upon them, and introducing changes and reconfiguration to the system accordingly. The main elements of the framework are purpose, strategy, structure, governance, which we are attempting to shape for the use of tactical management. The system is designed of roles and accountabilities, towards a purpose. Strategy is the “modular system design of roles and accountabilities” and in S&R organizations “structure is strategy”. The governance “is the systematic propagation and assurance of global policy constraints to all roles in the organization”. [6]

The foundations of the design throughout the research have been encompassing existing theoretical frameworks and concepts in: Information Systems, Management (Strategic management, Leadership, Operational management), Knowledge Management, Complexity theory, Complex Adaptive Systems, Behavioral science, Systems theory, Network theory with Social Network Analysis, Social Systems Design, as well as Research Methodology, Design Science Research, Action Design Research and Behavioral Research.

### **3.3 Phase 3 – Action Design Research as Research Method**

The Design cycle took place in constant communication with Practitioners and Academics (Fig. 1, Labels 3a, 3b, 3c, 3d). We collaborated with 4 Companies for the Action Design Research (ADR) [18]: Company 1, small software implementations and consultancy – the Owner/manager of the company has been our End-user 1; Company 2, big consultancy with Headquarters in Belgium – a senior manager and 9 Project Managers and Team Leads have been our End-users 1-9; Company 3, small geodesic and engineering bureau – the Owner/manager of the company is our End-

user 10; Company 4, big production company with Headquarters in Macedonia – the Director of development department is End-user 11.

In the 4 organizational contexts-companies, the artifact design has been going through Alpha-version – in Company 2 (Belgium) and Company 3(Macedonia) we have investigated a tactical management issue – and proposed a Sense-and-Respond solution for the management to follow; Company 2(Belgium) – Optimizing staff utilization across projects (Microsoft Dynamic Implementations and Consultancy) and Company 3 (Macedonia) Shifting the Customer Perception for the Company (from only geodesic services to engineering, geodesic and consultancy services). The Beta-version took place in Company 1(Belgium) and Company 4(Macedonia) where we have investigated a tactical management issue – proposed S&R solution for the management to follow – and one manager in the companies carried on the usage of the design throughout next months to register all the information needs (Information Sensors, Emitters, Risks), changes as well as all system re-design needs – in Company 1(Belgium) – Enable customer’s management to spend least time possible on remote communication with geographically scattered staff members; in Company 4(Macedonia) – Provide earliest information for status and discrepancies to management in a new factory construction and equipment alignment project.

To properly position a tactical management issue in the companies, we performed in-depth analysis of the company, business, mission, vision, goals, strategy, current systems, tactical management approach, expectations and SWOT analysis by conducting interviews, panel discussions with the End-users and cross-discussions with the management. We tried to point out the usefulness of the ADR in their company both for the researchers and for the company utilized their expert opinion and constructive criticism which was valuable for the outcome. After start, we trained the End-users with the primitive concepts and roadmap of the S&R framework.

We will argue that our Action Design Research has enabled us, throughout the timeline of 14 months of work with the End-Users, to go through advancing the Alpha- and Beta- versions of the design. We approached each manager and company with the same initially designed version of the initial artifact (in Excel Workbook of 4 sheets) which they filled and individually revised by performing the SIDA loop, but we informed each newly involved manager with the benefits of the use from the previous ones. It is certain to say that the ‘learning’ on the side of the researchers, has been communicated with the End-Users back and forth.

**Our Design and Results so far.** The artifact-in-construction (a method for the manager- the person) we tested with practitioners in the ADR has been consisted of the following investigation of adaptability and information system self-design:

1. Designing a **System**, according the Sense-and-Respond Framework principles (Visualizing and Specifying Purpose, Governing Principles, Role and Accountability, Conditions of Satisfaction)
2. Designing **Information Sensors** – what the manager would need to have as information to have overview of his system (Visualization, Attributes and Indicators)
3. Designing the **Information Emitters** – what the tactical manager would like to have been told by the other roles in order to be aware on time for possible issues disturbing the agreed outcomes (Visualization, Attributes and Indicators)



#### 4. Designing the **Risk Management** (Visualization, Attributes and Indicators)

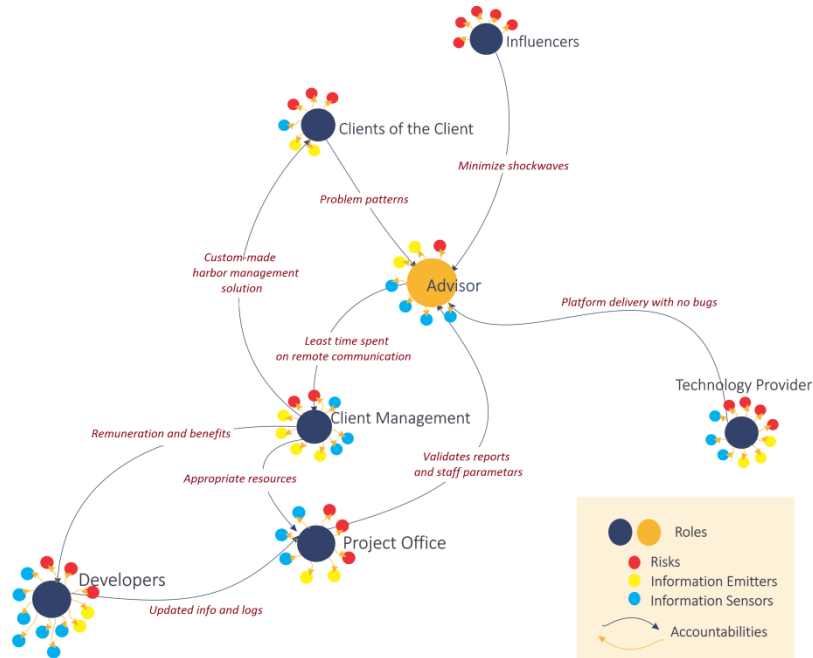

**Fig. 2.** Tactical Management Adaptability and Information System Needs Snapshot with Bipartite graph using Social Network Analysis, in a Role-and-Accountability Diagram, for the Role of ‘Advisor’

In the Sense-and-Respond framework, we identified 3 adaptability components:

- Adaptability component 1 - The Re-negotiations for outcomes, every role can perform through conditions of satisfaction, in order to adapt to changes.
- Adaptability component 2 – Introducing and terminating roles and accountabilities.
- Adaptability component 3 – Populating roles according human resources/systems.

We consider the Sense-Interpret-Decide-Act loop as perpetual engine to adaptability, which enables the system designer (manager) to continuously scan the organizational and environmental context for changes, and receive early warning signals, on the entities previously incorporated in the widest system of Roles and Accountabilities. This opens the radars (Information Sensors, Emitters and Risks) and initiates information flows with variable content, frequency, type, manner of obtaining etc. The SIDA loop helps the managers reduce unexpected events and self-design the information system needs, on an ongoing basis, and identify whether some activity or information flow needed to be more efficient or automatized.

To present at least one of the resulting visualizations that present the system design and the tactical management information system, we are using the Social Network Analysis (SNA) tool – bipartite graph with nodes (for roles and information needs) and edges (for accountabilities). The two types of entities used in the graph are Roles

and Information Sensors, Emitters, Risks. Of course, such a static view (Fig. 2) for something so alive and changing, such as the Complex Adaptive Systems on one side, and our Sense-and-Respond system on the other, is not enough. But when presented on a timeline – using SNA timeline feature – the alive, adaptable, adaptive and flexible nature of tactical management and its information system needs comes before our eye-view.

### 3.4 Conclusion and Perceived Contributions

By conceptually positioning a manager to design and maintain a **Sense-and-Respond** system that is **adaptable** to the changes and unpredictability in order to manage a **Complex Adaptive System** towards a **purpose**, we are aiming to assist the manager in fulfilling this task successfully. Our focus on tactical management is purposeful because it has been under-addressed and to some extent inappropriately addressed [16]. Our selection of **Social Network Analysis** – graphs that visualize the network of roles (nodes), and the accountabilities (edges) has proven useful for the practitioners and theorists in the perception of the system, its reconfigurations, communications, information and risk sensors. When a timeline is used, the graphs become the most proximal representation of the system's adaptability and accurate designer of the tactical management needs for Information Systems. Our selection of **Action Design Research** and placing it in **Design Science Research Methodology** has been spontaneously driven by the motive to produce artifact that is immediately functional in at least one real environment; and to simultaneously involve design stakeholders from all aspects: practitioners, end-users, researchers, academics. We believe that tactical management information system needs have not been mapped to such depth and structure; the context capture (both organizational and environmental) and the proposed system design approach to becoming more adaptable while managing Complex Adaptive Systems represent distinctive traits of our research, as multi-, inter- and trans-disciplinary contemplation for both science and practice. The resulting artifact, as method, for the manager (the person) performing the tactical management function, delivers principles, guidelines and prescriptions that are expected to improve tactical management adaptability and map the tactical management information system distinctive requirements.

**Acknowledgements.** This research has been under valuable mentoring of Prof. Dr. Geert Poels, UGent, Gent, Belgium and Prof. Dr. Gjorgji Manceski, UKLO, Bitola, Macedonia as a Double PhD Degree pursuit.

### References

1. Ackoff, R.:Towards a System of Systems Concepts, Management Science, USA (1971)
2. Barone D., Mylopoulos J., Jiang L., Amyot D.:The Business Intelligence Model: Strategic Modelling, University of Toronto, Canada (2010)
3. Casadesus-Masanell R., Ricart J. E.:From Strategy to Business Models and to Tactics, IESE Business School, University of Navarra (2009)

4. Francesconi, F., Dalpiaz, F., Mylopoulos, J.:TBIM: A language for modeling and reasoning about business plans, DISI, Italy (2013)
5. Goes, P.:Design Science Research in Top Information Systems Journals, MISQ, (March 2014)
6. Haeckel, S.:Adaptive Enterprise: Creating and Leading Sense-And-Respond Organizations, Harvard Business School Press Boston (1999)
7. Haeckel, S.:Peripheral Vision: Sensing and Acting on Weak Signals Making Meaning out of Apparent Noise: The Need for a New Managerial Framework, Long Range Planning, Elsevier (2004)
8. Hevner, A.:Three Cycle View of Design Science Research, Scandinavian Journal of Information Systems (2007)
9. Hevner, A., March, S.,Park, J., Sudha, R.:Design Science in Information Systems Research, MISQ (March 2004)
10. Iafra F.:Use Case: Business Intelligence “New Generation” for a “Zero Latency” Organization (When Decisional and Operational BI are Fully Embedded), Digital Enterprise Design and Management, Springer Berlin Heidelberg (2013)
11. IBM:Empowering the business to sense and respond: Delivering Business Event Processing with IBM WebSphere Business Events, Business Event Processing, WebSphere software White Paper, IBM New York (2008)
12. Kapoor S., Bhattacharya K., Buckley S., Chowdhary P., Ettl M, Katiricioglu K., Mauch E., Phillips L.:A technical framework for sense-and-respond business management, IBM Systems Journal, Vol 44 (2005)
13. Mylopoulos, J.:Goal oriented requirements engineering, CibSE (2008)
14. Nalchigar S., Yu E.:From Business Intelligence Insights to Actions: A Methodology for closing the Sense-and-Respond Loop in the Adaptive Enterprise, The Practice of Enterprise Modeling, Springer Berlin Heidelberg (2013)
15. Petrevska Nechkoska, R., Manceschi, G., Poels, G.:Meeting Point of Strategy and Operations: Tactical Management Sense-and-Respond Framework Enhancement, Proceedings of the 8th ECIME 2014, AC&PI Ltd., UK (2014)
16. Petrevska Nechkoska, R., Poels, G. Manceschi, G.:From Strategy to Operations and Vice-versa: a Bridge that Needs an Island, Proceedings of the 8th ECIME 2014, AC&PI Ltd., UK (2014)
17. Plsek, P. E.: Working Paper: Some Emerging Principles for Managers of Complex Adaptive Systems (CAS), Accessed March 2015,
18. Sein, M. K., Henfridsson, O., Purao, S., Rossi, M., Lindgren, R.: Action Design Research, MISQ (March 2011)
19. Zdravkovic, J., Stirna, J., Henkel, M., Grabis, J.: Modeling Business Capabilities and Context Dependent Delivery by Cloud Services, CAISE 2013, LNCS 7908, Springer-Verlag Berlin Heidelberg (2013)
20. Waldrop, M. M.: Complexity: the emerging science at the edge of order and chaos, Simon & Schuster, New York (1992)
21. Werner S.,:Sense and Respond Business Performance Management, Supply Chain Management on Demand: Strategies, Technologies, Applications, Springer Berlin Heidelberg (2005)
22. Berzisa S., Bravos G., Gonzales T. C., Czubayko U., Espana S., Grabis J., Henkel M., Jokste L., Kampars J., Koc H., Kuhr J-C., Llorca C., Loucopoulos P., Pascual R. J., Pastor O., Sandkuhl O., Sandkuhl K., Simic H., Valverde F. G., Zdravkovic J.: Capability Driven Development: An Approach to Designing Digital Enterprises, Springer Fachmedien Wiesbaden (2015)

# Situational Method Engineering in ERP implementation methodologies

Adnan Kraljić<sup>1</sup>

<sup>1</sup> Ghent University, 9000 Ghent, Belgium

[adnan.kraljic@ugent.be](mailto:adnan.kraljic@ugent.be)

PhD Supervisor: prof. Geert Poels, Ghent University

PhD Co-Supervisor: prof. Jan Devos, Ghent University

**Abstract.** Enterprise Resource Planning (ERP) implementation is a complex and active process, one that involves a mixture of technological and organizational interactions. Often it is the largest IT project that an organization has ever launched and requires a mutual fit of system and organization. Concept of an ERP implementation supporting business processes across different departments in organization is not a generic, rigid and uniform process - it is a vivid one and depends on number of different factors. As a result, the issues addressing the ERP implementation process have been one of the major concerns in industry. Therefore ERP implementation process receives profound attention from practitioners and scholars in its academic or industry papers. However, research on ERP systems so far has been mainly focused on diffusion, use and impact issues. Less attention has been given to the methods/methodologies used during the configuration and the implementation of ERP systems; even though they are commonly used in practice, they still remain largely unexplored and undocumented in Information Systems research domain. This paper is useful to researchers who are interested in ERP implementation methodologies and frameworks. We will briefly reference current main stream developing's in academia and industry regarding ERP implementation methodologies and frameworks and discuss it through ideas and concepts developed in Situational Method Engineering's current practices. At the end, this paper also aims at the professional ERP community involved in the process of ERP implementation by promoting a better understanding of ERP implementation methodologies implementation methodologies in general and frameworks, its variety and future development.

## 1 Introduction

Implementing an ERP system is a major project demanding a significant level of resources, commitment and adjustments throughout the organization. Often the ERP implementation project is the single biggest project that an organization has ever launched [1]. As a result, the issues surrounding the implementation process have been one of the major concerns in industry. And it further worsens because of numerous failed cases include a few fatal disasters which lead to the end of some companies.

In previous studies can be found that almost 70% of ERP implementations fail to achieve their estimated benefits [2]. Although ERP can provide many benefits for organization, goals are often changed to getting the system operational instead of realizing the goals [3]. Reflecting such a level of importance, the largest number of articles in literature belongs to this theme. It comprises more than 40% of the entire articles [4]. Many of these articles share implementation experiences from various companies. Also, various models of implementation stages and different implementation methodologies are presented and will be discussed more in the next section.

## **2 ERP Implementation Methodologies In General**

ERP implementation methodologies have similar factors with software development life cycle or framework on developing software. However, the main difference is, in the ERP implementation methodology, we do not talk about how to develop ERP system. We are mainly discussing how to adopt ERP system with the organization [5]. Perhaps the biggest distinction between ERP systems and “traditional systems” is the way they are developed and implemented. Simplified, the traditional way means that the company hires a consulting company, a requirement specification is developed and then the system is developed according to that specification as well as the organizations business processes. Either from an open template or from scratch, all parts are customized to fit the particular business. On the other hand, an ERP is a packaged software application that is bought “off the shelf” [6]. It consists of modules for different business functions such as finance, HRM, accounting and Inventory Management. Instead of the system being created with respect to what the business processes looks like, an ERP is developed independently and it’s up to the organization to adapt to the ERP. However, it’s not “plug and play” software and do generally require some degree of customization in order for the organization to enjoy full benefits. Due to these issues, some research has been conducted on creating frameworks for reaching success when implementing an ERP system [7]. ERP implementations are modeled in order to structure such a large entity into pieces capable of being controlled, i.e. stages or phases. A similar approach has been used in modeling e.g. software engineering projects. The phases can then be described by the objectives, activities, and stakeholders involved. Several models of ERP implementation methodologies are provided in literature (and in practice) and they vary according to e.g. the number of phases.

The phases in ERP implementation frameworks are often counted as between three and six [8]. Within the method engineering research discipline it has been recognized that there is no “one-size-fits-all” method for a problem domain. Instead, so called situational methods which are adaptable to a specific problem situation need to be developed. Regarding the fact that the implementation/rollout of an ERP solution is a complex problem as it is an integrated approach that is related to organizational and IT aspects, the need for a comprehensive methodological support for the implementation of ERP solutions, described in academic literature, becomes obvious. Situation Method Engineering seeks for utility by developing innovative artifacts. [9] Such

artifacts can be in the form of constructs, models, methods, or instantiations. Based on the all information provided in previous paragraphs the following research question arises: *How could the ERP implementation methodologies/frameworks be supported systematically; where the type of the implementation project, stakeholders of ERP projects and the specifics of the ERP solution (domain) are taken into consideration?* In other words, could the ERP implementation methodologies benefit from the use of Situational Method Engineering concepts? In next chapters we will try to provide landscape which we need in order to find answers for this research question.

### **3 ERP implementation: Activity is what matters**

Nowadays, number of ERP methodologies are described in academic and professional IS domain. Common for both domains (professional and academic) is that they strive to describe ERP implementation methodologies as sequence of activities required for ERP implementation process. In these methodologies (academic and professional), all relevant (as author perceive relevant) activities are described and defined in terms of goals, results and necessary resources. Several authors provide research that is based on the assumption that a range of activities exists which represents the most relevant activities in an ERP implementation project. Although several authors showed the phases in an ERP project (and activities in these phases), a complete list of all relevant activities in an ERP implementation project was not found, unfortunately. Several authors pointed out activities which where relevant according to their point of view in their papers, but none of them intended to collect all possible relevant activities [10].

By examining papers with different views the authors expect to have found the most relevant activities. Guy Janssens<sup>1</sup>, Rob Kusters<sup>1</sup> and Fred Heemstra tried to lay a foundation for defining the size of an ERP project. They organized activities in clusters which contribute to the same intermediary product or products. For instance, an intermediary product such as ‘trained users’ can be achieved by a cluster of activities such as: ‘prepare training material’, ‘train the trainers’, ‘set up training infrastructure’, ‘train users’ etcetera. [10] A literature search was performed aiming at finding papers in which activities within an ERP implementation project were listed. From these papers a collection of names and expressions of activities was retrieved. The papers were retrieved from a collection of about 200 papers which were composed of papers selected from ‘A Comprehensive ERP bibliography - 2000-2004’. Next table shows the list of clusters and sub clusters of activities and the classification into the three categories (Group view). [11]

**Table 1.** Clusters, Sub-clusters and Group View (fragment)

Clusters	Subclusters	Group view			Number of unique activities
		Project	System	Organization	
Selection	Vendor selection		✓		4
	Product selection		✓		16
Project configuration		✓			19
Project management	Management	✓			4
	Communication to organization	✓			4
Organizational and system design	Current state analysis			✓	5
	Organizational requirements			✓	7
	Requirements ERP system		✓	✓	8
	High level Design		✓	✓	6

#### 4 ERP Implementation Methodologies in Literature

Research on ERP systems has so far been mainly focused on implementation CRF/CSF and impact issues. Less attention has been given to the methods used during the configuration and the implementation of ERP systems, even though they are commonly used in practice they remain unexplored in ISD research. Several models of ERP implementation methodologies are provided in literature and they vary according to e.g. the number of phases. The phases in ERP implementation frameworks are often counted as between three and six, according to Somers and Nelson [12]. However, the Umble model [13] includes 11 phases and it gives practical checklist-type guidance for an ERP implementation. On the other hand, the models of Markus and Tanis, for example, or Parr and Shanks are very general, and are merely used for analyzing ERP implementation projects. The models are useful in studying, analyzing and planning ERP implementation.

The selection of ERP implementation method mentioned in paper is based on the degree of “institutionalization” in the scientific community. Livari and Hirschheim described six criteria to determine institutionalization: including 1) the existence of scientific journals, 2) scientific conferences, 3) textbooks, 4) professional associations, 5) informational and formal communication networks, and 6) citations. There are number of different ERP implementation methodologies mentioned and described in literature. However, there is an issue with methodology scope, context and its ambiguity. For example, some methodologies treat the phases before the acquisition of an ERP system (and are focused on it), while some methodologies put stress on phases after the ERP system has started to be used (production phase). Different authors

provide different sequence of phases and diverse naming practice. The preliminary phases are, for example, initiation and requirements definition defined by Kuruppuarachchi, project chartering by Markus and initiative and selection by Makipaa. [14] It is obvious that there is no ground based ERP implementation methodology, widely accepted and tested. Even though they are commonly used in practice (ERP implementation methodologies) they still remain largely unexplored and undocumented in Information Systems research domain. Next table summarize list of proposed implementation methodologies followed by the degree of institutionalization in scientific community.

**Table 2.** ERP implementation models and Author(s)

<b>Author(s)</b>	<b>ERP implementation model</b>
Bancroft et al. (1998)	(1)Focus, (2)Creating As – Is picture, (3) Creating of the To-Be design, (4) Construction and testing and (5) Actual Implementation
Kuruppuarachchi et al. (2000)	(1) Initiation, (2) Requirement definition, (3) Acquisition/development, (4) Implementation, and (5) Termination
Markus and Tanis (2000)	(1) Project chartering, (2) The project, (3) Shakedown, and (4) Onward and upward
Makipaa (2003)	(1) Initiative, (2) Evaluation, (3) Selection, (4)Modification, Business process Reengineering, and Conversion of Data, (5) Training, (6) Go – Live, (7) Termination, and (8) Exploitation and Development
Parr and Shanks (2000a)	(1) Planning, (2)Project: a. setup, b. reengineer, c. design, d. configuration and testing, e. installation (3) Enhancement
Ross (1999)	(1) Design, (2) Implementation, (3) Stabilization, (4) Continues improvement and (5) Transformation
Shields (2001)	Rapid implementation model of three phases and 12 major activates
Umble et al (2003)	(1) Review the pre-implementation process to date, (2) Install and test any new hardware, (3) Install the software and perform the computer room pilot, (4) Attend system training, (5) Train on the conference room pilot, (6) Established security and necessary permissions, (7) Ensure that all data bridges are sufficiently robust and the data are sufficiently accurate, (8) Document policies and procedures, (9) Bring the entire organization on – line, either in a total cutover or in a phased approach, (10) Celebrate, and (11) Improve continually
Verviel and Halingten	(1) Planning, (2) Information search, (3) Selection, (4) Evaluations, and (5) Negotiation



#### 4.1 ERP Implementation Methodologies in Practice: Example of ASAP 8

Because of the high number of failed ERP implementation projects, ERP vendors have developed their own methodologies that best fit their packages. The selection of ERP implementation method (chosen to be described in this paper) is based on the degree of institutionalization in the scientific community. ASAP is one of the few ERP implementations methods addressed by the research community [15]. In addition, there are professional associations promoting ASAP and there are newsgroups on the Internet representing informal networks and are cited in case studies, such as Geneva [16]. Furthermore, ASAP is well established on the market as regards implementing a market leading ERP system and it is used in education via the university alliance program between SAP and about 400 universities around the world. Thus, the method has both practical and educational relevance and meets several of Kuhn’s institutional assessment criteria. The success of SAP implementation is to a large degree determined by the speed and the effectiveness of the software to add value to your organization. That is why SAP has introduced Agile ASAP; a new, practical implementation methodology that allows you to implement operating functionality in short iterative cycles. In each cycle the team implements the most valuable and important functionality first. This enables you to generate results faster, gain immediate insight into the value, increase the flexibility of the implementation and improve progress monitoring.

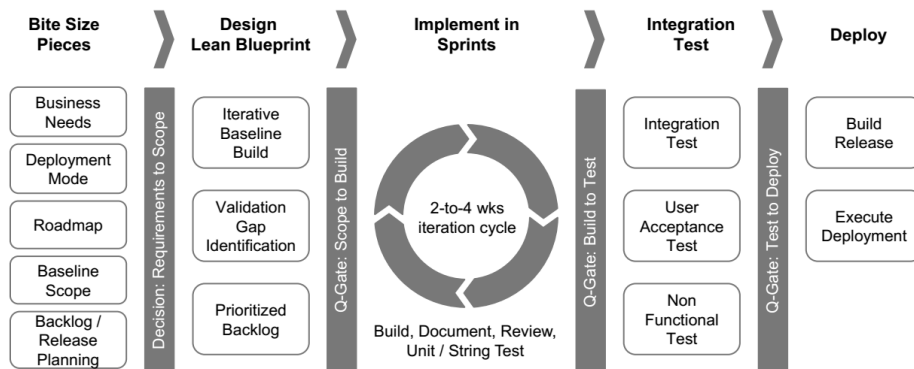
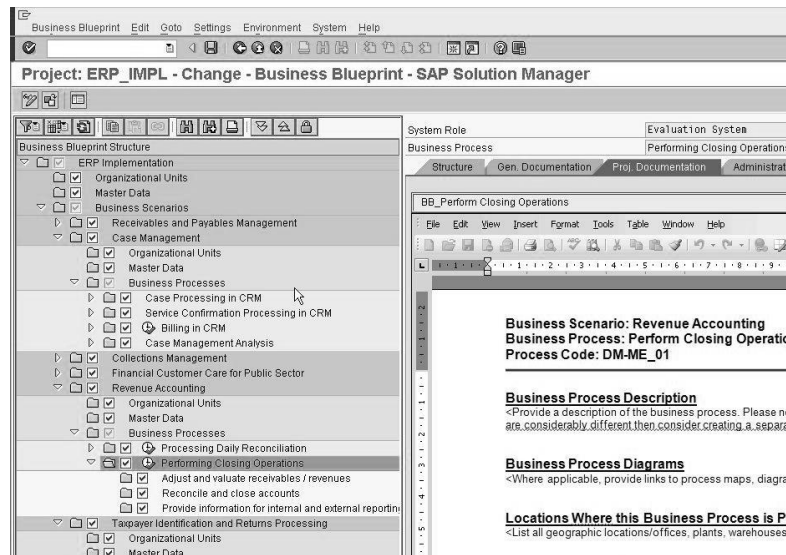

Fig. 1. Agile ASAP 8 Methodology Phases)

All phases in ASAP 8 are provided on SAP official website [www.sap.com](http://www.sap.com). It is important that each of these phases is developed in detail, down to its smallest bit – activity. Also, there are hundreds of different, industry specific, business scenarios and processes suggested as preconfigured ERP solution building blocks. Regarding the industry (situational factors), using the SAP product named “Solution Manager” you are able to build you process by connecting suggested activities and appropriate roles. Plan of this PhD research is to conduct comprehensive study of ASAP 8 as an industry leading ERP implementation methodology. Next Figures shows a SAP Solution Manager screenshot.

Fig. 2. Agile ASAP 8 Methodology Phases)



## 5 Situational Method Engineering in ERP Implementation

As several authors [17] have stated, the implementation process of an ERP system is best conceptualized as a business project rather than the installation of a new software technology. Unfortunately, comparing to ERP vendor's implementation methodologies (its comprehensive structure and context based approach) academic literature in this domain mostly stayed idle – not progressing in order to, in best possible way, describe what is going on in professional ERP implementation practice. Structured recommendations or methods supporting the implementation are completely missing. In addition, traditional approaches from software engineering that address the implementation of software in general cannot be applied “as is” to ERP solutions because they do not consider certain ERP specifics. As mentioned previously, the fact that the implementation/rollout of an ERP solution is a complex problem as it is an integrated approach that is related to organizational and IT aspects, the need for a comprehensive methodological support for the implementation of ERP solutions, described in academic literature, becomes obvious. Situation Method Engineering seeks for utility by developing innovative artifacts . Such artifacts can be in the form of constructs, models, methods, or instantiations [18]. Within the method engineering research discipline, but also in other areas of research it has been recognized that there is no “one-size-fits-all” method for a problem domain [19]. Instead so called situational methods which are adaptable to a specific problem situation need to be developed. Methods/methodologies are considered to be Design Science Research artifacts. They “describe viable ways of

performing goal-oriented activities in order to solve a real-world problem” [20]. Thus, situational methods should incorporate method configurations that allow for the user/role specific configuration of a situational method [21].

In the literature, different terms and understandings are used for the method building blocks that are the basis of situational method composition approaches (e.g. method fragment, method chunk or method component. Activities describe the main units of work whereas techniques support activities by giving detailed and precise instructions. Each method fragment is characterized by exactly one result that is created by one or more activities which are supported by one or more techniques. [22]. Identification of method fragments is one of the first steps of situational method composition. In order to increase their re-use, the identified method fragments are stored in a so called method base [23]. Thereafter, it is necessary to derive rules that allow for the composition of method fragments into situational methods in order to address the problem situation at hand. With the help of such rules, method fragments can be put in a temporal and logical order; they are also stored in the method base. Based on the identified situation and a method base, situational methods can be composed. Having on mind previous paragraph it is obvious that situational methods can be developed to address a specific problem situation. However, Mirbel and Ralyté [24] criticize that users of a situational method still have to “apprehend the method as a whole and understand all its concepts in order to use it, which can have some negative impact and discourage” the users from using the situational method. A user/role has to perform specific activities and thus needs his/her own configuration of the situational method [. To address this issue, Mirbel and Ralyté suggest combining situational method composition and situational method configuration. Each method construction approach starts with the aggregation of method fragments which implies that previously the situation has been characterized and the method base was filled with method fragments and corresponding rules. Thereafter, the obtained situational method can be configured for each user by only presenting those method fragments referring to his/her role and thus supporting his/her tasks [24]. This implies that roles and corresponding method configurations have been identified beforehand. Summing up, it should be noted that situational method engineering that meets the requirements of Mirbel and Ralyté (see above) is comprised of the following steps (Steps three and four could also be conducted in parallel):

1. Characterization of the situation
2. Identification of method fragments
3. Development of method configurations by assigning roles
4. Derivation of rules for the assembly of method fragments

ERP is implemented into the productive environment of a company (and it represents backbone of the modern transactional business operations). Discussion of related work in literature (academic) shows that there is no systematical support for supporting the implementation phase. That is why we would like to focus on the development of a situational method for the implementation of ERP system. Including the combined

method construction approach of Mirbel and Ralyté , we would firstly characterize the situation(s) in which the future situational ERP implementation method can be used. Next, we would derive method fragments that support the implementation of ERP solution. Thereafter, we would identify roles (types of users) that conduct portions of such a situational method. In addition, we would specify method configurations. They determine only those method fragments of the situational method that support the tasks of the different roles. Before identifying appropriate method fragments, the situation in which the fragments can be used has to be specified. We should assume that the use of a complex ERP solution depends on the size of a company, i.e. that such a solution will presumably more often be implemented in a large company than in a smaller one. Moreover, we assume that implementing such a ERP solution in a large company will require different support than implementing it in a smaller one. This is just one example of characterization of the situation in ERP implementation. In order to have a complete solution (described) it is needed to undertake execution of all steps that Mirabel and Ralyte suggested as part of developing situational method (in this case for ERP implementation method) [25].

## 6 Conclusion

ERP is the largest enterprise application software market with revenue projected to reach \$26.9 billion in 2015 projected by Gartner. However, as mentioned previously in this paper, studies show that almost 70% of ERP implementations fail to achieve their estimated benefits. In this paper, which is part of PhD thesis work, we provided brief literature review of ERP implementation methodologies and its phase in IS research field domain. It is obvious that there is no ground based ERP implementation methodology (described in literature), widely accepted and tested. Even though they are commonly used in practice (vendor's ERP implementation methodologies) they still remain largely unexplored and undocumented in Information Systems research domain. Also we have briefly described one of the most advanced ERP implementation methodology provided by SAP (biggest ERP vendor) named ASAP 8 (agile methodology) which is the method that has both, practical and educational, relevance and meets several of Kuhn's institutional assessment criteria. It is methodology tailored to meet specific need of organization such as size, industry, business process settings etc. There is no need to dig deeply, it can be seen that academic literature is not following professional literature and progress in this part of Information Systems development (ERP implementation methodologies). Therefore, idea of authors of this work is to propose, develop and evaluate a situational method that supports the implementation of an ERP system. Additionally, method configuration should be specified that identify only those method fragments that are relevant for certain roles, e.g. project manager or ERP consultants. Finally, the utility of the whole situational method consisting of method fragments, procedure model/rules and method configurations should be justified by using the method in actual ERP implementations and evaluating the integrated artifact's utility. All process of proposing, developing and evaluating should be based on rigid DSR foundations heavily supported by experience of ERP

professionals and ASAP methodology (ERP implementation methodology provided by biggest ERP vendor). At the end, synergy between academia and industry should be an advantage in developing Situational Method Engineering as part of DSR; proving its applicability and power to describe actions/activities in real IT industry.

## References

1. Moon, Y.B. "Enterprise Resource Planning (ERP): a review of the literature," *International Journal Management and Enterprise Development* (4:3) 2007, pp 235-264.
2. Al-Mashari, M., Al-Mudimigh, A., and Zairi, M. "Enterprise Resource Planning: A Taxonomy of Critical Factors," *European Journal of Operational Research* (146:2) 2003, pp 352-364.
3. Scheurwater, M., De Swaan Arons, B., "ERP & Performance," *Compact KPMG IT advisory* (2009\_0) 2009, pp 10-16.
4. Al-Mashari, M., Zairi, M., et al. (2006) 'Enterprise Resource Planning (ERP) implementation: a useful road map', *International Journal of Management and Enterprise Development*, Vol. 3, Nos. 1–2, pp.169–180.
5. Dantes, G.R., Hasibuan, Z.A., "Measurements of Key Success Factors (KSFs) on Enterprise Resource Planning (ERP) Adoption", *IBIMA Business Review Journal*, 2010.
6. Davenport, T.H. "Putting the enterprise into the enterprise system," *Harvard Business Review* (76:4), 1998, pp. 121- 131
7. Ross, J. W. and Vitale, M. R. (2000). *The ERP revolution: Surviving versus thriving*, *Information Systems Frontiers* 2(2): 233-241.
8. Somers, T.M., Nelson, K. (2001) "The Impact of Critical Success Factors across the Stages of Enterprise Resource Planning Implementations", In *Proc of the 34th Hawaii International Conference on Systems Sciences*, Vol.8, 8016, IEEE Computer Society, Washington, DC, USA.
9. Hevner, A. R. et al. 2004. *Design Science in Information Systems Research*. *MIS Quarterly*. 28, 1 (2004), 75-105.
10. Janssens G., Kusters, R., & Heemstra, F. (2008). Sizing ERP implementation projects: An activity-based approach. *International Journal of Enterprise Information Systems (IJEIS)*, 4(3), 25-47.
11. Møller, C., Kræmmergaard, P., & Rikhardsson, P. (2004). *A Comprehensive ERP bibliography - 2000-2004*. Department of Marketing, Informatics and Statistics, Aarhus School of Business, IFI Working paper series(12), 54.
12. Somers, T.M., Nelson, K. (2001) "The Impact of Critical Success Factors across the Stages of Enterprise Resource Planning Implementations", In *Proc of the 34th Hawaii International Conference on Systems Sciences*, Vol.8, 8016, IEEE Computer Society, Washington, DC, USA.
13. E.J. Umble et al. (2003), "Enterprise resource planning: Implementation procedures and critical success factors," *European Journal of Operational Research* 146 241–257
14. Markus, M.L. and Tanis, C. (2000) *The enterprise systems experience – from adoption to success*. In *Framing the Domains of IT Research: Glimpsing the Future Through the 264* Markus et al. Past, Zmud, R.W. (ed.) (Pinna  $\square$  ex Educational Resources, Cincinnati, OH), 173–207.
15. Dolmetsch, R., T. Huber & Fleisch, E. (1998). *Accelerated SAP 4 Case Studies*, Institute for Information Management, University of St: Gallen.
16. Bhattacharjee, A. (2000). *Beginning SAP R/3 Implementation at Geneva Pharmaceuticals*, *Communications of the AIS* Vol. 4, No.

17. Parr, A. and Shanks G. (2000) A Model of ERP Project Implementation. *Journal of Information Technology* 15(2), pp 289-303.
18. Hevner, A. R. et al. 2004. Design Science in Information Systems Research. *MIS Quarterly*. 28, 1 (2004), 75-105.
19. Brinkkemper, S.: Method engineering: engineering of information systems development methods and tools. *Information and Software Technology* 38, pp. 275--280 (1996)
20. Bucher, T., Winter, R.: Dissemination and Importance of the "Method" Artifact in the Context of Design Research for Information Systems. In: Vaishnavi, V.K., Baskerville, R. (eds.) *Proceedings of the Third International Conference on Design Science Research in Information Systems and Technology (DESRIST 2008)*, pp. 39--59. Atlanta (2008)
21. Mirbel, I., Ralyté, J.: Situational method engineering: combining assembly-based and roadmap driven approaches. *Requirements Engineering* 11, pp. 58--78 (2006)
22. Brinkkemper, S. 1996. Method engineering: engineering of information systems development methods and tools. *Information and Software Technology*. 38, 4 (1996), 275-280.
23. Ralyté, J.: Reusing Scenario Based Approaches in Requirement Engineering Methods: CREWS Method Base. In: *Proceedings of the 10th International Workshop on Database and Expert Systems Applications (DEXA'99)*, 1st International Workshop on the Requirements Engineering Process (REP'99), pp. 305--309. Florence (1999)
24. Mirbel, I. and Ralyté, J. 2006. Situational method engineering: combining assembly-based and roadmap-driven approaches. *Requirements Engineering*. 11, 1 (2006), 58-78.
25. Gericke, A., Fill, H.G, Karagiannis, D., Winter, R.(2009): Situational Method Engineering for Governance, Risk and Compliance Information Systems DESRIST, ACM

# Data Reduction in Monitored Data

Xuesong Peng<sup>1,\*</sup>

Supervisor: Barbara Pernici<sup>1</sup>

<sup>1</sup>Politecnico di Milano, piazza Leonardo da Vinci 32, 20133 Milan, Italy  
xuesong.peng@polimi.it

**Abstract.** Nowadays, increasing time series data has brought new challenges in many domains because their massive instances, dimensions, speed and complexity. In order to solve this problem, data reduction techniques are becoming an integral part of future systems, especially for Monitoring System. Different from most data reduction techniques which are based on information theory, this paper is planning to explore a novel model-based method, which tries to build piecewise regression models only for correlated data with guidance of priori knowledge, avoiding unnecessary computation between unrelated data streams. Until now, we have designed a primal data reduction framework, corresponding experiments and evaluation criteria.

**Keywords:** data reduction; time series; model-based; monitored data.

## 1 Introduction

In the era of Big Data, numerous new data streams are generated every day, resulting extremely high-volume data from multiple sources in many domains, such as electricity grid, data center, smart building, etc. Those data streams are mainly based on sensing systems of physical environments and computing systems, i.e. Monitoring Systems, and most of Monitored Data can be described as time-series data, which is the representation of a collection of values obtained from sequential measurements over time <sup>[1]</sup>.

Modern information systems have to deal with a large amount of information, which always lies in massive data and requires many times of transmission, storing and extraction of data. Moreover, some of them are in continuous data stream, which make these problems even harder to solve. This cost-expensive process now becomes a bottleneck of modern information system, so how to reduce the quantity of stored data while maintaining the ability to derive informative values becomes a key problem to research. My Ph.D. research will be carried on the phenomena of data reduction process in monitoring system, especial streaming data, with two key properties of

interest, namely, performance of process and reserved information values. I will mainly focus on improving data reduction process by exploiting powers of knowledge models, which is a general term of models built on learnt knowledge. They can be simple correlation models describing correlations between data dimensions, as we used in CMBDR framework currently, or even logic-based models like some semantic models which describing complicate relations such as generalization, classification, etc. During my research, I will try to answer the following research question: Is it possible for knowledge models to help information systems improve their ability to do data reduction and information values retrieval? Currently, I'm assuming models are based on a priori knowledge, but it could also be an optional direction to investigate how to build models of monitored data. In this paper, some related algorithms and tools are studied, and based on their drawbacks, the idea of model-based data reduction is proposed. And in order to evaluate this idea, a possible initial approach named CMBDR (a novel model-based framework building recursive regression models to obtain a reduced representation of raw data) is designed and will be validated in future. And obviously, new algorithms of data reduction should be developed and combined with existing ones to implement this idea, which would be my future work.

The rest of paper is organized as follows. In section 2, we discuss the state of the art, explaining some common used data reduction techniques and their disadvantages. In section 3, as a candidate solution to the problem, we present CMBDR framework and mechanisms to implement. In section 4, evaluation mechanisms and criteria are defined to measure framework performance. Section 5 lists some interesting open issues related to CMBDR. We conclude the paper and introduce future work in section 6.

## 2 State of the art

A variety of techniques have been developed for data reduction in time series in the past few decades, and most of them are from the perspective of information theory. PCA (Principal Component Analysis) implements orthogonal transformation to convert possibly correlated variables to some linearly uncorrelated variables (principal components) based on a few observations<sup>[2,3]</sup>. PAA (Piecewise Aggregate Approximation)<sup>[4]</sup> is a simple dimensionality reduction method for time series, which reduce dimensionality with mean values of equal sized frames of original data. Some other common used reduction techniques are SVD (Single Value Decomposition), DFT (Discrete Fourier Transform) and DWT (Discrete Wavelet Transform).

Recently, some new methods are also introduced to implement data reduction in large systems. Cypress<sup>[5]</sup> is a new method supporting archiving and querying for massive time series data, it firstly transforms the single data stream into several sub-streams (called trickles) and then directly use some trickles to answer common queries (trends, histograms, and correlations), which doesn't need to reconstruct original data. Those trickles are generated by implementing filtering, down sampling, thresholding and random projection on original time series stream. Cypress framework carries out lossy compression to achieve high compression ratio, and at the same time it



remains to be effective to answer queries (reserving spikes, trends of original data) on compressed data, without reconstruction of original data.

YADING<sup>[6]</sup> is an end-to-end clustering algorithm which works on large-scale time series with fast performance and quality results employing some data reduction techniques. YADING provides theoretical proof on the lower and upper bounds of the size of the reduced dataset firstly, and then operates random sampling and dimensionality reduction (PAA) on original datasets.

In general, data reduction methods are all built based on data redundancy. In time series case, most of data redundancy lies in temporal repeatability and correlation between each series. And those correlations can be ubiquitous in variant systems in terms of monitored data, in which remarkably, data correlations are always resulted from real-world relations between monitored objects, including spatial relation and also logical relation. For instance, correlation between neighboring sensors placed in Smart Buildings, and collaborating servers in a data center.

As explained above, current data reduction methods are all based on information theory, which means before data reduction phase, they need to analyze data first to understand the repeatability and correlations. But all these methods neglect the semantic meanings of data in their process, causing much aimless computation which lower program performance. And that's also the biggest barriers hinder their implementation in big systems. So this paper goes in the opposite direction, by exploiting properties which can be apparent or easily inducted from existing data and knowledge to avoid aimless computation between uncorrelated data, proposes a new method to do data reduction in monitored data which exploit correlations known from pre-defined models.

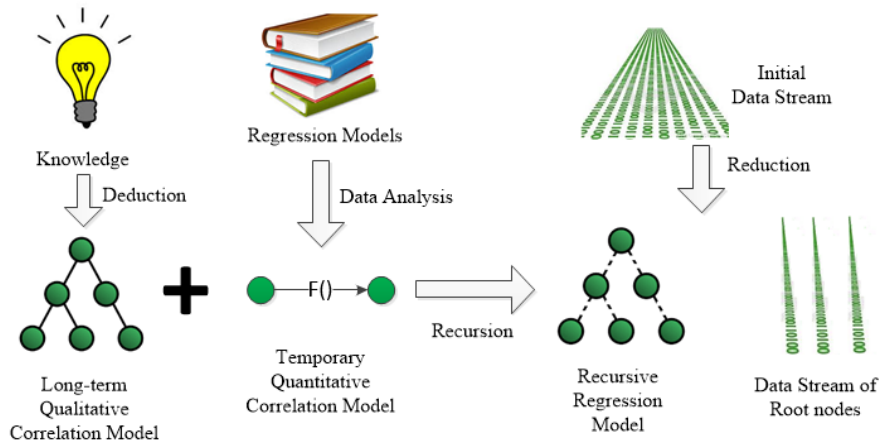
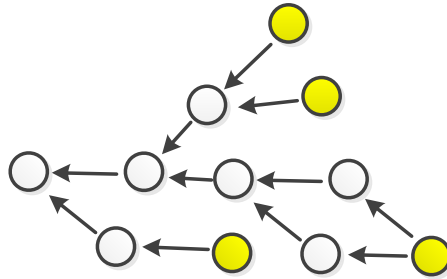

**Fig. 1.** CMBDR framework

### 3 CMBDR Framework

As an initial approach, CMBDR exploits correlation models because they can always give direct guidance on reduction process and can be easily obtained in many cases. Learning from the idea of replacing correlated time series data with regression models<sup>[7]</sup>, we propose a new framework for time series data reduction in monitored data, namely, Correlation-Model Based Data Reduction (CMBDR), as shown in **Fig. 1**. It exploits the power of a priori knowledge to find possible correlations between data streams, from which we can build several Correlation Models to describe the qualitative relations between data streams in long term. Then for data output in a short period (called compression window), multiple regression models can be applied to find a matching quantitative temporary relation (function  $F$ ), so that data is compressed because any values of one data stream can be predicted by the other. Moreover, based on recursion of these quantitative relations on correlation model, the recursive regression model could be built so that data of any nodes on the correlation model could be predicted with raw data stream of the root nodes. In this way, CMBDR saves time by only conducting analysis on correlated data whose relations are specified in the input correlation model.

Compared to other solutions, two highlights of CMBDR lie in the process-guiding correlation model and also recursion of regression which makes scalability possible. In this paper, CMBDR can exploit not only the rigorous correlation models which are derived from empirical data research (e.g. Bayesian Network of indicator correlations<sup>[8]</sup>), but also some simple models deduced from general experience (e.g. correlation between light, temperature and CO2 level in a greenhouse). In addition, not every arbitrary topology is qualified for the correlation model, the minimum requirement is Directed Acyclic Graph shown in **Fig. 2**, which specifies unambiguous correlation and provides only one recursion choice. When all nodes in the model rely on at most one other node, the model will become a tree-like model shown in **Fig. 1**. Similar to the definition of depth for nodes in a tree, we defined depth for nodes in the Directed Acyclic Graph as the maximum number of edges from the node to the graph's root nodes. Another thing needs to remind is, the so-called long-term correlation model is not permanent.



**Fig. 2.** Directed Acyclic Graph and its root nodes

Currently, CMBDR only exploits segmented dimensionality reduction method (piecewise regression) which assumed the correlation model is true, so the performance is highly dependent on the quality of input model. Although the compression ratio of CMBDR is probably less than some techniques above because of their exhaustive information theory analysis, the pre-defined model can make this framework avoid much more unnecessary computations.

In order to implement CMBDR and evaluate its performance, we propose the solution divided into several steps, listed as follows:

1. Initialize the input correlation model, testing dataset (multi-variable data streams)
2. Initialize parameters, namely, length of compression window, regression threshold (compared with matching degree to validate a regression model), etc.
3. Segment time series data stream into compression windows
4. In a compression window, carry out regression analysis for each pair of streams which has relations in the Correlation Model (in a Width-First-Search order)
5. If the best fitting regression model exceeds the regression threshold, compress data according to this regression model; otherwise, keep raw data
6. Go to step 3 until no more compression windows
7. Output regression model parameters and raw data of root nodes
8. Recover data with regression models and raw data of root nodes (in a Width-First-Search order)
9. Evaluate results

Since CMBDR framework is aimed to quickly find fitting regression models to quantify relationship between two variables which are in a stream manner, the computation complexity of regression analysis must be limited. So in this paper, only the following simple regression models are considered and the framework should give preference to the model with the least time complexity during regression analysis.

- Simple linear regression with time complexity of  $O(m)$
- Multiple linear regression with time complexity of  $O(m^2n)$
- Low polynomial regression

## 4 Evaluation Criteria

CMBDR framework conducts model-based regression analysis on monitored data to achieve data reduction with raw data of root nodes and the recursive regression model. In order to evaluate CMBDR, validation will be conducted with abundant experiments on specific monitored datasets:

- sensors outputs of ventilation facades in a smart building
- software and hardware information of a data center monitoring system

Aimed to find its ability to achieve less execution time, higher compression ratio, and better accuracy compared to some mainstream techniques (PAA, PCA, Rainmon<sup>[9]</sup>), following evaluation metrics are built:

- Compression ratio to demonstrate compressing performance of data reduction
- Total execution time to show processing speed on data streams
- Accuracy to reflect the informative values remained in compressed data

In specific to the accuracy aspects, instead of one specific criterion, we propose multiple criteria to meet different possible requirements from different applications, the criteria are as following:

- Root-mean-square deviation to measure total accuracy of compression, it represents standard deviation of the differences between raw data  $y$  and compressed data  $f$ , as shown in equation (1)

$$\text{RMSD} = \sqrt{E((f - y)^2)} \quad (1)$$

- Coefficient of determination, denoted as  $R^2$  to measure total goodness of fit of the compressed model, as shown in equation (2),  $y_i$  is raw value of original data and  $f_i$  is recovery value of compressed data for time series containing  $n$  values

$$R^2 = 1 - \frac{\sum_{i=1}^n (y_i - f_i)^2}{\sum_{i=1}^n (y_i - \bar{y})^2} \quad (2)$$

- Relative error to weigh informative values decreased by the data reduction method, as shown in equation (3),  $\eta$  is relative error,  $\epsilon$  is absolute error and  $v$  is range of data

$$\eta = \frac{\epsilon}{|v|} \quad (3)$$

- Pearson's Coefficient to measure correlation between data streams so that we can compare and find correlation variations after data reduction, as shown in equation (4),  $\gamma$  is Pearson's Coefficient,  $X_i$  and  $Y_i$  are sample values for time series  $X$  and  $Y$  containing  $n$  values,  $\bar{X}$  and  $\bar{Y}$  are mean values of  $X$  and  $Y$

$$\gamma = \frac{\sum_{i=1}^n (X_i - \bar{X})(Y_i - \bar{Y})}{\sqrt{\sum_{i=1}^n (X_i - \bar{X})^2} \sqrt{\sum_{i=1}^n (Y_i - \bar{Y})^2}} \quad (4)$$

- Performance of some applications running on both raw data and compressed data (e.g. clustering) to validate practicability of CMBDR, and also as important indicators of reserved informative values in compressed data

## 5 Open issues

CMBDR is a new data stream reduction framework based on correlation models which is from knowledge. Although this paper has discussed some important aspects of this framework, there are still many open issues not covered, and solving these issues would be very helpful to enhance CMBDR. So in this part, we will talk about three crucial open issues, namely, regression abnormal, error prediction and error control.

Regression abnormal implies the moments when there is no regression model matched for the time series data in a compression window in regression analysis. This is mainly because the simple and limited regression models are not always capable of finding a well-fitting regression model, especially when the data vary exponentially. Currently, CMBDR exploits regression threshold to detect these abnormal, and once an abnormal is detected, the framework will directly use raw data. Some extensions could be researched to compress these abnormal windows, such as abnormal behavior detection based on machine learning algorithms.

Error prediction and error control paradigm should also be investigated to help to improve CMBDR performance. Firstly, based on the historical data of errors, confidence could be attached to the edges in the long-term correlation model, making it possible to maintain relations in a dynamic way, so being able to control unnecessary analysis on outdated relations. Moreover, consider the recursive regression model in **Fig. 1**, it is obvious that errors of a child node will be probably larger than his father's in the compressed data. And the deeper a node is, the more information loss it will have. So analysis could be carried out to find relations between errors of nodes on the recursive regression model, upon which we can build error prediction model. In the meanwhile, some error control methods could also be exploited to improve accuracy for those deep nodes. For instance, use raw data for some nodes in the regression model, so that errors of father nodes will not be inherited by their children. Alternatively, some other reduction techniques could also be exploited here, such as down sampling, PCA etc.

## 6 Conclusion and future work

As an initial approach to solve the monitored data reduction problem, we have presented CMBDR, a framework operating massive multivariate data stream, based on a correlation model. It applies regression analysis to quantify correlations between data streams and exploits recursion on correlation model to achieve reduced representations of raw data. We designed evaluation criteria to measure performance, and also discussed some crucial open issues which can improve CMBDR performance.

Future developments of this paper are to implement CMBDR framework in two scenarios, the first one is ambient environment monitoring with multiple sensors (temperature, humidity, air speed, etc.), and the second one is a data center monitoring system which collects various software and hardware information. Also, in order to extend CMBDR, the paradigm of error prediction and control discussed in section 5 will be researched, mainly focusing on how modeling of information and learning techniques could support each other. Furthermore, collaborations of CMBDR and other data reduction techniques are worthy of investigation.

## References

1. Esling, Philippe, and Carlos Agon. "Time-series data mining." *ACM Computing Surveys (CSUR)* 45.1 (2012): 12.

2. Jolliffe, Ian. *Principal component analysis*. John Wiley & Sons, Ltd, 2002.
3. Wikipedia contributors. "Principal component analysis." *Wikipedia, The Free Encyclopedia*. Wikipedia, The Free Encyclopedia, 21 Mar. 2015. Web. 30 Mar. 2015.
4. Keogh, Eamonn, et al. "Dimensionality reduction for fast similarity search in large time series databases." *Knowledge and information Systems* 3.3 (2001): 263-286.
5. Reeves, Galen, et al. "Managing massive time series streams with multi-scale compressed trickles." *Proceedings of the VLDB Endowment* 2.1 (2009): 97-108.
6. Ding, Rui, et al. "YADING: Fast Clustering of Large-Scale Time Series Data." *Proceedings of the VLDB Endowment* 8.5 (2015).
7. Carvalho, Carlos, et al. "Improving prediction accuracy for WSN data reduction by applying multivariate spatio-temporal correlation." *Sensors* 11.11 (2011): 10010-10037.
8. Vitali, Monica, Barbara Pernici, and Una-May O'Reilly. "Learning a goal-oriented model for energy efficient adaptive applications in data centers." *Information Sciences* (2015).
9. Shafer, Ilari, et al. "Rainmon: an integrated approach to mining bursty timeseries monitoring data." *Proceedings of the 18th ACM SIGKDD international conference on Knowledge discovery and data mining*. ACM, 2012.

# Enrichment of Business Process Management with External Data

Pierre-Aymeric MASSE

Orange Labs, 38-40 Rue du Général Leclerc, 92130 Issy-les-Moulineaux, France

[pierreaymeric.masse@orange.com](mailto:pierreaymeric.masse@orange.com)

Institute Mines-Télécom, Télécom Bretagne, UMR CNRS 6285 Lab-STICC, 29238

Brest, France

[pa.masse@telecom-bretagne.eu](mailto:pa.masse@telecom-bretagne.eu)

Université Européenne de Bretagne, 29238 Brest, France

**Abstract.** Organizations have an increasing need to adapt faster their Information Systems (IS) to technical, functional or legal changes. Orange, a French telecom operator, works on the adaptation and the improvement of their business processes (BP), especially those related to Customer Relationship Management (CRM). One of the challenges is to help a business expert to efficiently and quickly adapt a BP. Indeed, this challenge includes the need to understand the reasons why the execution of the BP does not satisfy the business needs and the business goals. In this research paper, we propose to study how to identify these reasons based on the analysis of relevant data which include process generated data (such as logs and database data), and contextual data. To address this research question we plan to explore two directions: semantic enrichment of BP in order to detect relevant data and BP optimization to align BP to business goals on the one hand and to the relevant data on the other hand.

**Keywords:** Business Process Management, Semantics, Process optimization

## 1 Introduction

The increasing adoption of Business Process Management (BPM) [14] in recent years has resulted in a large standardization of processes. Companies are confronted to frequent changes. Consequently, adapting and continuously improving BPs, in order to align them to the changes of the company, is a key challenge to stay competitive. In practice, companies aim to reduce the time needed to take into account these changes. Currently, this is done manually by a business expert who analyzes the various components (such as business goals [18], roles and actors related to BP activities, process execution, business data and external data) and correlate them each other in order to deduce relevant adaptations to apply on the BP.

One existing approach to speed up the adaptation and the improvement of BPs is to dynamically detect relevant changes to apply on the BP execution

(e.g. select a specific path). Authors in [14] surveyed existing solutions in this field. One solution is the concept of flexible process. It consists in incorporating alternative execution paths within the BP model so that the selection of the most appropriate execution path can be done at the runtime for each instance (flexibility by design). Another solution is the concept of configurable process [5], which consists in designing a model that provides a complete and integrated set of all possible process configurations. Afterwards, before the runtime, such a model can be configured to a specific solution by restricting the behavior of the configurable process model. For example, activities may be skipped or blocked during the configuration time.

We identified two limitations of these approaches. Firstly, in both cases, all possible adaptations must be well defined at the BP design time. Consequently, it significantly limits the adaptation scope. Secondly, these solutions are well suited to handle known exceptional and temporary situations in which the adaptation of the BP execution is necessary, but not for long term changes, in which the adaptation of the BP model itself is required.

At Orange (a French telecommunication operator), where the PhD takes place, there are currently two research projects related to this research field. The first ongoing project, named PRODIA, is based on process mining techniques [13] to detect BPs as they are executed by involved parties. Its goal is to provide experts with a comprehensive view of the execution of BPs in order to continuously improve them. The second project is based on web semantic techniques to speed up the implementation of BPs by matching BPs activities with Web services through ontology concepts [17].

The aim of this PhD thesis is to support business experts in the adaptation of the BPs. To achieve this goal, it is necessary to:

- firstly detect relevant data which could influence the BP execution;
- secondly correlate these data with the business goals and the BP model in order to understand how these data influence the BP execution;
- finally suggest to the business expert changes to operate on the BP model in order to align it to the business goals on the one hand and to the relevant data on the other hand;

Our work could be used by Orange to improve its CRM, and more specifically the customer subscription to a telecommunication service business process. Let's suppose that one business goal of this BP is to have the rate of customer who abandons the subscription process below 30%. Using traditional process mining techniques we can detect that the abandon rate is higher than our objective. Current techniques however do not provide additional support to the business expert to understand "why" the BP does not satisfy the business goal. The proposed thesis aims to fill this gap by not only providing solutions to support the expert in understanding the reasons that make a BP does not satisfy a business goal, but also to suggest BP adaptations accordingly.

The rest of the paper is structured as follows. Section two, we briefly narrates the closely related work. In section three we present the research problem. A



research methodology is then detailed in the section four. Finally, the section five presents the summary of the paper.

## 2 Related work

BPM is characterized by the BP lifecycle definition [13], which contains seven stages: (re)design, analysis, implementation, (re)configuration, execution, adjustment, and diagnosis. Though the thesis is related to all phases of the BP lifecycle, a particular focus is given to the (re)design, the analysis, the execution and the diagnosis phases, as they directly impact the BP transformation. In the (re)design phase a new BP model is created or an existing BP model is adapted. In the analysis phase a candidate model and its alternatives are analyzed to validate the model (e.g. avoid deadlocking, detect dead paths, etc.). Then, after the implementation and the configuration phase, the execution phase orchestrates the different BP activities in accordance to the designed model. At the end of this lifecycle, in the diagnosis phase, the enacted BP is analyzed, which may trigger a new BP redesign phase. The diagnosis phase usually relies on the logs and data generated by the different instances of the BP.

Improving the BP adaptations process has been investigated extensively. We classify existing approaches into 3 different categories.

### BP variant solution

This first category concerns existing solutions that adapt the model before its execution according to a particular situation.

The authors in [14] survey BPM research field. They review BP variant solutions where the process model is subject to continuous evolution. It broaches the difference between flexible (run-time decision) and configuration BP (configuration-time decision).

Configuration BP consists in incorporating alternative execution paths within the BP model so that the selection of the most appropriate execution path can be done before the runtime for each instance. It also enables to merge several BP model from the same family (all related to the same domain) into a configurable BP model in order to reduce the number of BP managed by the BPM system and team. Configuration BP consists in having a model providing a complete and integrated set of all possible BP configurations. Afterwards, such a model can be configured to a specific solution by restricting its behaviour. For example, activities may be skipped or blocked during the configuration time. On the opposite, variability by extension contains the most common behaviour. Afterwards, the model is extended (e.g. adding new activities) during the configuration time to serve a specific situation.

The paper [5] presents the configurable workflows approach that proposes to customize the BP model by applying, “hiding” or “blocking” operations to BP activities. “Hiding” operation makes an abstraction of the model and hides some activities, but these activities are still executed. “Blocking” operation removes a path from the model. [19] proposes a framework to capture the variability of

a BP by processing a set of business rules. Business rules cover all aspects of the business logic in BPs. A non-deterministic goal-driven BP inference engine is used to create the BP model. Consequently, business expert will focus on the design of business goals instead of specifying the detailed control and data flows. Another approach to identify the variants of a BP is proposed in [9] which is based on applying a questionnaire by domain. Based on the answers of the business expert, the system generates the most suitable BP model variants.

These approaches can also be used as a context aware BPM solution. In this field, [12] provides a top layer approach making automatic context-based decisions. This context-aware approach takes the context as relevant data to dynamically configure the BP.

The first limitation of existing BP variant solutions is the effort involved in constructing and maintaining customizable BP models beyond trivial examples. Indeed, The amount of information required to construct and to maintain such a model grows exponentially with the complexity of the BP [14]. Consequently, it significantly limits the adaptation scope. These solutions enable business experts to find a tradeoff between the number of BP to design and their complexity. The second limitation resides in the diagnosis phase. Indeed, in practice, BPs variant do not enable an accurate analysis using traditional techniques based on event logs such as process mining. This is due to the generation of multiple instances which depends on contexts that is not always accessible or taken into account by these techniques.

### Semantic techniques

The second category harnesses semantic techniques to improve the BPM lifecycle (semantics-based BPM (sBPM) [4]). It consists in adding semantic annotations to a BP model. Semantic techniques are based on ontologies. Authors in [8] investigate current approaches in sBPM, especially those related to the existing gap between the business community and the IT community (e.g. the finished European-funded project, FUSION<sup>1</sup>, which worked on a semantic framework to easily allow collaborative work of several enterprises in a BP). Semantic based approaches also enable for instance:

- to propose an auto-completion mechanism to speed up the modeling process [2]. The recommendation system determines possible activities set based on models previously created and similarity computing;
- to accelerate the transformation of the model into a valid implementation using natural language processing techniques and semantic technologies. The authors in [1] study how to automatically match BP activities with Semantic Web Services (SWS) description in order to transform the BP model into an effective implementation. The proposed framework detects automatically the web services to use for each BP activity. This matching process is based on an ontology, built around the e-Tom Framework<sup>2</sup>. Based on semantic

<sup>1</sup> [www.fusionweb.org](http://www.fusionweb.org)

<sup>2</sup> [www.tmforum.org](http://www.tmforum.org)

description of activities, in the BP model, and web services (SWS) in the service platform, the proposed framework detects automatically which web service to use to achieve a BP activity;

- to link BPs activities with BP data in order to perform better diagnosis [11]. This approach could be extended to handle additional data, which are not especially produced by the BP but still influence it. These data are interesting to correlate with the BP but difficult to identify by business experts because they are not directly related to the BP;

### Deep analysis and optimization

Another research area related to our work is BP optimization and deep analysis. BP optimization aims to study how a BP can be improved. BP optimization based on quantitative measures of goals achievement is not yet well addressed in the literature [16]. Deep analysis refers to a set of techniques that apply sophisticated data processing techniques to extract information or knowledge from large data set.

For instance, the framework proposed by [7] analyzes BP data and operational data, in real-time, to detect a predicted metric deviation. It uses mining techniques to generate decision rules based on BP data and the accomplishment of the BP goals. A recommendation mechanism evaluates the most compliant rule to fix the BP instance deviation. However, this approach uses only data of the BP instances to dynamically fix the BP deviation though the deviation could be caused by other data (e.g. road traffic which causes additional delay in the delivery BP). Another approach that use data of the BP instances is detailed in [3]. This framework recommends to a user the next action based on:

- the identification of the data which provides information about intentions;
- the identification of the intentional cluster of events associated with an intention and its naming;

The authors in [11] show an approach to match BP data and operational data in order to make a deep business analysis. The proposed framework correlates two types of BP data: those stored in the BPM and those stored in the IS.

To improve process mining results, an analysis approach is proposed in [15] which takes into account the BP execution context. This technique uses event logs with a clustering algorithm to regroup closest BP execution.

Another solution that uses context is proposed by authors in [6]. AGENT-WORK provides healthcare domain with a comprehensive support for automated BP adaptation. This framework is based on Event/Condition/Action rules to detect the execution of exceptional activities in the BP in order to suggest BP relevant adaptations. The actor can accept these adaptations to apply to the current BP instance and save the current context in the framework. In addition, it tries to apply predictive adaptations based on similarity between the current and the previously encountered contexts.

### 3 Research Problem

The aim of this thesis is to study how to accelerate the adaptation of BP to optimize them based on:

- business goals;
- operational data such as the number of achieved subscription;
- non-operational data (external data) such as the context in which the BP is instantiated and executed;
- BP data such as an activity duration;

We define Operational Data (OD) as any data processed within the BP but not stored directly in the BPM system; data stored in BPM system is then named BP Data (BPD) [11]. We define Non-Operational Data (NOD) as any data that are not directly generated or modified by the BP (e.g. Urban Traffic and Weather in Delivery BP), we also refer to these data as external data.

Unlike BPD and OD, NOD are not directly linked to the BP. Consequently, it is currently difficult for an expert, and even for a machine, to correlate BP execution with these data. Therefore, to investigate this issue, we define several research questions:

- How to detect relevant data that impact BP execution based on business goals and BP model?
- How to correlate these data with BP instances to explain business goals deviation (metric deviation)?
- How to identify BP adaptations that address the goals deviation?

### 4 Research methodology

In order to better respond to our research questions, we plan to explore two directions which are the result of the early work of the thesis.

#### 4.1 Research directions

##### **Semantic Enrichment for Enhanced Diagnosis**

This first direction aims to set up the foundation for a solution for linking data (OD, NOD, and BPD) to a BP. We propose to add semantic annotations to a BP in order to detect relevant data which impact BP execution. This proposal impacts the following BP lifecycle phases:

##### *(Re)Design and analysis*

During the design and analysis phase, our proposal consists in enabling business experts to add semantic annotations to each activity of the BP on the one hand and to the associated business goals on the other hand. This implies the definition of a tool that supports the business experts in this task, as well as the corresponding methodology. Based on the initial semantic annotations (manually specified by the business experts), the BP model, and business goals, the

tool must be able to find out additional concepts that could impact the BP execution. This mechanism explores ontological and BP relationships to discover new relevant concepts. These new concepts are validated or not by business experts.

#### *Execution*

During the execution phase, our proposal consists in retrieving the data that could impact the execution of the BP. Based on semantic annotations discovered at the design and analysis phase, these data are clearly identified. Nevertheless, it still remains important, especially for volatile data, to store them and associate them to the BP instance for further diagnosis.

#### *Diagnosis*

Our challenge in the diagnosis phase is to detect how the data impact the BP execution. From the technical point of view, this consists in correlating the data related to the concepts inferred in the design phase, and retrieved during the execution phase with the different instances of the BP. Clustering techniques (unsupervised learning) could be applied to detect such correlations.

### **BP Optimization**

Semantic enrichment aims to provide business experts with all necessary elements that could explain “why” a BP doesn’t respect a business goal. The aim of BP optimization is to design and implement a solution that suggests BP adaptations to a business expert; adaptations that align the BP to the business goals, taking into account the data environment. To achieve this goal, we analyze all the data (BPD, NOD, and OD) to highlight possible adaptations and to align the BP as well as possible to business goals. A candidate approach is the model-transformation by applying the goal-model to the BP model [10]. Model-transformation is based on rules that transform a given source model to a target model, according to specified meta-models.

## **4.2 Evaluation**

In order to evaluate our approach we are currently developing a proof-of-concept which implements our proposals. We look forward to apply this prototype to a customer relationship use case in order to evaluate it. As our proposals are intended for business experts, we plan to interview them based on qualitative evaluation questionnaire in order to validate the results.

## **4.3 Research method**

We divide our research method to several steps. This method will lead the PhD thesis with a methodology to provide scientific results. First we study the problem which consists in:

## BPM Enrichment with External Data

- studying the state of art of the BPM and related research fields;
- defining the research questions and highlighting the state of the art limitations;
- proposing new concepts and continuously studying the state of the art accordingly;
- defining the evaluation criteria;

Then, we plan to design the proposed concepts that respond to the different limitations identified in the state of the art. At this stage of our research progress we identified the following items:

- designing a BPM solution based on semantic to detect relevant data (data that influence the BP);
- designing a goal-driven BPM to improve relevant data selection;
- designing BP analysis solution that highlights the reasons of a metric deviation regarding business goals;
- designing BP optimization method, optimization that aims to redress a metric deviation;

Finally, we plan to evaluate these solutions and raise their benefits and limitations. We intend to:

- implement the prototype and apply it to customer relationship BPs;
- evaluate the proposals according to identified criteria;

## 5 Summary

In this paper, we detailed and motivated our PhD thesis subject. The main research question we are trying to address is how to speed up the adaptation of BPs to optimize them based on data that influence them and their business goals? We subdivide the main research question into several elementary sub-questions. Then, we reviewed the state of art to position our work. Finally, we elaborated the plan of the PhD and proposed to deeply study two themes: Semantic Enrichment of BP for Enhanced Diagnosis and BP optimization.

### 5.1 Acknowledgements

I want to thank my supervisors, Dominique Seminel (Orange), Jacques Simonin (Telecom Bretagne), Nassim Laga (Orange) and Patrick Meyer (Telecom Bretagne), for many hours of discussion and feedback regarding to the research topic and for their help to formulate the thesis subject.

## References

1. Assy, N., Yongsiriwit, K., Gaaloul, W.: A Framework for Semantic Telco Process Management - An Industrial Case Study. *Intelligent Systems Design and Applications (ISDA)* pp. 44–49 (2014)

2. Betz, S., Klink, S., Koschmider, A., Oberweis, A.: Automatic User Support for Business Process Modeling. In: Proceedings of the Workshop on Semantics for Business Process Management, pp. 1–12 (2006)
3. Epure, E.V., Hug, C., Deneckere, R., Brinkkemper, S.: What Shall I Do Next ? Intention Mining for Flexible Process Enactment. In: Advanced Information Systems Engineering, pp. 473–487. Springer International Publishing (2014)
4. Fleischmann, A.: What Is S-BPM ? In: Buchwald, Hagen and Fleischmann, Albert and Seese, Detlef and Stary, C. (ed.) S-BPM ONE Setting the Stage for Subject-Oriented Business Process Management, pp. 85–106 (2010)
5. Gottschalk, F., Van Der Aalst, W.M., Jansen-Vullers, M.H.: Configurable Process Models A Foundational Approach. In: Reference Modeling, pp. 59–77. Physica-Verlag HD (2007)
6. Greiner, U., Rahm, E., Robert, M.: AGENTWORK : a workflow system supporting rule-based workflow adaptation. Data & Knowledge Engineering pp. 223–256 (2004)
7. Gröger, C., Schwarz, H., Mitschang, B.: Prescriptive Analytics for Recommendation-Based Business Process Optimization. In: Business Information Systems, vol. 17th Inter, pp. 25–37 (2014)
8. Hoang, H.H., Tran, P.c.T., Le, T.M.: State of the Art of Semantic Business Process Management : An Investigation on Approaches for Business-to-Business Integration pp. 154–165 (2010)
9. La Rosa, M.: Managing Variability in Process-Aware Information Systems by. Ph.D. thesis (2009)
10. Popp, R., Kaindl, H.: Automated Adaptation of Business Process Models Through Model Transformations Specifying Business Rules. In: CAiSE-Forum-DC 2014. pp. 65–72 (2014)
11. Radeschütz, S., Mitschang, B., Leymann, F.: Matching of Process Data and Operational Data for a Deep Business Analysis. In: Springer London (ed.) Enterprise Interoperability III, pp. 171–182 (2008)
12. Tavares Nunes, V., Werner, C., Santoro, F.M.: Dynamic Process Adaptation : A Context-aware Approach. In: Computer Supported Cooperative Work in Design (CSCWD), 2011 15th International Conference, pp. 97–104 (2011)
13. Van Der Aalst, W.M., Al.: Process Mining Manifesto. Business Process Management Workshops 99, 169–194 (2012)
14. Van Der Aalst, W.M., All: Business Process Management: A Comprehensive Survey. ISBN Software Engineering 2013, 1–37 (2013)
15. Van Der Aalst, W.M., Bose, R.J.C.: Context Aware Trace Clustering. In: SDM, pp. 401–412 (2009)
16. Vergidis, K., Member, S., Tiwari, A., Majeed, B.: Business Process Analysis and Optimization : Beyond Reengineering. IEEE transactions on systems, man, and cybernetics 38(1), 69–82 (2008)
17. Wang, X.H., Zhang, D.Q., Gu, T., Pung, H.K.: Ontology Based Context Modeling and Reasoning using OWL 3. In: Pervasive Computing and Communications Workshop. pp. 18–22 (2004)
18. Yu, E.S.k.: Modelling strategic relationships for process reengineering. Social Modeling for Requirements Engineering 11 (1995)
19. Zeng, L., Flaxer, D., Chang, H., Jeng, J.j.: P LM f low Dynamic Business Process Composition and Execution by Rule Inference pp. 141–150 (2002)

# Integrating the Internet of Things with Business Process Management: A Process-aware Framework for Smart Objects

Giovanni Meroni<sup>1</sup>

Politecnico di Milano – Dipartimento di Elettronica, Informazione e Bioingegneria  
Piazza Leonardo da Vinci, 32 - 20133 Milano, Italy  
[name]. [surname]@polimi.it,

Supervisor: Pierluigi Plebani<sup>1</sup>

**Abstract.** Due to the achievements in the Internet of Things (IoT) field, Smart Objects are often involved in business processes. However, the integration of IoT with Business Process Management (BPM) is far from mature: problems related to process compliance and Smart Objects configuration with respect to the process requirements have not been fully addressed yet; also, the interaction of Smart Objects with multiple business processes that belong to different stakeholders is still under investigation. My PhD thesis aims to fill this gap by extending the BPM lifecycle, with particular focus on the design and analysis phase, in order to explicitly support IoT and its requirements.

**Keywords:** Business Process Management System, Internet of Things, Process compliance, Process monitoring, Smart Object, Business Process Management, Multimodal Transportation, Smart Container

## 1 Introduction

During the last years, the growing interest for the Internet of Things (IoT) has been manifested by both the academic and industrial world. The IoT is based on the idea of Smart Objects, which are devices that decentralize computation and data acquisition by moving them into the physical world. Because of their diffusion, solutions for executing business processes relying on Smart Objects are becoming more and more common.

However, as stated by Haller et al. [1], the integration of IoT with business processes is far from trivial: data collected by sensors may be unavailable or have inconsistent quality and, since part of the process execution is delegated to Smart Objects and often involves multiple actors, it is difficult to assess the compliance of a process. It is also worth noting that Smart Objects differ from traditional services as they have reduced computational power and limited battery life. In such a scenario, mechanisms for configuring Smart Objects according to the process requirements and the capability of assessing the compliance of the control



and data flows with respect to the process definition would significantly ease integration tasks.

According to Weske [2], the Business Process Management lifecycle can be divided into four phases: (i) design and analysis, where business processes are modeled according to real world requirements; (ii) configuration, where business processes are implemented by a software solution; (iii) enactment, where business processes are instantiated and their executions logged; (iv) evaluation, where process logs are analyzed to assess the consistency between process models and their execution.

During my PhD I aim to investigate the integration of the Internet of Things with business processes by developing process-aware Smart Objects and by extending the Business Process Management lifecycle in order to explicitly support Smart Objects.

The rest of this document is structured as follows. Section 2 outlines the main research questions that I want to answer. Section 3 focuses on the multimodal transport domain to show the importance of the research questions for a significant application domain. Section 4 proposes a solution that will support process-aware Smart Objects. Section 5 analyzes the state of the art. Finally, Section 6 outlines a tentative schedule for my research activities.

## 2 Research Questions

The adoption of the IoT can impact all the phases of the Business Process Management lifecycle:

**Design and analysis** The process model will allow the user to define for each business activity which data will be collected by Smart Objects, which conditions will determine the start and end of the activities, and which constraints on sensor data must be satisfied to consider activities successfully completed.

**Configuration** Smart Objects will be configured to collect data related to process activities with the specified quality level, according to the process model definition.

**Execution** Smart Objects will be process-aware by being able to identify and log the execution order of business activities thank to their starting and ending condition. They will also constantly check data constraints in order to log whenever they are not satisfied.

**Evaluation** The process compliance will be assessed by analyzing the process trace logged by Smart Objects to identify control and data flow violations.

Initially, I will focus on the design and analysis phase by enriching current process modeling notations with constructs able to explicitly define Smart Objects, their roles, and their needs inside business processes. Subsequently, I will also extend the other phases to support, take advantage of, and validate the newly introduced process model notations.

To reach such achievements, I will investigate the following research questions:

- RQ1 - How can we monitor the process execution?** I aim to monitor the process execution flow by determining which activities are running. I also want to reach such achievement without relying on explicit start and termination messages addressed to specific activities, but instead inferring such conditions by analyzing events captured by Smart Objects (i.e., when their position is within a specific area).
- RQ2 - How can we define requirements on activity data?** I aim to support the definition of requirements on sensor data related to process activities. In this way, the business process will drive the configuration of sensors, thus guaranteeing that sensor data needed for the correct execution of activities will be available and with a quality matching the requirements. If sensors are managed by external gateways (i.e., other embedded computing devices), requirements could also affect the computation done at node level.
- RQ3 - How can we identify process execution violations?** I aim to identify process violations by both checking the correct execution order of process activities and the compliance of activity-related data with constraints specified during the process design phase. I also want to do that directly on each Smart Object.
- RQ4 - How can we support multiple actors?** I aim to support the concurrent execution of processes that are designed by multiple actors and could partially or totally overlap during execution. Such a question is not trivial, since different actors might have different process definitions, constraints, and/or requirements on activities running at the same time. Therefore, I will define process merge and conflict resolution mechanisms.

### 3 Case Study: Multimodal Transportation

My main case study, which I will use for the problem identification and motivation, refers to multimodal transportation, since most of the research questions will directly address the currently unfulfilled needs of the stakeholders involved in such a domain.

Multimodal transportation concerns the planning and enactment of transportation of goods via multiple means of transport, each one typically belonging to different shipping companies, for each single shipping. Moreover, goods often belong to different manufacturers and/or are addressed to different customers. Such a task is far from trivial, since each stakeholder needs to track the status of the goods (i.e. position, conditions, etc.) during each shipping phase that involves its participation.

To fulfill these needs, research efforts have been spent in putting some intelligence into shipping containers, which are often used to aggregate goods during multimodal shipping, turning them into Smart Containers, that is, Smart Objects. Such Smart Containers are usually equipped with sensor networks, a Single Board Computing (SBC) device, and a communication device for exchanging data with information systems.

However, such solutions are usually based on a static approach: the sensor network configuration does not change during the transportation process, the

nature of shipped goods is not taken into account, and they are usually tailored to a specific business process often involving a single stakeholder. In the real world this is not the typical case. Several factors, such as the content of the container, the capabilities of the sensor network, and the current phase of the shipping process may determine a variation on the requirements on sensed data. Moreover, as previously said, the nature of multimodal shipping involves the active participation of multiple stakeholders. Each party has its own business processes with different requirements on sensor data according to each specific process activity. Therefore, the compliance of each shipping process with respect to the data and control flows defined by stakeholders in their business processes cannot be taken for granted, and its assessment is far from trivial.

## 4 Solution

As discussed in the previous section, with particular focus on the multimodal transportation, current solutions based on Smart Objects lack the capability of dynamically configuring sensors with the precision required. Each activity of the business process must take into account the currently involved stakeholders. Moreover, mechanisms able to assess process compliance have not been introduced yet.

I envision a scenario in which Smart Objects are autonomous elements able to communicate with external entities. These external entities are the stakeholders that can: ask for the status of a Smart Object, and inform the Smart Object about the process in which it is involved. In order to do so, Smart Objects must be aware of the currently running process activities, and, for each activity, they must know the requirements on sensor data that have to be fulfilled.

To support this scenario, a Smart Object have to be equipped with: (i) a sensor network, (ii) a Single Board Computing (SBC) unit, and (iii) a communication interface. The sensor network collects information concerning the environment in which the Smart Object operates; the SBC executes a complete software stack, and different applications are installed; finally, the communication interface allows the interaction with external systems.

Among the others, the SBC will run a lightweight Business Process Management System (BPMS), a sensor configuration manager, a sensor data evaluator, and sensor interface modules, as shown in Figure 1.

The BPMS is the core of the solution: it will be responsible for keeping track of all processes belonging to each involved stakeholder, thus allowing them to orchestrate the Smart Object. In order to do so, it will be able to figure out which activities are currently running, to activate a proper configuration of the monitoring system. However, as conditions that determine the execution of activities rely on events that can be external, the BPMS will also deal with process choreography. It is worth noting that in many application contexts, such as multimodal transportation, some of the actual involved stakeholders and their business processes are known only at run-time. For this reason, each time a new

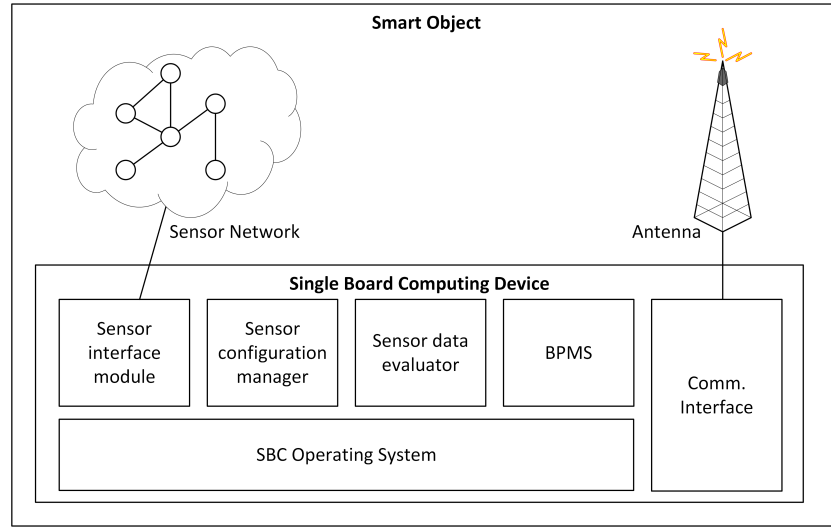

Fig. 1. Software modules.

stakeholder is involved, its business process definitions have to be downloaded and taken into account. Such a component will therefore answer RQ1 and RQ4.

The sensor configuration manager, on the other hand, will be responsible for determining stakeholders' requirements on sensor data. It will extract and interpret requirements from the process definition provided by the BPMS, and it will opportunely instruct the sensor interfaces to provide data that meet such requirements. Such a component will answer RQ2.

Finally, the sensor data evaluator will be responsible for verifying the compliance of sensor data to the constraints defined for the currently running activities, and for reporting violations of such constraints. Such a component will answer RQ3.

In order for these modules to automatically understand the process definitions and their specifications on data, I propose to extend such business process definitions with the following annotations on activities:

**Start and termination conditions** Such annotations will specify which conditions on process data determine the beginning or the end of a specific activity. This will allow the BPMS to implicitly infer the process trace (i.e. the sequence of activities carried out during process execution), and therefore to identify violations in the control flow.

**Data requirements** Such annotations will instruct the sensor configuration manager to provide data with the specified quality requirements, thus enforcing process compliance with respect to the data flow.

**Data constraints** Such annotations will impose constraints on data by specifying which conditions should or should not happen, thus allowing the sensor data evaluator to detect violations related to process data.

## 5 Related Work

Some research efforts have been spent on integrating the Internet of Things with business processes. Meyer et al. [3] propose to extend the BPMN 2.0 notation to model smart devices as process components. This approach keeps the process knowledge on the information system, and no process fragments are introduced on smart devices.

Thoma et al. [4] propose to model the interaction with Smart Objects in BPMN 2.0 as activity invocations for simple objects, or as message exchanges with pools representing the whole Smart Object for more complex ones. This way one can distribute parts of the process on Smart Objects. The limitation of this work is the lack of details concerning how to deal with data uncertainty or how to define data requirements.

Tranquillini et al. [5] propose a framework that employs BPMN for driving the configuration of a Wireless Sensor Network (WSN). Since BPMN is used only at design time for defining the business process, and then it is converted into binary code executable by the WSN, introducing changes in the process definition at runtime is difficult. Also, simultaneously supporting multiple processes within the WSN is not feasible with this framework.

Schief et al. [6] propose a centralized framework that extends the process design and execution phases of BPM by taking into account events generated by Smart Objects. Furthermore, this framework provides data quality mechanisms for evaluating events and sensor data. My proposal differs from this contribution by distributing process knowledge, which will be directly embedded in Smart Objects, and by explicitly defining requirements on sensor data, to better enforce and validate process compliance with respect to both the process execution and the data flows.

Concerning process compliance, such a topic has been widely studied during the last decade. However, as stated by Kharbili et al. [7], very few process compliance solutions exist that extend compliance checking beyond control flow. They do not consider data flows and the timeliness of activity data, aspects that are critical for the research questions. Awad et al. [8] try to address these open issues by proposing an extension of the BPMN notation, named BPMN-Q, able to define constraints also on the data exploited by business process activities. Ly et al. [9] consider the usage of data flow constraints in their framework for checking compliance during the whole business process lifecycle.

Some process compliance solutions determine the execution status of each activity by means of explicit notifications by the activity itself. Other solutions try instead to assess the execution status by analyzing the message flow between the business process and the activities, often considering the execution of an activity as a service invocation. Weidlich et al. [10], on the other hand, propose a framework for detecting process execution violations that exploits complex event processing techniques on process data to infer the execution order of process activities.

These solutions address the research questions only partially, since no solution covers all of them. In particular, the support for multiple actors is absent or very

limited: no solution support the definition of processes belonging to multiple actors, the overlapping of different processes having activities in common and, more importantly, concurrent and possibly conflicting constraints on the same activity data defined by different actors.

Concerning the freight transportation domain, during recent years research efforts have been put in developing Smart Container solutions ([11], [12], and [13] just to name a few). However, all these solutions are based on the requirements and business processes of a single stakeholder, and are not thought to promptly react to changes in the involved stakeholders and/or in their business processes, requirements, and data. Such limitations are particularly important for the multimodal transportation, since changes in the involved stakeholders or in the business process definition are frequent and can happen during the shipment enactment phase, thus requiring a proper reconfiguration of the Smart Container.

## 6 Research Methodology

During the PhD, I plan to carry on design and research activities in parallel, as suggested by Wieringa et al [14]. More in detail, the design activity will deal with requirements analysis and definition of a possible solution. The research activity, on the other hand, will deal with the review of the literature to be aware of the state of the art in current technologies and use that as starting point for my work. Research activity will also deal with the validation of the results with respect to case studies to prove their soundness.

Concerning the research methods, for RQ1, RQ3 and RQ4 I plan to follow an experimental research approach. In fact, to validate the solution answering such research questions, I will build a prototype and test it possibly in the real world or in a simulated environment. For RQ2, on the other hand, I plan to follow an empirical research approach. Indeed, I will collect and analyze case studies to better understand requirements on sensor data and, having done this, I will use them as input to properly design a model that addresses all such requirements.

In order to achieve my goals, I plan to structure the research work around the following phases:

1. I will concentrate on answering RQ1 and RQ3 first. The output of this phase will be a process modeling notation that will allow one to model the start and termination of activities, and conditions that violate their execution based on events generated by activity data. I will also propose a methodology for integrating Smart Objects with traditional business processes by generating IoT process models from traditional process definitions, and a tool for modeling processes with the proposed notation.
2. I will then try to answer RQ2 by extending the notation defined in the previous phase, to support the definition of requirements on activity data. The output of this phase will be an extension of the process modeling notation, a BPMS capable of running processes modeled with such notation, and a

prototype of the sensor configuration manager module. The BPMS will also be able to produce a process trace that will allow one to assess process compliance with respect to both process and data flows.

3. I will finally try to answer RQ4 by investigating problems related to the simultaneous execution of multiple business processes having conflicting requirements. The output of this phase will be a prototype of the proposed framework that will support multiple actors and will run on a SBC device.

Currently, the first phase of the research work has started, and I plan to conclude it by the end of 2015. I then plan to start the second phase and conclude it by the fourth quarter of 2016. Finally, I plan to start the third phase and conclude the whole research work by the end of 2017 with the publication of my PhD thesis.

## Acknowledgments

This work has been partially funded by the Italian Project ITS Italy 2020 under the Technological National Clusters program.

## References

1. Haller, S., Magerkurth, C.: The real-time enterprise: Iot-enabled business processes. In: IETF IAB Workshop on Interconnecting Smart Objects with the Internet. (March 2011)
2. Weske, M.: Business Process Management - Concepts, Languages, Architectures, 2nd Edition. Springer (2012)
3. Meyer, S., Ruppen, A., Magerkurth, C.: Internet of things-aware process modeling: Integrating iot devices as business process resources. In: CAISE 2013. LNCS 7908. Springer Berlin Heidelberg (2013) 84–98
4. Thoma, M., Meyer, S., Sperner, K., Meissner, S., Braun, T.: On iot-services: Survey, classification and enterprise integration. In: IEEE GreenCom 2012. (Nov 2012) 257–260
5. Tranquillini, S., Spieß, P., Daniel, F., Karnouskos, S., Casati, F., Oertel, N., Mottola, L., Oppermann, F., Picco, G., Römer, K., Voigt, T.: Process-based design and integration of wireless sensor network applications. In: Proc. BPM 2012, Berlin, Heidelberg, Springer-Verlag (2012) 134–149
6. Schief, M., Kuhn, C., Rsch, P., Stoitsev, T.: Enabling business process integration of iot-events to the benefit of sustainable logistics. Technical report, Darmstadt Technical University (2011)
7. Kharbili, M.E., de Medeiros, A., Stein, S., van der Aalst, W.: Business process compliance checking: Current state and future challenges. In: Modellierung betrieblicher Informationssysteme - Modellierung zwischen SOA und Compliance Management. (Nov 2008) 107–113
8. Awad, A., Weidlich, M., Weske, M.: Specification, verification and explanation of violation for data aware compliance rules. In: Proc. of ICSOC-ServiceWave '09, Berlin, Heidelberg, Springer-Verlag (2009) 500–515

9. Ly, L., Rinderle-Ma, S., Gser, K., Dadam, P.: On enabling integrated process compliance with semantic constraints in process management systems. *Information Systems Frontiers* **14**(2) (2012) 195–219
10. Weidlich, M., Ziekow, H., Mendling, J., Gnther, O., Weske, M., Desai, N.: Event-based monitoring of process execution violations. In: *Business Process Management*. LNCS 6896. Springer Berlin Heidelberg (2011) 182–198
11. Lang, W., Jedermann, R., Mrugala, D., Jabbari, A., Krieg-Bruckner, B., Schill, K.: "the intelligent container" - a cognitive sensor network for transport management. *Sensors Journal, IEEE* **11**(3) (March 2011) 688–698
12. Kim, S.J., Deng, G., Gupta, S., Murphy-Hoye, M.: Intelligent networked containers for enhancing global supply chain security and enabling new commercial value. In: *Intl. Conf. on Comm. Systems Software and Middleware and Workshops*, 2008. (Jan 2008) 662–669
13. Baresi, L., Braga, D., Comuzzi, M., Pacifici, F., Plebani, P.: A service-based infrastructure for advanced logistics. In: *IW-SOSWE Workshop, ESEC/FSE Joint Meeting*, New York, NY, USA, ACM (2007) 47–53
14. Wieringa, R., Heerkens, H.: Design science, engineering science and requirements engineering. In: *RE '08*. 16th IEEE. (Sept 2008) 310–313



# Towards a Framework for Feature Deduplication during Software Product Lines Evolution

Amal Khtira  
(Supervised by Prof. Bouchra El Asri)

IMS Team, SIME Laboratory, ENSIAS, Mohammed V University  
Rabat, Morocco  
amalkhtira@gmail.com

**Abstract.** Software product lines are long-living systems that evolve continuously over time to satisfy the new requirements of customers. This evolution consists of adding or modifying features in the core platform of the product line or in derived products. As a result of this change, many model defects can occur, such as inconsistency and duplication. In this paper, we describe our work which proposes a framework to manage the software product line evolutions. The aim of the framework is to formalize the representation of the software product line models and the specifications of the new evolutions. Then, a set of algorithms are provided which enable the detection of feature duplication.

**Keywords:** Software Product Line; Evolution; Feature Duplication.

## 1 Introduction

The Software Product Line Engineering (SPLE) [1] is an approach that aims at creating individual software applications based on a core platform, while reducing the time-to-market and the cost of development. Many SPLE-related issues have been addressed both by researchers and practitioners, such as variability management, product derivation, reusability, etc. The focus of our work will be on SPL evolution.

The evolution of a SPL involves both changes in the domain model of the product line and the application models of derived products. This evolution consists of adding new features or modifying or deleting existing ones. As a result of these changes, many model defects can arise. In the literature, many papers have dealt with defects such as the incompleteness and inconsistency of features [3], [4], [5] and the non-conformance of constraints [6]. Other papers have dealt with duplication in the code level [7], but few have addressed the problem of features duplication. Our study is different because it aims at finding a solution to the problem of duplication in the feature level, which helps avoid wasting time and effort in implementing duplicate functionalities. Thus, we propose a framework that focuses especially on this specific issue.

Our approach allows, among others, to formalize the representation of the feature models related to software product lines and of the specifications of the new evolutions. Based on the unification of these inputs, a set of algorithms are proposed to enable an efficient detection of features duplication. An automated tool will be developed and its accuracy will be verified incrementally using a case study until we achieve satisfying results.

The rest of the paper is organized as follows. Section 2 positions our approach with related works. In Section 3, we define the research questions and the research goal. In Section 4, we describe the methodology used to carry out our study, namely the DSRM process model. Section 5 explains our approach aiming at detecting duplication when evolving software product lines and presents the progress of our work. Finally, Section 6 concludes the paper.

## 2 Related Work

A plethora of papers have dealt with evolution in software product lines. This evolution concerns either the feature level, the architecture level or the code level. In our approach, we focus especially on features evolution. When evolving the product line or its derived products, some defects can be introduced to the existing models. Several papers in the literature have addressed model defects. For example, Guo and Wang [12] propose to limit the consistency maintenance to the part of the feature model that is affected by the requested change instead of the whole feature model. Romero et al. [5] introduced SPLEmma, a generic evolution framework that enables the validation of controlled SPL evolution by following a Model Driven Engineering approach. This study focused, among others, on SPL consistency during evolution. Mazo [13] defines different verification criteria of the product line model and classifies them into four categories: expressiveness criteria, consistency criteria, error-prone criteria and redundancy-free criteria.

Since the model defects are introduced most of the time from specifications, many studies have dealt with the detection of defects in specifications. For instance, Lami et al. [14] present a methodology and a tool called QuARS (Quality Analyzer for Requirement Specifications) which performs an initial parsing of the specifications in order to detect automatically specific linguistic defects, namely inconsistency, incompleteness and ambiguity. Kamalrudin et al. [15] use the automated tracing tool Marama in order to give the possibility to users to capture their requirements and automatically generate the Essential Use Cases (EUC). This tool supports the inconsistency checking between the textual requirements, the abstract interactions and the EUCs. Holtmann et al. [16] proposed an approach that uses an extended CNL (controlled natural language) from the automotive industry. The CNL requirements are first translated into an ASG (Abstract Syntax Graph) typed by a requirements metamodel. Then, structural patterns are used to allow an automated correction of some requirements errors and the validation of requirements due to new evolutions. A system called CIRCE was introduced by Ambriola and Gervasi [17]. The system pro-

cesses natural language requirements to build semi-formal models in an almost automatic fashion, then checks the consistency of these models and produces functional metric reports. Zowghi [4] provides an evolutionary framework that deals with inconsistency and incompleteness in a way that ensures the correctness of specifications.

An analysis of the literature shows that the majority of studies deal with inconsistency, while the problem of feature duplication has not been thoroughly treated. In addition, these studies focus either on the detection of defects in feature models or in specifications, but do not address the comparison between the new features and the existing ones to avoid the introduction of defects into the SPL.

### 3 Research Questions and Research Goal

Feature Duplication is among the defects that can be introduced into the model during software product lines evolution. According to [18], this defect occurs due to many reasons, such as mistakes in the design, the non-synchronization between the different people working on the project, the rapid implementation of requirements without referring to the existing models, etc. In the purpose of solving this problem, we need to answer the following research questions:

- How can we define feature duplication?
- How to detect feature duplication when evolving software product lines?
- How can we avoid the introduction of duplication in the SPL?

When evolving a software product line, the duplication of features must be verified in three levels: in the feature models (domain model and application models), in the specification of the new evolution, and between the feature models and the specification. Thus, other specific research sub-questions have to be answered:

- How can we formalize the representation of the feature models and the natural language specifications in order to facilitate the deduplication process?
- How can we detect feature duplication between the new specifications and the existing feature models?
- How to avoid the introduction of duplicate features from specifications to the existing models of software product lines?

Based on the research questions, the goal of our work is to construct:

*“A framework that aims at formalizing and unifying the representation of the SPL feature models and the specifications of new evolutions, detecting duplicate features, and generating duplication-free specifications. To enable an automatic deduplication, a tool will be developed based on the proposed framework.”*

## 4 Research Methodology

In our study, we adopt a design science approach in IS. The purpose of design science as stated by Hevner et al. [19] is to build and evaluate IT artifacts designed to solve identified business problems. In order to structure our work, we use the Design Science Research Methodology (DSRM) process model proposed by Peffers et al. [20]. It is a sequential process based on six main activities: Problem identification and motivation, Definition of objectives for the solution, Design and development, Demonstration, Evaluation and Communication. Figure 1 illustrates the customized steps of the adopted process.

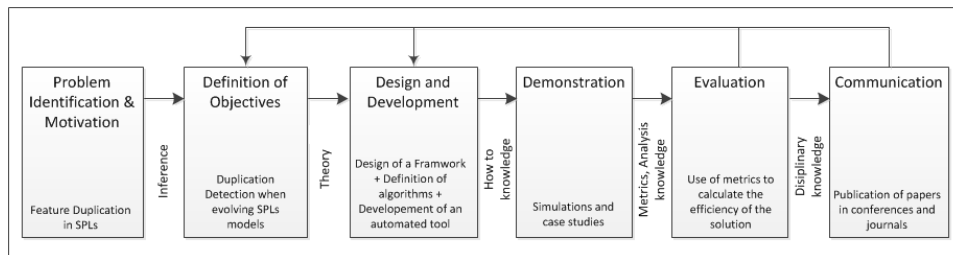

Figure 1. The DSRM process model applied to our research (adapted from [20]).

In the rest of this section, we describe the details of each of the process steps.

### 4.1 Problem Identification and Motivation

The introduction of new features into the domain and application models of a software product line can be the source of many model defects (e. g. inconsistency, incorrectness, incompleteness, redundancy). A review of the literature has shown that these defects have been treated by several studies, while little attention has been given to the problem of feature duplication.

The main objectives of a software product line are the reduction of time-to-market, the reduction of cost, and the improvement of product quality. The introduction of duplication in a SPL prevents from meeting these objectives, because it causes a waste of time, money and effort by implementing the same functionalities many times. In addition, duplicate features can change independently from each other, which may cause inconsistencies in the model. For example, a feature can be deleted or modified while its copy in another place remains the same, which leads to a contradiction. Moreover, duplication in the feature level impacts the quality of the product by causing the famous problem of code cloning, resulting in the recurring-bug problem and the increase of the maintenance effort [21]. A solution is thus necessary to detect duplicate features in the first step of an evolution, which is requirements analysis, which helps avoid their inclusion into the existing models from the very beginning.

## 4.2 Definition of Objectives for the Solution

The objective of our solution is to detect feature duplication between the existing feature models and the new specifications related to a software product line evolution. To achieve this, our artifact has two main concerns. First, the artifact must allow the formalization of the feature models and the specifications in order to facilitate the verification of defects. The second concern of the artifact is to detect and remove duplicate features by providing a set of algorithms.

## 4.3 Design and Development

This step consists of designing and building the artifact. Hence, we define in details the basic framework of our approach, which should meet the objectives set during the previous stage. The first action is thus to identify a method and select tools to formalize the representation of the framework inputs. The second action consists of defining a set of algorithms to detect duplication in the level of specifications, in the level of feature models, then between the specifications and the SPL models. Since manual verification has proved to be time-consuming and error prone, a tool is to be developed based on the framework in order to automatize the two actions.

## 4.4 Demonstration

To demonstrate the efficacy of our solution, we will use a case study from the CRM (Customer Relationship Management) field. Indeed, a CRM project has to follow continuously the market change at the lowest possible cost and satisfy new requirements of customers on tight deadlines. Consequently, an optimization of the requirements implementation is necessary, which requires an efficient verification of the model defects, especially duplication. Thus, we take the feature model of the CRM and the textual specifications of a new evolution as inputs of the automated tool. In the first place, the two inputs have to be formalized and unified. Then, the algorithms of deduplication are applied to detect and remove the duplicate features.

## 4.5 Evaluation

After the development of the artifact, an iterative evaluation is necessary to determine how effective it is. This evaluation is carried out using some metrics such as *the number of detected duplications in a specification*, or *the percentage of duplicate features between a specification and a feature model*. To decide whether the results generated by the artifact are satisfying or not, we define the required values of the proposed metrics in agreement with the customer.

## 4.6 Communication

The identified problem and the proposed artifact are communicated to researchers through several publications in conferences and journals. Hitherto, we published a first paper in the proceeding of the ICSEA 2014 Conference [8], in which we defined duplication and proposed a first design of the framework and the formalization of the basic concepts of our solution. An extended version of this paper is under review [9]. Two other papers on the same subject are under publication [10], [11]. In [10], we deal with the duplication detection in the specifications of new evolutions, while in [11] we address the duplication between the specifications and the existing feature models. As this work progresses, we intend to publish other papers to communicate the new results.

## 5 Proposed Approach and Work Progress

To deal with the problem of duplication in software product lines, we propose an approach based on a two-process framework. The first process consists of formalizing and unifying the representation of the SPL models and the specifications of an evolution. The second process involves the detection and removal of duplicated features caused by the new evolution. Figure 2 represents the proposed framework.

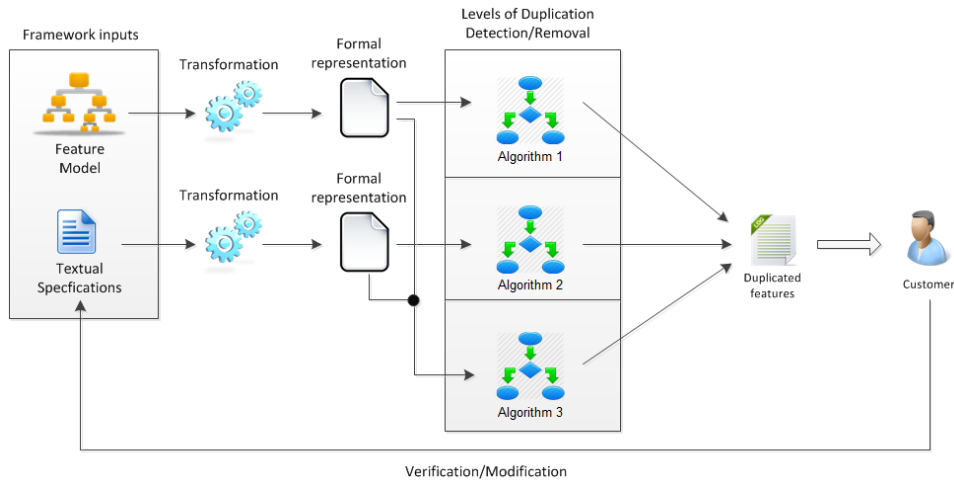

Figure 2. The Overview of the Framework.

During the domain engineering of a software product line, the common and variant features of all the specific applications are captured. To document and model variability, many approaches have been proposed. For instance, [2] introduced the orthogonal variability model which defines variability in a separate

way. Salinesi et al. [22] used a constraint-based product line language. Other approaches proposed to model variability using UML models or feature models (FODA [23]). In our study, we opt for the FODA method used by the Feature-oriented software development (FOSD) paradigm [24] whose objective is to generate automatically software products based on the feature models. Hence, tools such as FeatureIDE [25] have been proposed to formalize the representation of feature models and enable the automatic selection of features of derived products. This tool will be used during the first process of our framework.

During the evolution of a derived product, the requirements are most of the time expressed in the form of natural language specifications. This form of presentation makes it difficult to detect the different defects that can occur (Duplication in our case). To deal with this problem, the solution is to transform natural language specifications into formal or semi-formal specifications. For this, we adopt a Natural Language Processing (NLP) approach. NLP is a technology of computer science whose objective is to process sentences in a natural language such as English and to build output based on the rules of a target language understandable by the machine. In our study, the purpose is to transform specifications into the same format of the SPL feature models by using syntax and semantic parsers. The syntax parser analyzes the specifications and generates the syntactic tree based on the English grammar, while the semantic parser extracts the meaning of the sentences. The operation of parsing will be performed using the OpenNLP library [26], which is a machine learning based toolkit for the processing of natural language text.

The second process of the framework consists of applying a set of algorithms of search and comparison to detect duplications in the processed specifications, feature models and between these two inputs. To help define the algorithms, we need to express mathematically the different concepts of the framework.

So far, we have identified the processes of the framework and its basic concepts [8], [9]. We have started the definition of the algorithms of duplication detection in the specifications [10], and between the specifications and the feature models [11]. In future work, we intend to implement our approach by designing an automated tool that takes as inputs the domain feature model of a SPL, the application feature model of a derived product and the specification of an evolution. The output generated by this tool is the list of duplicate features in these inputs and those caused by the evolution. This output will be sent to the customer to verify his initial needs and change them if necessary.

## 6 Conclusion

This paper contains an overview of our thesis dealing with software product line evolution. After a review of the existing approaches concerning the detection of model defects when evolving SPLs, we decided to focus on the resolution of a specific problem, which is feature duplication. The objective of this study is to construct a framework that helps detect and remove duplicate features introduced by new evolutions. An automated tool is to be developed to avoid

the complexity of manual verification. The evaluation of the artifact will be performed by applying it to a case study from the CRM field.

## References

1. P. Clements and L. Northop, *Software Product Lines - Practices and Patterns*, Boston: Addison-Wesley, 2002.
2. K. Pohl, G. Böckle, and F. Van Der Linden, *Software Product Line Engineering Foundations, Principles, and Techniques*, Berlin, Germany: Springer-Verlag, 2005.
3. A. Reder and A. Egyed, "Determining the cause of a design model inconsistency," *IEEE Transactions on Software Engineering*, vol. 39, no. 11, pp. 1531-1548, 2013.
4. D. Zowghi and V. Gervasi, "On the interplay between consistency, completeness, and correctness in requirements evolution," *Information and Software Technology*, vol. 46, no. 11, pp. 763-779, 2004.
5. D. Romero, S. Urli, C. Quinton, M. Blay-Fornarino, P. Collet, L. Duchien, and S. Mosser, "SPLEMMMA: a generic framework for controlled-evolution of software product lines," in *Proc. 17th International Software Product Line Conference co-located workshops*, ACM, 2013, pp. 59-66.
6. R. Mazo, R. E. Lopez-Herrejon, C. Salinesi, D. Diaz and A. Egyed, "Conformance checking with constraint logic programming: The case of feature models," in *Proc. COMPSAC'11*, IEEE, 2011, pp. 456-465.
7. S. Schulze, "Analysis and removal of code clones in software product lines," *Doctoral dissertation*, Magdeburg, Universitt, Diss., 2013.
8. A. Khtira, A. Benlarabi, B. El Asri, "Towards Duplication-Free Feature Models when Evolving Software Product Lines," in *Proc. 9th International Conference on Software Engineering Advances (ICSEA'14)*, Oct. 2014, pp. 107-113.
9. A. Khtira, A. Benlarabi, B. El Asri, "A Framework for Ensuring Duplication-Free Feature Models when Evolving Software Product Lines," *Submitted for publication to "International Journal On Advances in Software", under review.*
10. A. Khtira, A. Benlarabi, B. El Asri, "Detecting Feature Duplication in Natural Language Specifications when Evolving Software Product Lines," *Accepted in the 10th International Conference on Evaluation of Novel Approaches to Software Engineering (ENASE'15), under publication.*
11. A. Khtira, A. Benlarabi, B. El Asri, "An Approach to Detect Duplication in Software Product Lines Using Natural Language Processing," *Accepted in the Mediterranean Conference on Information and Communication Technologies (MEDICT'15), under publication.*
12. J. Guo and Y. Wang, "Towards consistent evolution of feature models," In. *Software Product Lines: Going Beyond*, Springer Berlin Heidelberg, 2010, pp. 451-455.
13. R. Mazo, "A generic approach for automated verification of product line models," *Ph.D. thesis*, Pantheon-Sorbonne University, 2011.
14. G. Lami, S. Gnesi, F. Fabbrini, M. Fusani, and G. Trentanni, "An automatic tool for the analysis of natural language requirements," *Informe tecnico*, CNR Information Science and Technology Institute, Pisa, Italia, Sept. 2004.
15. M. Kamalrudin, J. Grundy, and J. Hosking, "Managing consistency between textual requirements, abstract interactions and Essential Use Cases," in *Proc. COMPSAC'10*, IEEE, July 2010, pp. 327-336.
16. J. Holtmann, J. Meyer, and M. von Detten, "Automatic validation and correction of formalized, textual requirements," in *Proc. 4th International Conference on Software*



- Testing, Verification and Validation Workshops (ICSTW), IEEE, Mar. 2011, pp. 486-495.
17. V. Ambriola and V. Gervasi, "Processing Natural Language Requirements," in Proc. 12th IEEE Conference on Automated Software Engineering (ASE'97), IEEE Computer Society Press, Nov. 1997, pp. 36-45.
  18. A. Hunt and D. Thomas, *The pragmatic programmer: from journeyman to master*, Addison-Wesley Professional, 2000.
  19. A. R. Hevner, S. T. March, J. Park, and R. Sudha, "Design science in information systems research," *MIS quarterly*, vol. 28, no. 1, pp. 75-105, 2004.
  20. K. Peffers, T. Tuunanen, A. M. Rothenberger, and S. Chatterjee, "A design science research methodology for information systems research," *Journal of management information systems*, vol. 24, no. 3, pp. 45-77, 2007.
  21. L. Aversano, L. Cerulo, and M. Di Penta, "How clones are maintained: An empirical study," 11th European Conference on Software Maintenance and Reengineering (CSMR'07), IEEE, 2007.
  22. C. Salinesi, R. Mazo, O. Djebbi, D. Diaz, and A. Lora-Michiels, "Constraints: the Core of Product Line Engineering," In. RCIS11, IEEE, Guadeloupe- French West Indies, France, May 19-21, 2011, pp. 1-10.
  23. K. Kang, S. Cohen, J. Hess, W. Novak, and S. Peterson, "Feature-Oriented Domain Analysis (FODA) Feasibility Study," Technical Report CMU/SEI-90-TR-21, Carnegie Mellon University, Software Engineering Institute, Nov. 1990.
  24. S. Apel and C. Kästner, "An Overview of Feature-Oriented Software Development," *Journal of Object Technology (JOT)*, vol. 8, pp. 49-84, 2009.
  25. C. Kästner, T. Thüm, G. Saake, J. Feigenspan, T. Leich, F. Wielgorz, and S. Apel, "FeatureIDE: A Tool Framework for Feature-Oriented Software Development," in Proc. The 31st International Conference on Software Engineering, 2009, pp. 611-614.
  26. The Apache Software Foundation, "OpenNLP," [opennlp.apache.org](http://opennlp.apache.org).

# Safe Management of Software Configuration

Markus Raab

Vienna University of Technology  
Institute of Computer Languages, Austria  
`markus.raab@complang.tuwien.ac.at`  
Supervisor: Franz Puntigam

**Abstract.** We tend to write software in a parameterized way with parameter values specified in configuration files. Such configurability allows us to deploy software in a context not initially thought of, but it also has the downside that it introduces a new class of hard-to-track faults. This issue arises because the use of configurations in programs is not integrated into configuration management needed by administrators. We propose a light-weight specification language to be used by both parties. From this specification we generate configuration access code that includes compile-time checks. Furthermore, we use the same specification to add run-time checks for safe configuration management. We expect that our approach averts many failures configurable software faces today. Additionally, we think it improves the quality altogether, because the documentation resulting from the specification leads to a better understanding of the overall system.

## 1 Introduction

Today many behavioral aspects of applications are not fixed at compile-time, but are determined at run-time by examining configuration files, environment variables, and command-line arguments. Even for an average software system the configurability is complicated due to a huge number of possibilities, constraints and dependencies.

As studies revealed [8], [13] much time and money is wasted because of configuration errors. Misconfigurations are one of today's major causes of system failures. Faulty configuration files sometimes trigger crashes and make services unavailable. These problems lead to downtimes, severe outages and a frustrating process of debugging configuration problems.

The state of the art in software configuration is to use schemata to describe the data in the *key databases* (they facilitate access to software configuration) and type systems to describe the corresponding variables in the programming languages. These two worlds are disconnected. We think that this gap causes most of these failures.

A recent paper supports our view and argues that users are not the ones to blame for misconfiguration [12]. The authors found evidence that the data-flow path from variable initialization to variable use contains many potential

errors. We think that these errors are only the symptom of the state-of-the-art development. We are positive that consequent use of a software configuration specification mitigates these issues.

In the thesis discussed in this paper we design and study a novel specification language and its integration in a key database. The specification should include constraints for both the key database and the variables in order to achieve following benefits and goals:

- Provide safe use of variables within programming languages containing values of configuration files by exploiting compile-time checks using type systems.
- Adding run-time checkers when compile-time checking is not possible, e.g. for managing the key databases.
- From the specification other artifacts can be derived, yielding improvement compared to state-of-the-art systems. E.g., in PostgreSQL<sup>1</sup> 5 artifacts needs to be maintained in the software engineering process.

The specification facilitates code generation in the programming languages used by the applications. When the application and the generated code is compiled, compile-time checks detect many problems at an early stage. The specification allows software architects, developers and end-users to have a better understanding of software configuration, e.g., it deals with documentation and improves traceability. So the specification can even lead to an entirely better software system.

For example, the OpenLDAP 2.4.39 daemon crashes when “listener-threads” is configured to be larger than 15 [12]. The documentation for this configuration item does not even mention this limit nor that these values are internally changed to be a power of 2. In our approach we solve this issue by writing a specification:

```
[/openldap/listener-threads]
type=enum 1 2 4 8
```

We have the identifier `/openldap/listener-threads` and one *property* `type`. Because of this property, we know which values are permitted. When the user changes the value of “listener-threads” to 16, the key database tells him/her that 16 is not one of the allowed values 1, 2, 4 or 8. Using this specification OpenLDAP would not crash and the difficult process of debugging is avoided. For a developer the approach is intuitive: configuration items can be used like variables, e.g., the following C++ code prints the value of the configuration item:

```
std::cout << openldap.listener-threads << std::endl;
```

The library *libelektra* provides access to the key database. The code generator *genelektra* makes sure that configuration items used by the developer always match with the specifications. We also generate documentation that includes the type information from the specification. Any other property in addition to `type` can be added, which means the specification is extensible.

<sup>1</sup> Version 9.1.12, see [http://doxygen.postgresql.org/guc\\_8c\\_source.html](http://doxygen.postgresql.org/guc_8c_source.html)

We expect, given powerful properties in the specification, it is simple to write a specification that avoids crashes, because 90% of all options are covered with a dozen types [8]. Using this approach, mismatches are ruled out and faulty use of the variable is detected by the compiler. The substantial gain is that it enhances type safety without leaving the familiar programming environment. Other potential benefits of our approach are improved software maintenance and evolution as well as reduced duplication of code.

The rest of the paper is structured as follows: Section 2 describes the details of our approach. In Section 3 we show how we plan to validate or falsify our research questions. In Section 4 we talk about expected results based on our current knowledge. Finally, in Section 5 we compare our approach to related work before drawing our conclusions in Section 6.

## 2 Elektra

Our approach, called *Elektra*, introduces a specification for configuration. Instead of many places containing constraints and types, Elektra defines a clear way how to specify configuration. The key database *libelektra* enforces the constraints at run-time and a code generator *genelektra* ensures program code conforms to it.

The approach is still in its infancy and thus many vital questions are not yet answered. The aim of our thesis is to answer following question: **What kind of influence has the use of our configuration specification framework, i.e. Elektra, on software?** The two subquestions, to solve or at least alleviate the problems stated in Section 1, are:

1. Which properties in the specification have the strongest influence on avoiding software failures caused by invalid configuration files?
2. How does the specification interact during software engineering processes with software architectures, software evolution, and software quality?

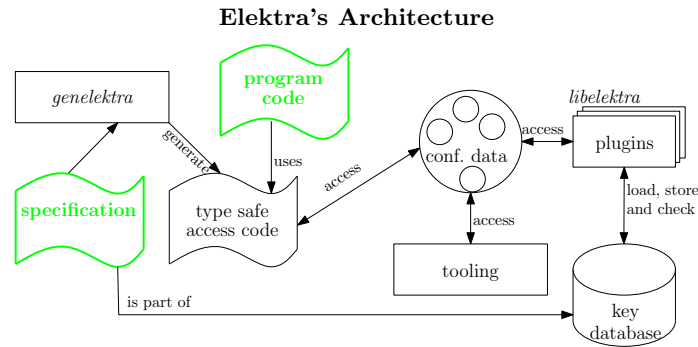

**Fig. 1.** Boxes represent software artifacts. The **bold** boxes show artifacts developers need to implement. Our *Elektra* implementation provides the other libraries and tools.

In Fig. 1 we see how to apply our approach and which artifacts it consists of. We immediately spot the configuration data structure in the center. It contains

all key/value pairs representing configuration items. As used in every configuration parser they form a generic, but unsafe, container. In our approach we pass it around between tools, plugins and the type safe access code to avoid tight coupling between these components.

## 2.1 Key Database

The *key database* is responsible for retrieval and storage of configuration items. We inherit Elektra’s key database and plugin system from our earlier work [5]. Configuration is retrieved and stored using different plugins. While some of the plugins are responsible for the obvious tasks, e.g. parsing configuration files, others take care of cross-cutting concerns or implement run-time checkers. Latter plugins use the specification as input and perform run-time checks and validate input before it is stored in the key database.

## 2.2 Specification

As we see in Fig. 1 the *specification* is deployed as part of the key database. By including the specification in the key database, we build up an information system which supports administrators in the process of creating correct software configuration. Constraints, types and links support administrators in this process. The specification states how a valid configuration is structured and which values are permitted.

For our thesis we are particularly interested in specification validation. The specification validation needs to fulfill the following tasks:

1. Check if the specification is consistently typed and has no conflicting constraints.
2. Compile a minimal list of plugins that can perform the run-time checks.
3. Check if the plugins will work together. For run-time checkers it is known that such a check is a non-trivial task.
4. Check if the specification has a safe upgrade path from its previous version.
5. Ensure that the particular configuration file (syntax and structure) works with this specification by checking if they have a common supertype.

## 2.3 Code Generation

The *code generator* is used to generate all other configuration-related artifacts from the specification. We are especially interested in the generation of *type safe access code*. In earlier work, context awareness turned out to be useful to provide a type safe access code using C++ [6], [7]. The types used in the specification must be mapped to types or generated classes within programming languages for code generation.

The compile-time safety of the approach stems from the fact that no identifier string nor self written type conversions exist in the application’s source code. Instead, the developer prefers to use generated variables. Without our approach, file names and other identifiers usually exist as strings in the code.

### 3 Validation & Methods

The scientific foundation and starting point of our research is in the area of modularity [5]. To validate our first question, i.e. which properties have the strongest influence, we first must find out which properties are good choices for our problem domain and need an implementation of them. The following *run-time checkers* are candidates as properties in the specification:

- structure validation with CORBA data types (as shown in our thesis [5]),
- more powerful data types, e.g. units of measurement,
- novel ways to define subtyping,
- types inference using unification,
- global constraints, e.g. using Gecode, Coinor and Z3,
- schemas, e.g. Relax NG Schema and XSD,
- Data Format Description Languages,
- configuration value deduction and
- any combination of the approaches above.

With the described tooling and an implementation of run-time checkers the validation of the first question in Section 2 is straight forward:

1. By analyzing real-world problems we find out which kinds of typical and sophisticated configuration errors occur in practice, e.g.:
  - (a) Typos (e.g. insertion, substitution, transposition),
  - (b) Structural errors (e.g. missing sections, parameters in wrong sections),
  - (c) Semantic errors (e.g. wrong version, documentation, confusing similar applications) and
  - (d) Domain-specific errors (e.g. no such resource)
2. We build a model [3] that allows us to construct such configuration errors.
3. We build a run-time checker that permits us to reject erroneous configuration based on a promising technique, i.e., one of those listed above.
4. We evaluate the run-time checker, e.g., by comparing the expressiveness and usability of the specification.

The question of the influence during software development asked in Section 2 is much more challenging, because it involves user studies. Case studies of individual attempts can provide valuable insight. The following validation plan is even more precious:

1. We create an assignment (a list of requirements) that is specifically designed to have a non-trivial, but not too complex configuration. To reduce the effort for the participants, we implement most parts of the application, except of the configuration relevant parts.
2. We train *all* participants how to use our approach. The explanation includes how to write the specification.
3. We randomly choose two groups A and B out of the participants:
  - (a) Group A solves the task by using a specification (with the best checkers from the previous validation step present).

- (b) Group B solves the task without a specification.
- 4. During the development we make snapshots of the work. Each snapshot will be tested by injection of erroneous configuration and running unit tests.
- 5. Finally, the participant fills out a questionnaire to answer the usefulness of the specification and checkers on a Likert scale.

Using this method, we can answer the questions if there is a difference between group A and B regarding:

1. The needed efforts.
2. Which applications are more safe.
3. If the participants think the specification was useful.

We identified following risks and threads to validity:

1. The selection of participants might be biased.
2. The participants may not have many years of experience and their learning curve might not be representative.
3. When we teach the specification we might give a group an unfair advantage.
4. The number of participants might be too small to give results beyond the group.

To mitigate these issue we add graduates and employees to our pool. Additionally, we will use case studies and benchmarks to show other properties.

## 4 Expected Results

### 4.1 Performance

In previous work [7], we showed that the access of the variables representing the configuration values does not impact performance compared to the use of native variables. Because many applications use strings at run-time, we expect that applications will even benefit from our approach in respect of run-time. For initial startup we expect that only a reasonable overhead will be added. Some additional startup time compared to hard-coded solutions, however, is unavoidable because of the abstraction Elektra provides: no configuration file names are fixed at compile-time and a generic container is used.

### 4.2 Specification

We expect that the specification will present a powerful way to precisely define all influencing parts of the software configuration. We also think that the quality of documentation will rise as a result of less duplication. The properties of the specification, that includes type information, will give valuable hints often not available in today's systems. More assumptions will be stated explicitly.

We expect the availability of the specification in the key database to play a crucial role for interoperability: It will allow us to facilitate validation on every access, even by applications not aware of a specific specification.

Moreover the specification will allow us to add traceability links to architectural decisions [2]. As a result, we expect our approach to improve the traceability and decision making process.

### 4.3 Safety

Type safety means that a system prevents certain kinds of errors. Because of the additional compile-time and run-time checks, we expect applications using our approach to be safer in respect to the problems mentioned in Section 1. We think that most problems can be solved by adding a minimal amount of properties in the specification. For some issues, more effort will be required from the developers.

### 4.4 Less Effort

We expect that a key database with integrated specification will make it easier for administrators to make the right decisions in shorter time. We also think that validation sometimes even will avoid the necessity of debugging configuration problems.

The integration with the key database will allow us to change many configuration items in a safe way across applications without manual intervention. We expect this property to have a similar effect as has the use of DNS names instead of IP addresses.

## 5 Related Work

Currently, to the best of our knowledge, no other approach permits us to specify configuration independent of the used technology (e.g. XSD works with XML). Configuration parsers (e.g. Apache commons configuration) need the specification of configuration data additional to the specification of configuration variables. They do not detect mismatches between code accessing configuration and the schemata of the data. We conclude the use of these libraries leads to all issues described in Section 1. Moreover, they do not provide means to abstract over file location and syntax, but need this information hard-coded.

Pluggable types [4] tackle some issues mandatory type systems have and are still an active research topic. These type systems are both used for popular dynamic and static programming languages, but are currently not available for specification of software configuration systems.

ConfErr [3] is able to detect configuration errors by injecting wrong configurations before starting the application. The main difference to our approach is, that ConfErr does not use a specification. We cannot directly extend ConfErr for our benchmarks because it uses an internal representation which does not support all configuration standards Elektra supports.

Range Fixes [11] make use of constraints in order to support the administrator in the decision making process, but the authors did not tackle the problem of wrong use of configuration items in the code of applications.

AutoBash [9] and ConfAid [1] have similar goals as Elektra. In these approaches predicates, that test the application, must be available on the productive system. We think that testing should not happen on the productive system,



but instead earlier in the software engineering process. In our approach, possible problems will be ruled out by the specification so that they cannot occur in the productive system.

Spex [12] can infer parts of the specification by analyzing the code. This approach is complementing our approach in the sense that it can be used for initial construction of the specification for legacy code. It is, however, not suitable for a software engineering process. Even though Spex is the best tool available at the moment, it can only detect less than 40% of bad reactions. Because in our approach constraints are explicitly defined in the specification, the number is expected to be much higher, only limited by mistakes in the specification.

Software product lines often assume that different products have different deliveries. In our approach, the same binary can be used in different deployments. In approaches that delay variability up to the execution of the application [10] our work complements product lines by increasing safety on configuration changes.

## 6 Conclusion

In this paper we discussed further directions of a thesis with the objective to improve integration and safety of key databases. We propose a simple configuration specification language that is only data integrated in a key database. The specification provides support for administrators configuring the system. Additionally, the specification allows us to synthesize code in order to eliminate potential incorrect use of configuration items in the application.

So far, we have achieved:

1. A fully working key database [5] with several dozens of plugins to support many configuration file standards and to provide some run-time checkers.
2. A fully working code synthesis tool [7] with support for thread-local and global context awareness for embedded systems [6].
3. No overhead when reading configuration items [7].
4. An implementation of Elektra (see <http://www.libelektra.org>) is freely available and can be used to see current progress of our work. Elektra already includes all components as shown in Fig. 1.

These contributions are significant, because they lead to a specification language for code synthesis and run-time checkers that mitigate the issues as mentioned in Section 1. They are also practically relevant, because they provide stakeholders a good understanding of their system's configurability and might even reduce crashes and downtime.

In the next steps we will:

1. further define a specification language and its properties,
2. implement tooling to verify specifications and configurations (run-time and compile-time checkers), and
3. conduct the implementation and study as outlined in Section 3.

## References

1. Attariyan, M., Flinn, J.: Automating configuration troubleshooting with dynamic information flow analysis. In: Proceedings of the 9th USENIX Conference on Operating Systems Design and Implementation. pp. 1–11. OSDI’10, USENIX Association, Berkeley, CA, USA (2010)
2. Harrison, N.B., Avgeriou, P., Zdun, U.: Using patterns to capture architectural decisions. *Software*, IEEE 24(4), 38–45 (2007)
3. Keller, L., Upadhyaya, P., Candea, G.: Conferr: A tool for assessing resilience to human configuration errors. In: Dependable Systems and Networks With FTCS and DCC, 2008. pp. 157–166. IEEE (2008)
4. Papi, M.M., Ali, M., Correa Jr, T.L., Perkins, J.H., Ernst, M.D.: Practical plug-gable types for java. In: Proceedings of the 2008 international symposium on Software testing and analysis. pp. 201–212. ACM (2008)
5. Raab, M.: A modular approach to configuration storage. Master’s thesis, Vienna University of Technology (2010)
6. Raab, M.: Global and thread-local activation of contextual program execution environments. In: Proceedings of 11th International IEEE/IFIP Workshop on Software Technologies for Future Embedded and Ubiquitous Systems. pp. 1–8. IEEE (2015)
7. Raab, M., Puntigam, F.: Program execution environments as contextual values. In: Proceedings of 6th International Workshop on Context-Oriented Programming. pp. 8:1–8:6. ACM, NY, USA (2014), <http://doi.acm.org/10.1145/2637066.2637074>
8. Rabkin, A., Katz, R.: Static extraction of program configuration options. In: Software Engineering (ICSE), 2011 33rd International Conference on. pp. 131–140. IEEE (2011)
9. Su, Y.Y., Attariyan, M., Flinn, J.: Autobash: improving configuration management with operating system causality analysis. *ACM SIGOPS Operating Systems Review* 41(6), 237–250 (2007)
10. Van Gurp, J., Bosch, J., Svahnberg, M.: On the notion of variability in software product lines. In: Software Architecture, 2001. Proceedings. Working IEEE/IFIP Conference on. pp. 45–54. IEEE (2001)
11. Xiong, Y., Hubaux, A., She, S., Czarnecki, K.: Generating range fixes for software configuration. In: Proceedings of the 34th International Conference on Software Engineering. pp. 58–68. ICSE ’12, IEEE Press, Piscataway, NJ, USA (2012), <http://dl.acm.org/citation.cfm?id=2337223.2337231>
12. Xu, T., Zhang, J., Huang, P., Zheng, J., Sheng, T., Yuan, D., Zhou, Y., Pasupathy, S.: Do not blame users for misconfigurations. In: Proceedings of the Twenty-Fourth ACM Symposium on Operating Systems Principles. pp. 244–259. ACM (2013)
13. Yin, Z., Ma, X., Zheng, J., Zhou, Y., Bairavasundaram, L.N., Pasupathy, S.: An empirical study on configuration errors in commercial and open source systems. In: Proceedings of the Twenty-Third ACM Symposium on Operating Systems Principles. pp. 159–172. SOSP ’11, ACM, New York, NY, USA (2011)

## Author Index

### **K**

Khtira, Amal	65
Kraljić, Adnan	28

### **M**

Masse, Pierre-Aymeric	47
Meroni, Giovanni	56
Mertens, Steven	10
Mrasek, Richard	1

### **P**

Peng, Xuesong	39
Petrevska Nechkoska, Renata	19

### **R**

Raab, Markus	74
--------------	----