

# Theoretical And Practical Basics of Creating a Virtual Microcontroller System of Relay Power Supply of The Heating Element

Alexandr Zasornov<sup>a</sup>, Iryna Zasornova<sup>a</sup>, Kira Bobrovnikova<sup>a</sup> and Viktoriia Buzył<sup>b</sup>

<sup>a</sup> Khmelnytskyi National University, Instytutska str., 11, Khmelnytskyi, 29016, Ukraine

<sup>b</sup> Ruby Play Company, Elite Business Centre, Trejqa ta Box Box Msida, MSD 1840, Malta

## Abstract

Today, the issue of the economical use of energy sources is actual in the world, because of their significant price increase. Users should choose the heating method and system that is most effective in terms of safety, components costs, installation and commissioning, ergonomics, etc. Electric heating systems meet all these requirements. Despite the wide selection of modern heating elements, working with them is impossible without using a heating control system. All heating element systems are controlled by measuring the temperature of the coolant or the surface of the heating element. The high thermal inertia of the heating element makes it difficult to maintain the thermal regime. Knowing the main shortcomings of heating element control systems, it is proposed to create a virtual microcontroller system for the relay power supply of the heating element. This can be achieved by using a microcontroller for control, which will be able to evaluate the information and generate control pulses to turn on the DC source. This method of controlling the heating element will be carried out programmatically, without human intervention. For the development of a virtual microcontroller relay power system, theoretical foundations have been developed that take into account the capabilities of the experimental setup. To check the adequacy of the modeling, a comparison of the processes of heating (cooling) the heating element and charging (discharging) the capacitor was performed. A block diagram of the simulation program of two complete heating and cooling circulations has been developed. To check the operation of the virtual microcontroller system of the relay power supply of the heating element, the following was performed: simulation of two circulations of complete heating and cooling on an experimental installation; simulation of a gradual decrease in the temperature of the heater with three control pulses. Ways of further research are planned.

## Keywords <sup>1</sup>

Modeling, programming, microcontroller, temperature, heating, cooling, electric heating element

## 1. Introduction

Currently, in connection with the significant increase in the price of the main energy sources – electricity, natural and liquefied gas, and diesel fuel – users must choose a heating method and system that is the most effective from the point of view of safety, component costs, installation and

---

IntelliTSIS'2023: 4th International Workshop on Intelligent Information Technologies and Systems of Information Security, March 22–24, 2023, Khmelnytskyi, Ukraine

EMAIL: azasornov@gmail.com (A. Zasornov); izaronova@gmail.com (I. Zasornova); bobrovnikova.kira@gmail.com (K. Bobrovnikova); vika.ab53@gmail.com (V. Buzył)

ORCID: 0000-0002-9387-6997 (A. Zasornov); 0000-0001-6655-5023 (I. Zasornova); 0000-0002-1046-893X (K. Bobrovnikova); 0000-0003-0072-2321 (V. Buzył)



© 2023 Copyright for this paper by its authors.  
Use permitted under Creative Commons License Attribution 4.0 International (CC BY 4.0).  
CEUR Workshop Proceedings (CEUR-WS.org)

commissioning, ergonomics, availability on the market, controllability, the possibility of autonomous operation, etc. [1–5]. Electric heating systems meet all these requirements.

## 2. Literature Review

Today there is a need for microcontroller relay power supply systems (MRPS) heating elements. There are MRPS that are used in everyday life and production and those that are in a state of scientific development. Therefore, quite a lot of scientific works related to the consideration of this issue have been published. We will consider only those that characterize different approaches to its solution [6–13]. The paper [6] describes a fast and high-precision MRPS using a proportional integral derivative (PID) and a control method using an STM32 microcontroller. In [7], an open-loop MRPS with an alternative solution is described, which is not based on temperature control but works as a periodic timer to manipulate the switching of the heating element voltage. The project [8] uses an embedded system with an ATMEGA 328p microprocessor, temperature, and humidity sensors and a Wi-Fi module for monitoring and maintaining the necessary parameters. In [9], a smart and low-cost temperature monitoring and control system is proposed, which combines a DHT22 sensor to detect the ambient temperature and humidity and a NodeMCU as the main microcontroller for control. In [10], temperature values are determined by a DHT22 sensor and processed by an Arduino-based microcontroller, which has a built-in PID control program, the output of which controls the heaters. Work [11] describes the MRPS, which controls and monitors temperature and other parameters with the help of a network of intelligent sensors using developed hardware and software. In the article [12], an automatic temperature control system is designed using a DHT11 sensor and Arduino. The user can set the minimum and maximum reference temperatures from the keyboard. The DHT11 sensor detects the temperature of the surrounding room and displays the result in degrees Celsius on the liquid crystal display (LCD). In the article [13], a control system using fuzzy logic was investigated. The use of fuzzy logic allows the control to ensure the appropriate temperature and comfortable heat distribution with low energy requirements. Despite the different approaches to the study and implementation of MRPS [6–13], none of the above uses the process of modeling the action of the external environment to study and choose the optimal control method. Most of these systems are quite expensive and require highly skilled reprogrammers to operate.

## 3. Analysis of modern electric heating systems

Although there are a large number of electric heating systems, there are common requirements for the heating elements used in them. Designs of heating elements differ in the material from which it is made and the features of the manufacturing process, etc. [14]. However, the materials used for the manufacture of heating elements must have high specific electrical resistance and a low-temperature coefficient of specific resistance. In addition, the electrical resistance of the heating element during its long service life should practically not change [15].

All modern electric heating systems can be divided into six groups according to their purpose:

1. means for heating insulated from the external environment;
2. non-insulated heating means and tools;
3. facilities for heating premises;
4. means for heating liquids;
5. means for cooking;
6. means for personal hygiene.

Due to a large number of modern electric heating systems, it is proposed to analyze them in two stages:

1. analysis of electric heating elements;
2. analysis of heating element power management systems.

### 3.1. Analysis of electric heating elements

Electric heating elements can be divided according to the field of application since they are used to heat various environments [16]. They can be used to heat gases, liquids and solids [17]. Depending on the environment of use, choose a heater [18]. The main requirement when choosing a heater housing is the ability to withstand the destructive effects of the external environment.

In addition, when choosing electric heating elements, the operating temperature of the heating medium is often used.

For the manufacture of heaters with an operating temperature of up to 1500 K, the most common materials are nichrome, ferals, as well as chrome-nickel heat-resistant alloys.

Heaters made of nichrome and feral can be exposed or protected. In the first case, the design of the heater must be quite rigid, so it is made of wire and tape in large sections.

Open heating elements are used in furnaces and household heating devices, they can be wire zigzag, wire spiral and tape. The diameter and pitch of the spiral depends on the thickness of the wire and tape, as well as on the method of their attachment (Figure 1).



**Figure 1:** Open heating elements

At working heating temperatures up to 1000 K, tubular heating elements are used. A metal tube of which is filled with heat-conducting electrical insulating material, in which there is an electric heating spiral. The electrically insulating material is fused periclase.

Compared to open heating elements, tubular heating elements are more electrically safe, and can work in water, liquid hydrocarbons, liquid metal, molten salts, oxides and other media. They are resistant to vibrations and mechanical loads. Power of tubular heating elements – from 100 W to 15 kW, operating voltage – 36-380 V, operating temperature – 400-1000 K. Their service life – 10-40 thousand hours and more.

Molybdenum disilicide heaters are made by powder metallurgy. They can work at high temperatures up to – 2100 K. In addition, such heating elements can work in an oxidizing environment. However, their operation in an oxidizing environment at a temperature above 1900 K is undesirable, as it can lead to the destruction of the heating element.

Ceramic heating elements use the properties of some ceramic materials to acquire high electrical conductivity with increasing temperature. This material can be zirconium oxide. With the help of these heating elements, temperatures up to 2300 K can be reached.

High-temperature installations (with an operating temperature of 2300 K and above) use heating elements made of refractory metals, graphite and coal.

To manufacture heating elements from refractory metals, molybdenum, tantalum, and tungsten are used in the form of wire, tape, rods, and sheets. Such heating elements work only in an atmosphere of inert gases: argon, helium, hydrogen, nitrogen, and even in a vacuum.

Graphite heating elements are used in installations with an operating temperature of 1800-2700 K, while their use is limited due to intensive oxidation in air, starting at a temperature of 800 K. These heaters are manufactured in the form of rods with a round or square section, as well as in the form of pipes up to 1000-1500 mm. Heating elements based on graphite fibers (cable heating elements) with a heating temperature of up to 373 K are also widely used in everyday life.

### **3.2. Analysis of heating element power management systems**

Despite the wide selection of modern heating elements, working with them is impossible without using a heating control system (CS). That is, to power any electric heating element, a controlled switch must be included, which regulates the supply of electricity [19].

The simplest CS is the relay power supply of the heating element. Modern relay power supply systems (MRPS) are widely used in various industrial technological processes in science and everyday life [20]. It is important that switching on is carried out when there is a need to increase the temperature of the heating element, and switching off – when it is necessary to reduce the temperature.

The existing (rather cheap) MRPS of the heating element cannot always support the required mode of operation, because after the heating element is turned off, it continues to gain temperature for some time, regardless of the lack of power. When power is supplied to the heating element, on the contrary, the temperature continues to fall for some time, and only later begins to rise. This is especially noticeable when the system has high thermal inertia. An example of such a system is water-electric boilers, in which water directly contacts the heating element and significantly increases the thermal inertia of the system. Such systems are most often powered by alternating current (AC– alternating current) [21].

There is also a fairly large group of MRPS heating power elements, which are carried out by direct current (DC – direct current) [21]. This power supply is made by converting alternating current into direct current. That is, in addition to the controllable switch, such MRPS heating elements contain an AC-to-DC power conversion unit. They are more manageable, but also cannot always support the required mode of operation. Especially when you need to keep the temperature within one Kelvin. For example, in incubators, installations for scientific research or other high-precision heating devices.

There are also CS heating elements, which include a device for changing the power supply. Unlike the previous ones, such CS heating elements can better maintain the temperature regime. However, in order to reach the required temperature, such CSs are brought to the so-called stationary thermal mode by the heating element, which consumes a lot of time and thermal electricity.

Control of all the listed CSs of the heating element is carried out by measuring the temperature of the coolant or the surface of the heating element. The high thermal inertia of the heating element makes it difficult to maintain the thermal regime.

## **4. Creation of a virtual microcontroller system of relay power supply of the heating element**

Knowing the main shortcomings of the CS of the heating element that exists, it is proposed to create a virtual microcontroller (VM) MRPS of the heating element, which will allow:

- simulation of the operation of the components of the heating element's VM MRPS;
- create, edit and execute program code for a microcontroller;
- receive and store digital modelling information.

It is possible to achieve this by using a microcontroller for control [22]. The microcontroller will be able to evaluate the information it will receive and create, controlling the pulses to turn on the DC source. This way of controlling the heating element will be carried out programmatically, without human intervention (that is, autonomously) [23–25].

It is proposed to supply the VM MRPS with direct current with the verification of two main parameters:

- the presence of voltage applied to the heating element;
- surface temperature of the heating element.

However, it is impossible to develop the proposed VM MRPS without developing theoretical foundations. Which, in turn, should take into account the possibilities of the experimental installation of the VM MRPS. The authors determined the components of the experimental installation of the VM MRPS. The proposed installation is shown in the block diagram (Figure 2).

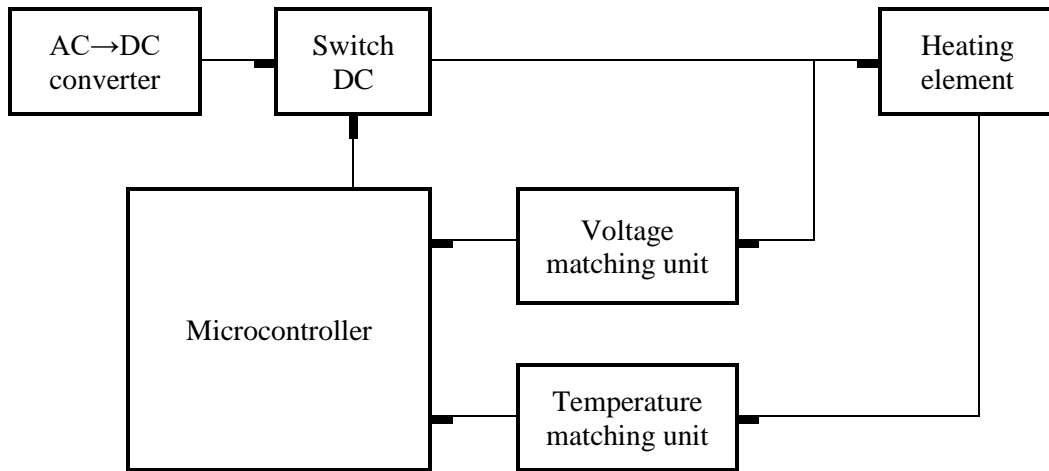

**Figure 2:** Block diagram of the experimental installation of the VM MRPS

AC→DC a circuit converter is designed to convert alternating current to direct current.

A DC switch, which is controlled by a microcontroller, interrupts the power supply or restores it as needed.

From the block diagram, it can be seen that the connection of the DC switch and the heating element allows obtaining information for the microcontroller about the voltage consumed by the heating element. The temperature sensor (represented in the diagram by the connection of the heating element and the temperature matching unit), which is located on its surface, provides information about the temperature. That is, the microcontroller receives from two sources the information it needs, which characterizes the operation of the heating element. All sources of information are connected to the microcontroller through the appropriate matching blocks. These blocks are designed to protect the microcontroller from damage and match its inputs [26].

Although the block diagram of the experimental installation of the VM MRPS is quite simple, writing the software code for its operation is impossible without a clear idea of the process of controlling the heating element.

VM MRPS should work in automatic temperature control mode. For this, it is necessary to maintain the appropriate temperature regime, which will further reduce the specific consumption of electricity [27].

The heating process can be described by the formula:

$$\tau(t) = \tau_r \left(1 - e^{-\frac{t}{T}}\right), \quad (1)$$

where  $\tau(t)$  – heater temperature, depending on the heating time;

$\tau_r$  – relation heating temperature;

$e$  – the base of the natural logarithm;

$t$  – heating time;

$T$  – heating time constant.

The heating time constant  $T$  is numerically equal to the ratio of the heat capacity of the heater to its heat output. The dependence of heater temperature on time (heating process) is presented on Figure 3.

The cooling process can be described by the formula:

$$\tau(t) = \tau_r \cdot e^{-\frac{t}{T}}, \quad (2)$$

where  $\tau(t)$  – heater temperature depending on the cooling time;

$\tau_r$  – relation cooling temperature;

$e$  – the base of the natural logarithm;

$t$  – cooling time;

$T$  – cooling time constant.

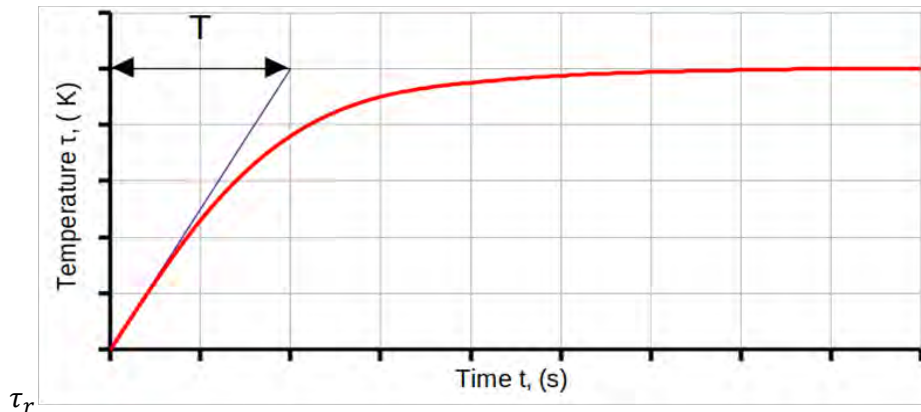

**Figure 3:** Dependence of heater temperature on time (heating)

The dependence of the heater temperature on time (cooling process) is presented in Figure 4.

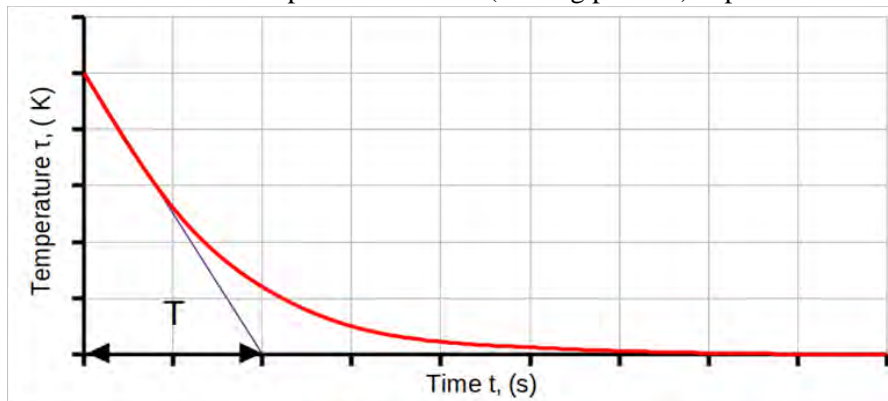

**Figure 4:** Dependence of heater temperature on time (cooling)

In order to create a VM MRPS, it is necessary to decide on the existing software for simulating the work of a microcontroller [28]. The main requirements for choosing a software for modeling the work of the VM MRPS are:

- creation, editing and execution of microcontroller software code;
- simulation of the operation of the microcontroller and the components of the block diagram of the experimental installation of VM MRPS (Figure 2);
- output of graphical information about the modeling process;
- output of digital information related to the modeling process;
- free software product;
- the possibility of use is not limited by the time of use;
- equipment on which it is possible to carry out the modeling process;
- cross-platform software.

The online service Autodesk TinkerCAD [28] meets all the conditions listed above. That is why it was chosen to create a virtual mock-up of the experimental installation of the VM MRPS. Autodesk TinkerCAD is an online service and modeling environment for working with 3D objects and electronic circuits. Distinctive features are openness, free access, rich functionality. Because TinkerCAD is often used in education, our privacy and security practices are carefully designed to protect students and provide a safe learning environment [29].

TinkerCAD contains several types of microcontrollers and many different peripheral components designed for modeling various technological processes. During a detailed analysis of the operation of the selected software, it was established that there is a possibility of creating all the components of the block diagram of the experimental installation of VM MRPS (Figure 2). However, the process of

modeling such an installation will be complicated, since the heating element (which can be created with existing components in TinkerCAD) will be quite difficult to model in the program code.

This is due to the lack of a model of the heating element, which will change its temperature depending on the action of electric current on it. However, there is a simpler way of modeling the heating process, which is associated with replacing the process of heating (cooling) the heating element with the process of charging (discharging) the capacitor. However, for such a replacement, one must first analyze its adequacy [30]. Table 1 was compiled to compare the specified processes.

**Table 1**

Comparison table of the processes of heating (cooling) the heating element and charging (discharging) the capacitor

Heating element	Capacitor
Heating $\tau(t) = \tau_r \left(1 - e^{-\frac{t}{T}}\right)$	Charging $U(t) = U_r \left(1 - e^{-\frac{t}{RC}}\right)$
Cooling $\tau(t) = \tau_r \cdot e^{-\frac{t}{T}}$	Discharge $U(t) = U_r \cdot e^{-\frac{t}{RC}}$

Table 1 shows that by three symbolic substitutions:

- $RC$  to  $T$ ;
- $U_r$  to  $\tau_r$ ;
- $U(t)$  to  $\tau(t)$ .

It is possible to convert the equations related to charging (discharging) the capacitor into the equations related to heating (cooling) the heating element.

This confirms the adequacy of the proposed model of replacing the process of heating (cooling) the heating element with the process of charging (discharging) the capacitor.

After a detailed analysis of the block diagram of the experimental installation of VM MRPS (Figure 2), the following electrical scheme is proposed for modeling the process (Figure 5).

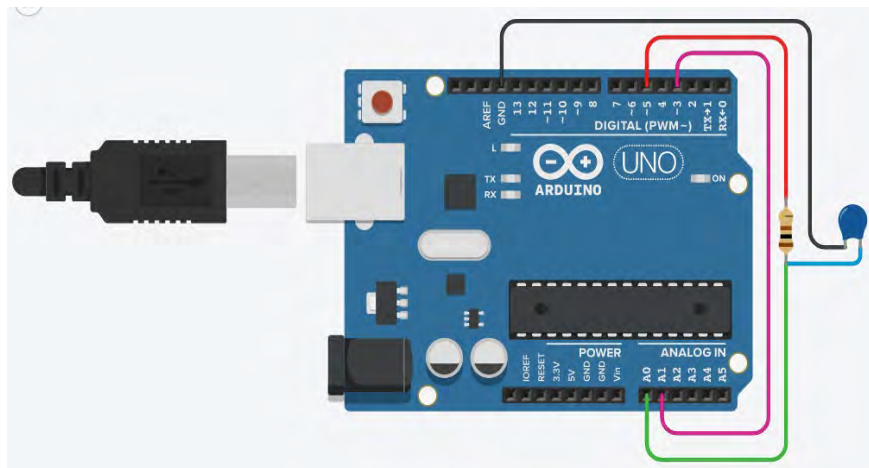

**Figure 5:** Electric scheme of the experimental installation of the VM MRPS

The electrical diagram of the experimental installation of the VM MRPS contains (Figure 5):

1. board – Arduino UNO;
2. resistor;
3. capacitor.

Board – Arduino UNO in the electrical circuit of the installation is intended for modeling almost all elements of the block diagram of the VM MRPS installation (Figure 2).

The external elements of the resistor and capacitor circuit are designed to simulate heating and cooling. The connection is made according to the classic scheme, designed to study the process of charging and discharging the capacitor (Figure 6).

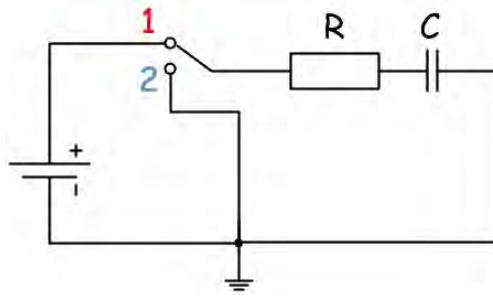

**Figure 6:** Electrical diagram of the connection of the capacitor and resistor in the experimental installation of VM MRPS

Control of the discharge and charge of the capacitor is implemented through output – 5, which is supplied with power or turned off. Imitating the position of the switch in Figure 6:

1. the capacitor is supplied with power;
2. the capacitor is powered off.

For this, a red wire was used between output – 5 and the resistor (Figure 5). The green wire connecting the capacitor, resistor and input A0 is designed to control the charge voltage of the capacitor.

The pink wire connecting output – 3 and input A1 is designed to control the presence or absence of capacitor power. The black wire connects the capacitor and GND.

A fairly simple electrical scheme of the experimental installation of the VM MRPS assumes that the main load on the simulation process will be taken over by the control program.

## 5. Creation of the software of the virtual microcontroller system of the relay power supply of the heating element

The operation of the experimental installation of VM MRPS is impossible without the creation of appropriate software.

The presented block diagram provides for the creation of software code for modeling two complete heating and cooling circulations (Figure 7).

At the beginning of the program, it is necessary to initialize the variables and enter the constants that are necessary for the operation of the scheme. Pin numbers of ports are assigned to such constants:

- input\_A0;
- input\_A1;
- output\_3;
- output\_5.

It is also necessary to enter the initial and final values of the circulations:

- circulation\_0 (end values of the circulations);
- circulation\_1 (initial value of the circulations).

In addition, two one-dimensional arrays are used to form the time of heating/cooling and turning on/off the heater:

- time1 [200, 2200, 4200, 6200] (heater heating/cooling time);
- PWM [255, 0, 255, 0] (heater power on/off).

A value of PWM = 0 is used for full power off and a value of PWM = 255 is used for full power on.

Next, the serial port is configured for the exchange of alphanumeric information, namely, the exchange rate is set.

Then on the output ports, output\_3 and output\_5 are programmatically set – 0 V (disconnect).

It is clear that the previous actions should be performed at the beginning and only once.

After that, the main circulation of the program begins, which will be executed until the circulation\_1 change reaches the value of the circulation\_0 constant.



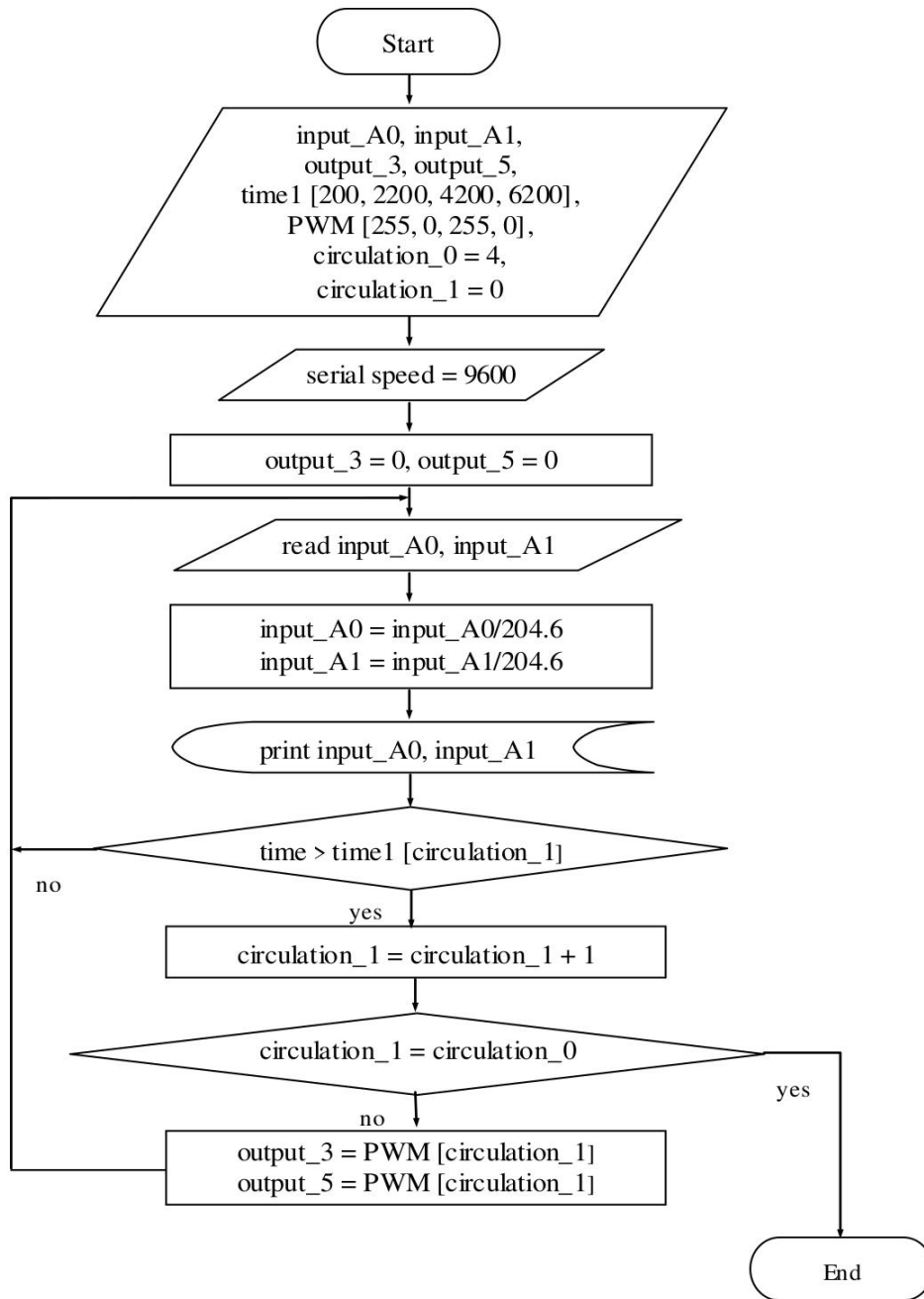

**Figure 7:** Block diagram of the simulation program of two complete heating and cooling circulations

The time before the first power change on the output ports output\_3 and output\_5 is 200 milliseconds, this will lead to the fact that the same ports will be programmed to  $-5$  V. The time before the next change is 2000 milliseconds. At the same time, simulations of full heating (up to the stationary stage) take place. Then programmatically set again  $-0$  V. Time until the next change  $-2000$  milliseconds. At the same time, complete cooling is simulated (to the stationary stage).

Next, the circulations of heating and cooling will be repeated once again. After that, the program will be completed because the variable circulation\_1 will reach the value of the constant circulation\_0.

## 6. Results & Discussion

In Ukraine, in connection with the significant increase in the price of the main energy carriers, users should choose the method and system of heating that is the most effective and has the possibility

of autonomous operation. Therefore, Ukraine should develop and implement an efficient, ecological and safe heating system for the further development of the country. The development and use of such heating systems are important factors in strengthening energy security and reducing the negative human-made impact on the environment. To create effective heating systems, it is necessary to have a virtual microcontroller system of relay power supply of the heating element.

The result of the simulation of two circulations of full heating and cooling on the experimental installation of the VM MRPS is presented in Figure 8.

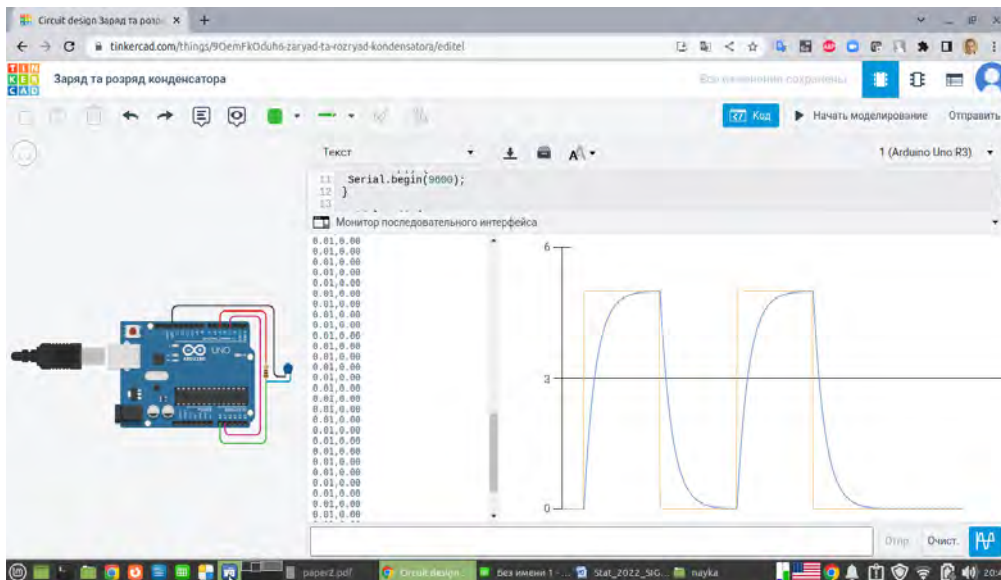

**Figure 8:** Modeling of two circulations of full heating and cooling on the experimental installation of VM MRPS

Figure 9 shows the result of a gradual decrease in the temperature of the heater with three control pulses.

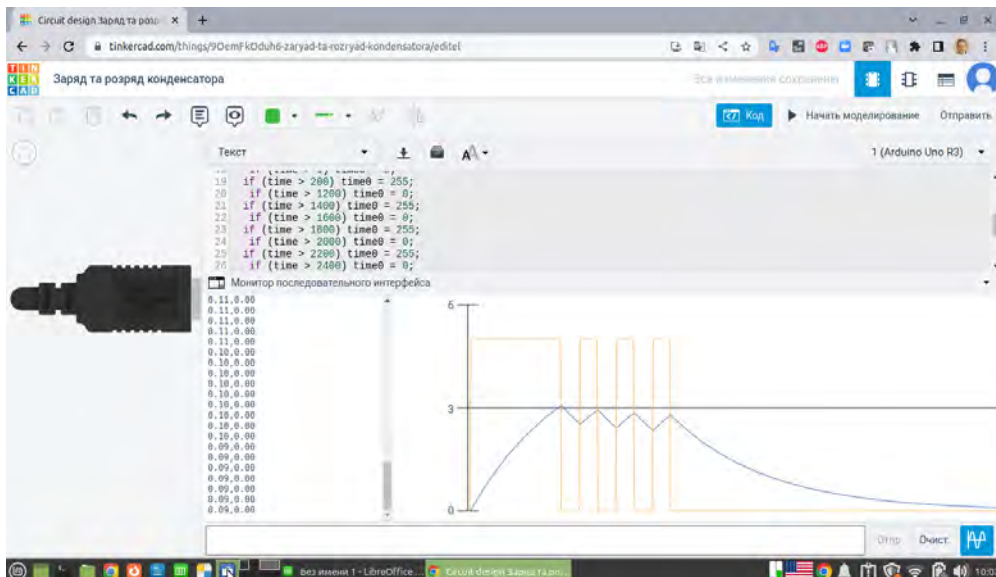

**Figure 9:** Modeling the gradual decrease in the temperature of the heater with three control pulses

There is also the possibility of using simulation data (after saving in a file) with other software tools: LibreOffice Calc, MicrosoftOffice Excel, etc. Such software tools can be used for reprocessing and comparison with the data obtained in the process of conducting experiments (Figure 10).

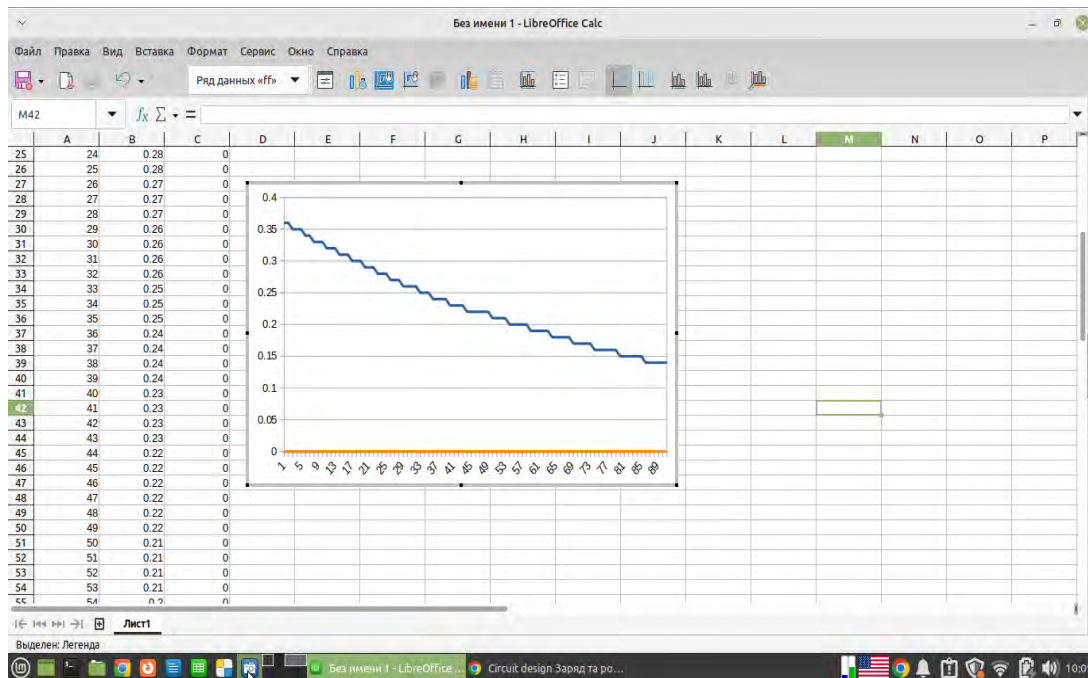

**Figure 10:** Using a piece of simulation data after saving it to a file (software – LibreOffice Calc)

The authors plan to continue work on the further improvement of the experimental installation of the VM MRPS.

## 7. Conclusions

The article examines the theoretical and practical foundations of creating a virtual microcontroller system for the relay power supply of the heating element. The basis for the creation of VM MRPS is the analysis of modern electric heating systems, which is performed in two stages.

The authors determined the components of the experimental setup for the creation of the VM MRPS. However, writing the software code for its operation is impossible without understanding the process of controlling the heating element.

The authors paid special attention to the selection of software for simulating the operation of the microcontroller, for which the main selection requirements were formed. Autodesk TinkerCAD, an online service, was chosen as the modeling environment.

After analyzing the capabilities of the selected software, a method of modeling the heating process was proposed, which involves replacing the process of heating (cooling) the heating element with the process of charging (discharging) the capacitor. To verify this modeling method, the authors analyzed and checked the adequacy of the proposed model.

Using the capabilities of the selected process modeling software, an electrical circuit was also proposed.

In addition, to check the operation of the electrical circuit, the appropriate software VM MRPS was created. The results of the work can be used in the educational process and scientific activity.

In the future, the authors plan to check the conformity of the results of the VM MRPS with a real heater with similar input parameters.

In addition, the authors plan to devote further research to the implementation of the PID regulator in the VM MRPS. The next step will be the implementation of the program for the automatic selection of the PID regulator coefficients depending on the change of actions on the heater of the external environment. The purpose of this study will be the creation of an automatic microcontroller PID regulator.

## 8. References

- [1] Gang Zhang, Yunyi Niu, Tuo Xie, Kaoshe Zhang. Multi-level distributed demand response study for a multi-park integrated energy system. *Energy Reports*. Volume 9, (2023), Pp. 2676-2689.
- [2] Dababneh, F., Li, L., 2019. Integrated electricity and natural gas demand re-sponsor for manufacturers in the smart grid. *IEEE Trans. Smart Grid* 10 (4), 4164–4174. URL: <http://dx.doi.org/10.1109/TSG.2018.2850841>.
- [3] Helistö, N., Kiviluoma, J., Holttinen, H., 2018. Long-term impact of variable generation and demand side flexibility on thermal power generation. *IET Renew. Power Gener.* 12 (6), 718–726. URL: <http://dx.doi.org/10.1049/IET-RPG.2017.0107>.
- [4] Mei, J., Wei, Z., Zhang, Y., Ma, Z., Chen, S., Sun, G., 2019. Hybrid control of integrated power and gas energy systems based on significant contingency screening. *Dianwang Jishu/Power Syst. Technol.* 43 (1), 23–31. URL: <http://dx.doi.org/10.13335/J.1000-3673.PST.2018.2623>.
- [5] Ni, L., Liu, W., Wen, F., Xue, Y., Dong, Z., Zheng, Y., Zhang, R., 2018. Optimal operation of electricity, natural gas and heat systems considering integrated demand responses and diversified storage devices. *J. Mod. Power Syst. Clean Energy* 6 (3), 423–437. <http://dx.doi.org/10.1007/S40565-017-0360-6/TABLES/7>.
- [6] S. Danech, A. Agarwal, P. Mahajan and S.M. Dhavale. Implementation of PID Based Automatic Temperature Control System using STM32, 2022 6th International Conference on Computing, Communication, Control and Automation (ICCUBEA, Pune, India, 2022, pp. 1-5, doi: 10.1109/ICCUBEA54992.2022.10010800.
- [7] G.A. Prakoso, I.A. Aryanto and M.O. Hasanuddin. Heating Element Temperature Rise Rate Control With IC555 Timer as an Astable Multivibrator, 2022 International Symposium on Electronics and Smart Devices (ISESD), Bandung, Indonesia, 2022, pp. 1-6, doi: 10.1109/ISESD56103.2022.9980615.
- [8] V.R. Pasupuleti, M.S. Pravallika, K. Spandana and S. Jalal. An IoT based Embedded System for Monitoring and Control of Greenhouse parameters, 2022 3rd International Conference on Smart Electronics and Communication (ICOSEC), Trichy, India, 2022, pp. 390-397, doi: 10.1109/ICOSEC54921.2022.9951966.
- [9] Yajie Liu. Smart Greenhouse Monitoring and Controlling based on NodeMCU. *International Journal of Advanced Computer Science and Applications (IJACSA)*, 13(9), 2022. URL: <http://dx.doi.org/10.14569/IJACSA.2022.0130970>.
- [10] Herrera Morales, Javier and al. Solar Dryer with Electronic PID Controller for Dry Potato Production. *Ecological Engineering & Environmental Technology*, vol. 23, №1, 2022, pp. 223-229. doi:10.12912/27197050/143784.
- [11] Al-Dahoud and M. Fezari. Improving Monitoring Greenhouse System using Smart wireless Sensors Actuators Network, 2021 International Conference on Information Technology (ICIT), Amman, Jordan, 2021, pp. 212-217, doi: 10.1109/ICIT52682.2021.9491685.
- [12] G.M. Debele and X. Qian. Automatic Room Temperature Control System Using Arduino UNO R3 and DHT11 Sensor, 2020 17th International Computer Conference on Wavelet Active Media Technology and Information Processing (ICCWAMTIP), Chengdu, China, 2020, pp. 428-432, doi: 10.1109/ICCWAMTIP51612.2020.9317307.
- [13] F.H. Sakaci and Ş.Ç. Yener. Design of a Microcontroller-Based Heating System Controller Using Fuzzy Logic, 2021 Innovations in Intelligent Systems and Applications Conference (ASYU), Elazig, Turkey, 2021, pp. 1-4, doi: 10.1109/ASYU52992.2021.9599011.
- [14] Yangyang Fu, Zheng O'Neill, Jin Wen, Amanda Pertzborn, Steven T. Bushby. Utilizing commercial heating, ventilating, and air conditioning systems to provide grid service. *Applied Energy*. Volume 307, February 2022. URL: <https://doi.org/10.1016/j.apenergy.2021.118133>.
- [15] Chen, P., Bao, Y.Q., Zhu, X., Zhang, J., Hu, M., 2019. Day-ahead scheduling of large numbers of thermostatically controlled loads based on equivalent energy storage model. *J. Mod. Power Syst. Clean Energy* 7 (3), 579–588. URL: <http://dx.doi.org/10.1007/S40565-018-0468-3>.
- [16] Shi, Z., Wang, G., Liu, C., Qiang Lv, Baoli Gong, Zhang, Y., Yan, Y. Optimizing the Transient Performance of Thermoelectric Generator with PCM by Taguchi Method. *Energies* 2023, 16(2), 805. URL: <https://doi.org/10.3390/en16020805>.

- [17] Viorel Ionescu. Performance analysis of thermoelectric power-generation system with natural convection cooling. 3rd International Conference on Power, Energy and Electrical Engineering (PEEE 2022) 18–20 November 2022 Faculty of Applied Science and Engineering, Ovidius University of Constanta, Constanta, 900527, Romania. Energy Reports. Volume 9, (2023), Pp. 123-130.
- [18] K. Heng, X. Yang, X. Wu and J. Ye. A 3-D Thermal Network Model for Monitoring of IGBT Modules, in IEEE Transactions on Electron Devices, vol. 70, no. 2, pp. 653-661, Feb. 2023, doi: 10.1109/TED.2022.3227004.
- [19] T. Yang, F. Diao, H.A. Mantooth, Y. Zhao, W.P. King and N. Miljkovic. Heat Spreader Thermal Switch for Power Converter Isothermalization, in IEEE Transactions on Components, Packaging and Manufacturing Technology, vol. 12, no. 7, pp. 1063-1081, July 2022, doi: 10.1109/TCPMT.2022.3185972.
- [20] Zasornov A. Experimental investigation of multilayer thermal insulation material performance with using of discrete heat transfer model / A. Zasornov, I. Zasornova, I Marynchenko // Vlakna & Textil. Indexed in SCOPUS Chemical Abstracts World Textiles. Volume 27. – №4. – 2020. – Pp. 138-144. ISSN 1335-0617 print version. ISSN 2585-8890 online version.
- [21] J. Arévalo Soler, D. Groß, EP Araujo ra OG Bellmunt. Interconnecting power converter control role assignment in grids with multiple AC and DC subgrids, in IEEE Transactions on Power Delivery, doi: 10.1109/TPWRD.2023.3236977.
- [22] Berjawi, A.E.H., Walker, S.L., Patsios, C., Hosseini, S.H.R., 2021. An evaluation framework for future integrated energy systems: A whole energy systems approach. Renew. Sustain. Energy Rev. 145, 111163. URL: <http://dx.doi.org/10.1016/J.RSER.2021.111163>.
- [23] Virat, A., Ashish, A., Patel, R., Dash, R.N. (2023). Analysis and Controlling of Distribution Transformer Parameter using AVR Microcontroller IoT System. In: Dash, R.N., Rathore, A.K., Khadkikar, V., Patel, R., Debnath, M. (eds) Smart Technologies for Power and Green Energy. Lecture Notes in Networks and Systems, vol 443. Springer, Singapore. URL: [https://doi.org/10.1007/978-981-19-2764-5\\_22](https://doi.org/10.1007/978-981-19-2764-5_22).
- [24] P. Baen and F. Leija. Developing an IEEE Continuous Thermal Monitoring Standard and a Major Company's Protection of Their Electrical Assets: Exploring Continuous Thermal Monitoring for Electrical Connections and Components, in IEEE Industry Applications Magazine, vol. 29, no. 2, pp. 32-38, March 2023, doi: 10.1109/MIAS.2022.3218943.
- [25] H. Jamal, M. Waseem, I.A. Sajjad, A. Anjum, M.S. Khan, Low-cost feedback control thermal protection system for 3-phase distribution transformer using microcontroller, in 2018 IEEE International Conference on Smart Energy Grid Engineering (SEGE) (2018), pp. 200–204. URL: <https://doi.org/10.1109/SEGE.2018.8499489>.
- [26] M.N. Hibatullah, L. Gumilar and K.A. Zain. Monitoring of Protection System for Overvoltage Faults in Distribution Networks, 2022 International Conference on Electrical and Information Technology (IEIT), Malang, Indonesia, 2022, pp. 191-195, doi: 10.1109/IEIT56384.2022.9967912.
- [27] Alipour, M., Zare, K., Zareipour, H., Seyedi, H., 2019. Hedging strategies for heat and electricity consumers in the presence of real-time demand response programs. IEEE Trans. Sustain. Energy 10 (3), 1262–1270. URL: <http://dx.doi.org/10.1109/TSSTE.2018.2865380>.
- [28] O.E. Amestica, P.E. Melin, C.R. Duran-Faundez, G.R. Lagos. An experimental comparison of Arduino IDE compatible platforms for digital control and data acquisition applications, in 2019 IEEE CHILEAN Conference on Electrical, Electronics Engineering, Information and Communication Technologies (CHILECON) (2019), pp. 1–6. URL: <https://doi.org/10.1109/CHILECON47746.2019.8986865>.
- [29] Autodesk tinkercad. URL: <https://www.tinkercad.com/>.
- [30] A. Crosara, E. Tómasson and L. Söder. Generation Adequacy in the Nordic and Baltic Area: The Potential of Flexible Residential Electric Heating, 2019 IEEE PES Innovative Smart Grid Technologies Europe (ISGT-Europe), Bucharest, Romania, 2019, pp. 1-5, doi: 10.1109/ISGTEurope.2019.8905720.