

EXPERIMENTAL RESULTS FROM A MICROWAVE CAVITY BEAM POSITION MONITOR

V. Balakin, A. Bazhan, P. Lunev, N. Solyak, V. Vogel, P. Zhogolev, BINP, Protvino, Russia

A. Lisitsyn, SSIE "Istok", Moscow, Russia

V. Yakimenko, BNL, Upton, NY.

Abstract

Future Linear Colliders have hard requirements for the beam transverse position stability in the accelerator. A beam Position Monitor (BPM) with the resolution better than 0.1 micron in the single bunch regime is needed to control the stability of the beam position along the linac. Proposed BPM is based on the measurement of the asymmetrical mode excited by single bunch in the cavity. Four stages of signal processing (space-, time-, frequency- and phase-filtering providing the required signal- to-noise ratio) are used to obtain extremely high resolution. The measurement set-up was designed by BINP and installed at ATF/BNL to test experimentally this concept. The set-up includes three two-coordinates BPM's at the frequency of 13.566 GHz, and reference intensity/phase cavity. BPM's were mounted on support table. The two-coordinates movers allow to move and align BPM's along the straight line, using the signals from the beam. The position of each monitor is controlled by the sensors with the accuracy 0.03 micron. The information from three monitors allows to exclude angle and position jitter of the beam and measure BPM resolution.. In the experiments the resolution of about 0.15 micron for 0.25 nC beam intensity was obtained, that is close to the value required.

1 INTRODUCTION

The first linear collider was proposed in 1978 as a way to a very high energies in electron-positron collisions[1]. Today a few projects of LC are under development [2]. For all the projects, the beam jitter should be less than 0.1 micron in the main linac and a few nanometres in final focus system (FFS), otherwise the luminosity will decrease. The simple and most effective microwave BPM is a circular cavity, excited in TM_{110} -mode by an off-axis beam. The cavity-type BPM has potentially a high resolution and can provide requirements for future colliders. By now, a few various designs of BPM's have been proposed and developed for a broad frequency range from 1.5 GHz (TESLA) up-to 33 GHz (CLIC) [4-10]. In this paper, our concept of signal processing for obtaining high resolution is presented [3], and the results of experimental studies of limitation in resolution are discussed.

The high frequency BPM has a submicron resolution. Today it seems impossible to find test beam with the

required transverse stability to measure the resolution in BPM. Nevertheless it is possible to verify BPM even when the beam jitter is much high than the expected resolution[4]. Figure 1 explains how to verify the intrinsic BPM resolution using three BPMs irrespective of the

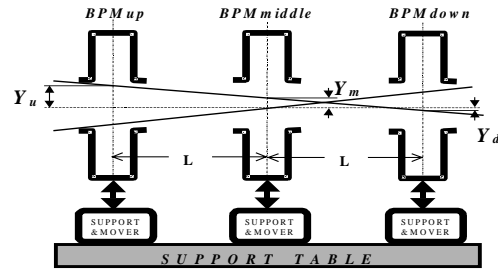

Figure 1. Set-up for determine intrinsic BPM resolution.

beam jitter. If all the BPM's are located close to each other, the beam trajectories are linear and the half-sum of beam off-sets in the first and last BPM's should be equal to that in the middle BPM. All measurement points should be in line (as shown in Fig.1). The dispersion points around this line yield the BPM resolution.

The measured amplitude of the transverse mode is proportional to the beam offset and bunch charge:

$$P = \frac{\omega^2}{2Q} S^2 M^2 \rho' (k\Delta x)^2 q^2 \quad (1)$$

Where q is the beam charge, Q - loaded quality factor, ρ' - normalised transverse shunt impedance; M - beam transit time factor; $S = \exp(-\omega^2 \sigma_z^2 / 2c^2)$ - space factor.

The phase of the oscillations depends on the direction of the beam offset. One of the main problems is a large amplitude of the fundamental mode and other symmetrical modes that are excited in the cavity by the beam irrespective of it's offset. These modes must be strongly dumped.

The thermal noise as well as a noise coming from electronics determine another limit of resolution. The upper limit of resolution can be achieved when the power of the signal (1) is equal to that of the thermal noise $P = 4kT(\Delta f)$. Assuming $(\Delta f) = f/Q$ we obtain

$$(\Delta x)_{\min} = \frac{\lambda}{2\pi \cdot q} \sqrt{\frac{4kT}{\omega \rho'_{ef}}} \quad (2)$$

where λ means the wavelength, $\rho_{ef} = \rho' M^2 S^2$ - normalized effective shunt impedance, T -temperature, k -Boltzman constant.

Estimation for 14 GHz BPM shows that the limitation coming from the thermal noise of electronics is of the order of a few nanometres.

2 CONCEPT OF SIGNAL PROCESSING

A more serious limitation appears from the symmetrical modes. For example, the dumping of E_{010} mode should be better than 140 dB for obtaining 1 nm resolution. The frequency filtration dumps this mode only by the factor

$$r = Q_{110}^2 \left(1 - \frac{\omega_{010}^2}{\omega_{110}^2}\right) \quad (3)$$

which is typically gives 60 dB. An extremely high resolution can be achieved by using a few stages of signal processing: “space-“, “time-“, frequency- and “phase-“ filtering [3].

2.1 “Space filter”

Symmetrical and transverse modes have different field space distribution in the cavity and this fact can be used for filtering. Usually, in a BMP two pick-up antennas are used, whose signals are combined in a magic T. For symmetrical modes signals subtract, and for transverse ones add up. It gives typically a 20-30 dB additional dumping. The disadvantage of this method is effect of temperature on the amplitude difference and phase shift between the signals from antennas, especially if long cables are used. Another solution is to extract only the transverse mode signal from the cavity using a special geometry of output. In this case, the length of cable from antenna to RF circuit doesn't matter and the dumping of about 30-40 dB is available.

2.2 “Time filter”

The sharp front of the single bunch signal from the cavity provides wide spectrum from each resonant mode. It

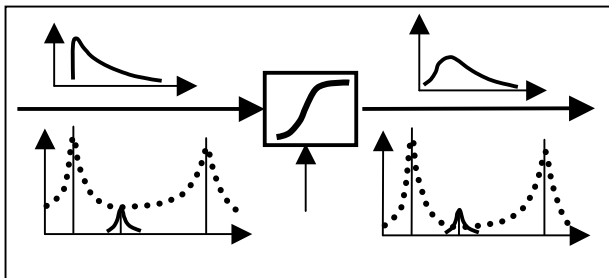

Figure 2. Beam driven RF pulse (top) and spectrum (bottom) before (left) and after (right) RF-switch.

means that at the operating frequency we have a signal from symmetrical modes. The common mode rejection by frequency discrimination is defined by equation (3) and is

typically 60 dB. Within the rejection by “space filter” it gives approximately 100 dB. Further rejection 40 dB or more can be received by using a new method of “time filtration” proposed in [3]. The idea is to smooth sharp front of the signal, excited by bunch. For this purpose a special time “gate” (controlled RF switch) installed between cavity and the RF circuit. The gate is closed during sharp front and then open smoothly, as it shown in Figure 2. Additional attenuation of the signal from symmetrical mode depends on the switching time and can

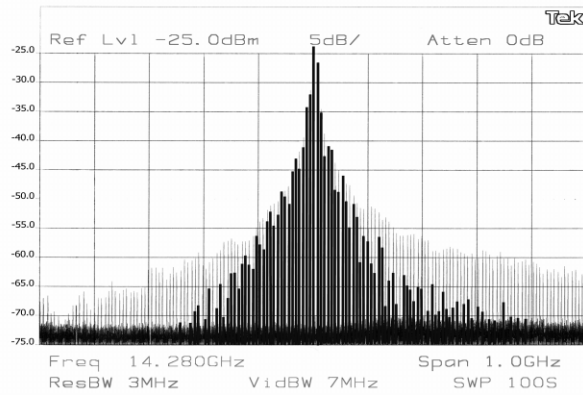

Figure 3. Spectrum of RF signal with and without switch

be very high, limited mostly by switch isolation. Two experimentally measured spectra excited by a single bunch in the cavity are shown in Fig.3 (with an RF switch and without any) for demonstration of this method.

2.3 Frequency filter and phase detector

The signal is filtered at a frequency of transverse mode with pass-band in order to $\Delta f = f_{110}/Q_{110}$ to minimize the thermal noise. Phase detecting allow to measure sign of beam displacement. This part is shown in Fig.5.

This concept of signal processing has been realized in our design of BPM. The aim of the experiment was to obtain the maximum BPM resolution with a real beam jitter and to study possible limitations.

3 EXPERIMENTAL SET-UP

The experiment was performed at on the ATF/BNL linac, operating in a single bunch regime. Beam parameters were: $U=45\pm 1$ MeV, $q=0.25\pm 0.5$ nC, the longitudinal beam size 5 - 10 ps and transverse jitter about 25 μ m along the beam-line, where the set-up was installed. [11].

Figure 4 represents the setup of the experiment. Three prototypes of BPM cavities were manufactured for this experiment. Each BPM was placed on a high precision electromagnetic mover allowing to move the cavity in both directions (X and Y) in the range of ± 1 mm with step equal 0,3 μ m. This allowed to align and calibrate the BPM's. The position of the movers was controlled with

the accuracy $0.03 \mu\text{m}$ with respect to the support table. All magnetic elements were magnetically shielded to exclude the effects on the beam. All the three movers were placed on the support table and aligned using standard ATF procedure. To achieve an unrestricted motion of the BPMs, they were connected to the vacuum channel via bellows. Before the experiment started, all the movers had been calibrated.

The detection electronics allowed to take and process data pulse to pulse independently in horizontal and vertical positions in each BPM. Tests BPMs and detection electronics in the lab showed that the potential BPM

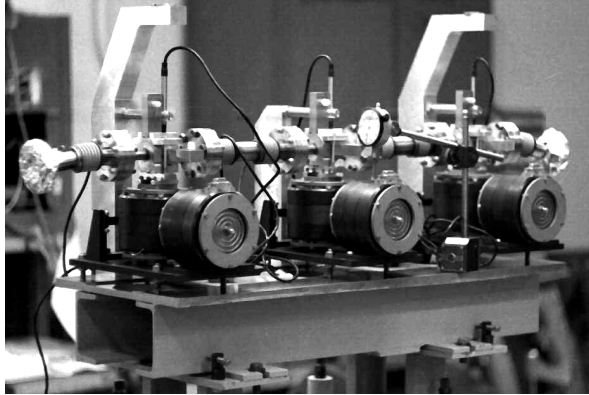

Figure 4. Experimental setup

resolution for ATF beam parameters should be less than $0.1 \mu\text{m}$. Each BPM has two outputs for the horizontal and vertical signal coupled with detection electronics by 4m RF-cables because electronics was placed outside of the tunnel.

Before the test started the TM_{110} -mode resonant frequency of each BPM had been measured and tuned. For fine tuning thermal heating was used. Each BPM had individual heater with feedback temperature stabilization, which automatically kept the frequency at the desired value.

4 RF ELECTRONICS

Figure 5 represents the detection electronics used in the experiment for measurements in the horizontal (X) and vertical (Y) directions. These circuits comprise a RF-switch, a band-pass filter, a mixer, a phase detector, an intermediate frequency amplifier, and a video amplifier for each monitor. As the laboratory tests showed that the electronics had sensitivity of about $6 \cdot 10^{-11} \text{ W}$ and the dynamic range close to 65 dB [4].

Afterwards the signal was transmitted from RF electronics to the analog-digital converter (ADC) located in CAMAC. The precision mover was controlled by CAMAC, too. The above circuit allowed to find the coordinates for each single bunch of the beam.

As a reference signal the signal from the reference cavity had been planned to be used. However, at the first

stage signal from ATF reference line at frequency $f=2856 \text{ MHz}$ was used that was multiplied by factor 5 for mixing down and divided by factor 4 for phase detecting

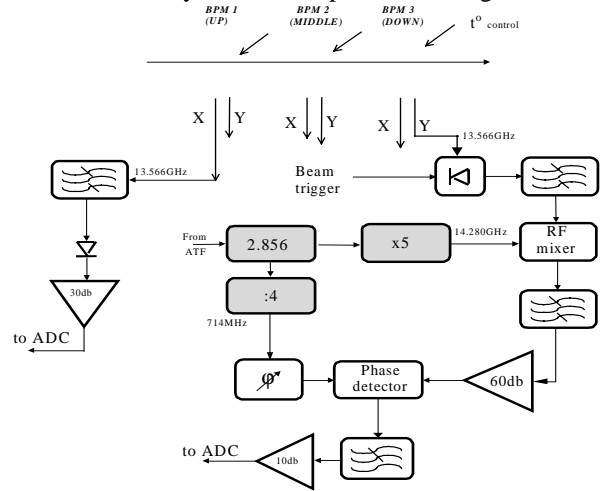

Figure 5. RF circuit.

The information about the beam intensity and phase (with respect to the reference line) of the beam was obtained from the reference cavity. The scheme of an RF circuit for this measurement is shown in Figure 6.

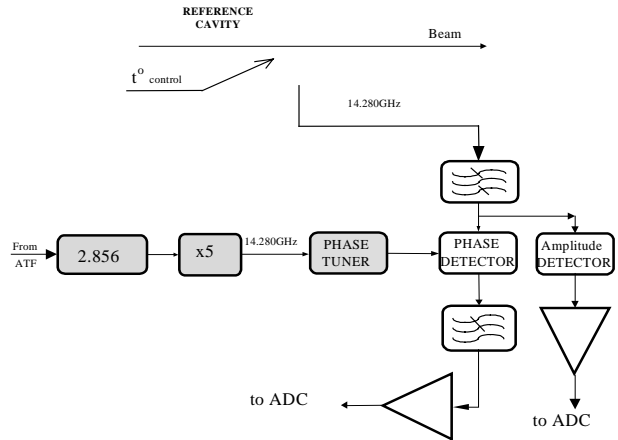

Figure 6. RF electronics for phase and amplitude control.

5 RESULTS

Before data taking began, the beam was placed as close to the centers of BPMs as possible using ATF equipment. For this procedure, in all measuring channels a crystal detector was used (see Fig.5 for the X channel). After that Y (or X)-channels in each BPM were connected to the circuits for phase measurements. Then all BPMs were moved off from the centre so as to provide a clear displacement signal for tuning of the detection circuit in phase measurements. For determination of sensitivity each BPM was moved in the range of $\pm 35 \mu\text{m}$ with the step equal to $0.3 \mu\text{m}$. Beam jitter had been excluded by

fitting the measured data. These sensitivities were used for calculating beam offset.

Afterwards, all the BPM's were moved to their fitted "zero" point for resolution measurements. The data obtained for the Y axis are shown in next Fig.7, where the beam off-set at the middle monitor is plotted as a function of the half-sum off-sets at the upstream and downstream monitors. The events with off-sets more than 10 μm in the X direction have been rejected (the coupling between modes of X and Y polarisation modes in the BPM cavity is about 40 dB). The resolution obtained in that run was 0.15 μm for 0.25 nC bunch charge or 38 for 1nC normalised value.

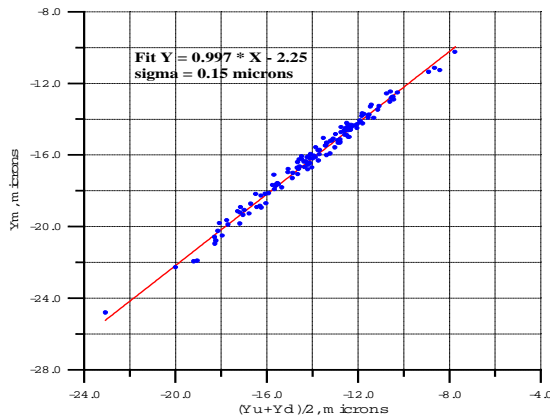

Figure 7. Determination of the BPM resolution.

All tests were made with the 10 dB attenuation of the output signal of BPMs to escape saturation of electronics due to a high beam jitter.

6 DISCUSSION

An entire resonant BPM system has been tested at the ATF/BNL using real beam with the predetermined position, angle, intensity and energy jitter. Under these conditions the resolution of 0.15 μm for 0.25nC beam charge was obtained. Three independent BPMs were used to exclude position and angle jitter. For absolute BPMs calibration precision movers were applied. The resolution attained is not the limit for this type of BPM. Its value was determined by the experiment condition. Unfortunately beam jitter exceeded dynamic range of used in the test electronics. Therefore, the BPM output signal was attenuated.

The phase of laser pulse in RF gun was not absolutely stable with respect to accelerating RF signal, which was used as the reference signal for phase measurements. That is why the "beam phase" has jitter with respect to reference oscillations which explains for the additional jitter noise in the output signal in the phase detection electronics. This jitter could not be excluded using three BPMs.

The beam trajectory along the BPMs was not absolutely rectilinear of the effect of the magnetic field

has influence on moving charged particles. And even in a permanent magnetic field (e.g., the magnetic field of the Earth) trajectory deflection from the line is not abiding. It is determined by the beam energy. Therefore, in resolution determination the energy jitter in an accelerator yields erroneous reading when three BPMs are used.

We believe that resolution better than 38 nm for 1nC can be obtained in our design of BPM. This result is close to the result received in experiment [7], where the resolution near 25 nm was demonstrated for BPM at frequency 5712 MHz. This experiment was done on FFTB/SLAC with a 1 nC beam intensity and jitter on the order of 0.14 μm (200 times less than in our case). In this experiment "time-filtering" of signal didn't used.

7 CONCLUSION

Now it seems possible to have a BPM with the resolution better than 100 nm. The level of 1nm resolution takes more studying. For experimental tests, a very stable beam is needed.

8 ACKNOWLEDGEMENTS

We would like to thank the ATF staff for their help and hospitality during our stay in BNL. Our special thanks are due to R.Palmer, Ilan Ben-Zvi and X. J. Wang for making the experiment possible, as well as for smoothly coordination of our communication and joint activities.

9 REFERENCES

- [1] V.Balakin, G.Budker, A.Skrinsky, "Feasibility of creating a superhigh energy colliding electron-positron beam facility", National Particle Accelerator Conference, 1978,Dubna, Russia, Trans.186, SLAC, 1978.
- [2] International Linear Collider Technical Review Committee Report (TRC) 1995., SLAC 1995.
- [3] V. Balakin " Concept BPM for VLEPP ", Proc. 3rd Intern. Workshop on Linear Colliders, v. 3, p. 155 (1991)
- [4] V. Balakin, V. Vogel, N. Solyak "The Model of BPM for VLEPP ", Proc. 3rd Int. Workshop on Linear Colliders, v. 3, p. 188 (1991)
- [5] W.Schnell "Common-mode rejection in resonant microwave position monitors for linear colliders" CERN-LEP-RF/88-41, CLIC Note 70.
- [6] V. Balakin, A. Bazhan, P. Lunev et al., "Beam Position Monitor with nanometer resolution for Linear Collider", Proc. of the Fourth European Particle Accelerator Conference, v. 2, p. 1539 (1994).
- [7] T.Slaton, G.Mazaheri,T. Shintake, "Development of nanometer resolution C-band radio frequency beam position monitors in the Final Focus Test Beam. Proc. of XIX International Linear Accelerator Conference (Linac98), Chicago, Illinois, August 23-28,1998.
- [8] W.Schnell, J.P.H.Sladen,I.Wilson,W.Wuensch, "CLIC beam position monitor developments", CLIC-Note 170, 1992.
- [9] J. P. H. Sladen, I. Wilson, W. Wuensch, "CLIC Beam Position Monitor Tests", CERN-LEP-RF (1996).
- [10] R. Lorenz, K. Yezza, "Test Results on Beam Position Monitor Prototype for the TTF", Proc. of the IV EPAC, v. 2, p. 1536 (1994).
- [11] K Batchelor, M. Babzien, I Ben-Zvi et al., "Operational experience on the Brookhaven National Laboratory Accelerator Test Facility", Proc. Fourth European Particle Accelerator Conference, v. 1, p. 736 (1994).