



08 March 2012

OFFICE ORDER NO. 67<sup>th</sup>  
Series of 2012

**Subject: IMPLEMENTATION OF IPOP HL- JPO PATENT PROSECUTION  
HIGHWAY**

The Intellectual Property Office of the Philippines (IPOP HL) – Japan Patent Office (JPO) Patent Prosecution Highway (PPH) on work sharing signed on February 9, 2012 will take effect on March 12, 2012.

Applications to be prosecuted under the PPH shall be subject to the guidelines herein attached as Annex A.

Applicants and agents who wish to avail of the PPH shall duly accomplish the PPH Request Form herein attached as Annex B, and seasonably file the same.

Under the IPOP HL- JPO PPH Agreement, JPO work products shall serve as additional reference by the IPOP HL Examiners.

For guidance.

  
**ATTY. RICARDO R. BLANCAFLOR**  
Director General

Republic of the Philippines  
INTELLECTUAL PROPERTY OFFICE  
Intellectual Property Centre, World Finance Plaza, 28 Upper McKinley Road,  
McKinley Hill Town Center, Fort Bonifacio, Taguig City, Philippines 1634  
• www.ipophil.gov.ph • T: +632-2386300 • F: +632-8569293 • mail@ipophil.gov.ph

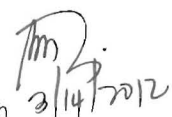
  
3/14/2012

## **Procedures to file a request to the IPOPHL (Intellectual Property Office of the Philippines) for Patent Prosecution Highway Pilot Program between the IPOPHL and the JPO (Japan Patent Office)**

### **Part I**

#### **PPH using the national work products from the JPO**

Applicants can request accelerated examination by a prescribed procedure including submission of relevant documents on an application which is filed with the IPOPHL and satisfies the following requirements under the IPOPHL-JPO Patent Prosecution Highway (PPH) pilot program based on the JPO application.

When filing a request for the PPH pilot program, an applicant must submit a request form to the IPOPHL.

The Offices may terminate the PPH pilot program if the volume of participation exceeds manageable level, or for any other reason. Ex Ante notice will be published if the PPH pilot program is terminated.

The PPH pilot program will be in effect for three (3) years commencing on March 12, 2012 and will end on March 11, 2015. However, the program may be extended after a joint IPOPHL-JPO review and assessment of the program implementation.

#### **1. Requirements**

- (a) *The IPOPHL application (including a PCT national phase application) is***
- (i) *an application which validly claims priority under the Paris Convention to the JPO application(s) (examples are provided in ANNEX I, Figure A, B, C, F, G and H), or***
  - (ii) *a PCT national phase application without priority claim (examples are provided in Annex I, Figure I), or***
  - (iii) *an application which validly claims priority under the Paris Convention to the PCT application(s) without priority claim (examples are provided in ANNEX I, Figure J, K and L).***

The IPOPHL application, which validly claims priority to multiple JPO or direct PCT applications, or which is the divisional application validly based on the originally filed application that is included in (i) to (iii) above, is also eligible.

- (b) *At least one corresponding application exists in the JPO and has one or more claims that are determined to be patentable/allowable by the JPO.***

The corresponding application(s) can be the application which forms the basis of the priority claim, an application which derived from the JPO application which forms the basis

of the priority claim (e.g., a divisional application of the JPO application or an application which claims domestic priority to the JPO application (see Figure C in Annex I)), or an JPO national phase application of a PCT application (see Figures H, I, K and L in Annex I).

Claims are “determined to be allowable/patentable” when the JPO examiner clearly identified the claims to be allowable/patentable in the latest office action, even if the application is not granted for patent yet.

The office action includes:

- (a) Decision to Grant a Patent
- (b) Notification of Reasons for Refusal
- (c) Decision of Refusal
- (d) Appeal Decision

For example, if the following routine expression is described in the “Notification of Reason for Refusal” of the JPO, those claims are clearly identified to be allowable/patentable.

<Claims which has been found no reason for refusal>

At present for invention concerning Claim\_\_\_, no reason for refusal is found.”

- (c) All claims on file, as originally filed or as amended, for examination under the PPH must sufficiently correspond to one or more of those claims indicated as allowable in the JPO.**

Claims are considered to “sufficiently correspond” where, accounting for differences due to translations and claim format, the claims in the IPOPHL are of the same or similar scope as the claims in the JPO, or the claims in the IPOPHL are narrower in scope than the claims in the JPO. In this regard, a claim that is narrower in scope occurs when a JPO claim is amended to be further limited by an additional feature that is supported in the specification (description and/or claims).

A claim in the IPOPHL which introduces a new/different category of claims to those claims indicated as allowable in the JPO is not considered to sufficiently correspond. For example, where the JPO claims only contain claims to a process of manufacturing a product, then the claims in the IPOPHL are not considered to sufficiently correspond if the IPOPHL claims introduce product claims that are dependent on the corresponding process claims. Any claims amended or added after the grant of the request for participation in the PPH pilot program need not to sufficiently correspond to the claims indicated as allowable in the JPO application.

- (d)** A request for PPH may be submitted even during the substantive examination stage, provided that, examination on the merits of the application has not been made.



## **2. Documents to be submitted**

Documents (a) to (d) below must be submitted by attaching to the PPH request.

- (a) Copies of all office actions (which are relevant to substantial examination for patentability in the JPO) which were issued for the corresponding application by the JPO, and translations of them<sup>1</sup>.**

Either Filipino or English is acceptable as translation language. The applicant does not have to submit a copy of JPO office actions and translations of them when those documents are provided via AIPN (JPO's dossier access system) because the office actions and their machine translations are available for the IPOPHL examiner via the AIPN. If they cannot be obtained by the IPOPHL examiner via the AIPN, the applicant may be notified and requested to provide the necessary documents.

- (b) Copies of all claims determined to be patentable/allowable by the JPO, and translations of them.**

Either Filipino or English is acceptable as translation language. The applicant does not have to submit a copy of claims indicated to be allowable/patentable in the JPO, and translations thereof when the documents are provided via AIPN (JPO's dossier access system) because they are available for the IPOPHL examiner via the AIPN. If they cannot be obtained by the IPOPHL examiner via the AIPN, the applicant may be notified and requested to provide the necessary documents.

- (c) Copies of references cited by the JPO examiner**

If the references are patent documents, the applicant doesn't have to submit them because the IPOPHL usually possesses them. When the IPOPHL does not possess the patent document, the applicant has to submit the patent document at the examiner's request. Non-patent literature must always be submitted.

The translations of the references are unnecessary.

- (d) Claim correspondence table**

The applicant requesting PPH must submit a claim correspondence table, which indicates how all claims in the IPOPHL application sufficiently correspond to the patentable/allowable claims in the JPO application.

When claims are just literal translation, the applicant can just write down that "they are the same" in the table. When claims are not just literal translation, it is necessary to explain the

---

<sup>1</sup> Machine translations will be admissible, but if it is impossible for the examiner to understand the outline of the translated office action or claims due to insufficient translation, the examiner can request the applicant to resubmit translations.



sufficient correspondence of each claim.

When the applicant has already submitted above documents (a) to (d) to the IPOPHL through simultaneous or past procedures, the applicant may incorporate the documents by reference and does not have to attach them.

### **3. PPH request form**

Subject: Request for an accelerated examination under the PPH pilot program

Date of filing: \_\_\_\_\_

Application number: \_\_\_\_\_

Title of the invention: \_\_\_\_\_

Applicant: \_\_\_\_\_

This application is an application validly claiming the priority under the Paris Convention to the corresponding JPO application (the application number is \_\_\_\_\_), and the accelerated examination is requested under the PPH pilot program. For this purpose, the following documents are attached:

- Copies of all office actions (which are relevant to substantial examination for patentability in the JPO) which were issued for the corresponding application by the JPO and  
 translations of them
  
- Copies of all claims determined to be patentable/allowable by the JPO and  
 translations of them
  
- Copies of references cited by the JPO examiner
  
- Claim correspondence table

Claim correspondence table		
The claim in the IPOPHL	The patentable claim in the JPO	Comments about the correspondence

(Documents to be omitted to submit)

---

---

---

## Part II

### PPH using the PCT international work products from the JPO

Applicants can request accelerated examination by a prescribed procedure including submission of relevant documents on an application which is filed with the IPOP HL and satisfies the following requirements under the IPOP HL-JPO Patent Prosecution Highway pilot program based on PCT international work products (PCT-PPH pilot program).

When filing a request for the PCT-PPH pilot program, an applicant must submit a request form to the IPOP HL.

The Offices may terminate the PCT-PPH pilot program if the volume of participation exceeds a manageable level, or for any other reason. Ex Ante notice will be published if the PPH pilot program is terminated.

The PPH pilot program will be in effect for three (3) years commencing on March 12, 2012 and will end on March 11, 2015. However, the program may be extended after a joint IPOP HL-JPO review and assessment of the program implementation.

#### 1. Requirements

The application which is filed with the IPOP HL and on which the applicant files a request under the PCT-PPH must satisfy the following requirements:

- (1) The latest work product in the international phase of a PCT application corresponding to the application (“international work product”), namely the Written Opinion of International Search Authority (WO/ISA), the Written Opinion of International Preliminary Examination Authority (WO/IPEA) or the International Preliminary Examination Report (IPER), indicates at least one claim as patentable/allowable (from the aspect of novelty, inventive steps and industrial applicability).**

Note that the ISA and the IPEA which produced the WO/ISA, WO/IPEA and the IPER are limited to the JPO, but, if priority is claimed, the priority claim can be to an application in any Office, see example A' in Annex II (application ZZ can be any national application).

The applicant cannot file a request under PCT-PPH on the basis of an International Search Report (ISR) only.

In case any observation is described in Box VIII of WO/ISA, WO/IPEA or IPER which forms the basis of a PCT-PPH request, the applicant must explain why the claim(s) is/are not subject to the observation irrespective of whether or not an amendment is submitted to correct the observation noted in Box VIII. The application will not be eligible for participating in PCT-PPH pilot program if the applicant does not explain why the claim(s) is/are not subject to the observation. In this regard, however, it does not affect the decision on the eligibility of the application whether the explanation is adequate and/or whether the amendment submitted



overcomes the observation noted in Box VIII.

- 2) The relationship between the application and the corresponding international application satisfies one of the following requirements:**
- (A) The application is a national phase application of the corresponding international application. (See Figures A, A', and A'' in Annex II)**
  - (B) The application is a national application as a basis of the priority claim of the corresponding international application. (See Figure B in Annex II)**
  - (C) The application is a national phase application of an international application claiming priority from the corresponding international application. (See Figure C in Annex II)**
  - (D) The application is a national application claiming foreign/domestic priority from the corresponding international application. (See Figure D in Annex II)**
  - (E) The application is the derivative application (divisional application and application claiming domestic priority etc.) of the application which satisfies one of the above requirements (A) – (D). (See Figures E1 and E2 in Annex II)**
- (3) All claims on file, as originally filed or as amended, for examination under the PCT-PPH must sufficiently correspond to one or more of those claims indicated as allowable in the latest international work product of the corresponding international application.**

Claims are considered to "sufficiently correspond" where, accounting for differences due to translations and claim format, the claims in the IPOPHL are of the same or similar scope as the claims indicated as allowable in the latest international work product, or the claims in the IPOPHL are narrower in scope than the claims indicated as allowable in the latest international work product.

In this regard, a claim that is narrower in scope occurs when a claim indicated as allowable in the latest international work product is amended to be further limited by an additional feature that is supported in the specification (description and/or claims).

A claim in the IPOPHL which introduces a new/different category of claims to those claims indicated as allowable in the latest international work product is not considered to sufficiently correspond. For example, where the claims indicated as allowable in the latest international work product only contain claims to a process of manufacturing a product, then the claims in the IPOPHL are not considered to sufficiently correspond if the IPOPHL claims introduce product claims that are dependent on the corresponding process claims.

Any claims amended or added after the grant of the request for participation in the PCT-PPH pilot program need not to sufficiently correspond to the claims indicated as allowable in the latest international work product.

- (4) A request for PPH may be submitted even during the substantive examination stage, provided that, examination on the merits of the application has not been made.

## **2. Documents to be submitted**

The applicant must submit the following documents attached to the request form in filing a request under PCT-PPH. Some of the documents may not be required to submit in certain cases.

- (1) A copy of the latest international work product which indicated the claims to be patentable/allowable and their Filipino or English translations if they are not in English.**

In case the application satisfies the relationship 1.(2)(A), the applicant need not submit a copy of the International Preliminary Report on Patentability (IPRP) and any English translations thereof because a copy of these documents is already contained in the file-wrapper of the application. In addition, if the copy of the latest international work product and the copy of the translation are available via "PATENTSCOPE (registered trademark)"<sup>2</sup>, an applicant need not submit these documents, unless otherwise requested by the IPOPHL.

(WO/ISA and IPER are usually available as "IPRP Chapter I" and "IPRP Chapter II" respectively in 30 months after the priority date.)

- (2) A copy of a set of claims which the latest international work product of the corresponding international application indicated to be patentable/allowable and their Filipino or English translations if they are not in English**

If the copy of the set of claims which are indicated to be patentable/allowable is available via "PATENTSCOPE (registered trademark)" (e.g. the international Patent Gazette has been published), an applicant need not submit this document unless otherwise requested by the IPOPHL. Where the set of claims is written in Japanese, the translations thereof must be still submitted by an applicant.

- (3) A copy of references cited in the latest international work product of the international application corresponding to the application.**

If the reference is a patent document, the applicant is not required to submit it. In case the IPOPHL has difficulty in obtaining the document, however, the applicant may be asked to submit it. Non-patent literature must always be submitted. Translations of cited references are unnecessary.

---

<sup>2</sup> <http://www.wipo.int/pctdb/en/index.jsp>

**(4) A claims correspondence table which indicates how all claims in the application sufficiently correspond to the claims indicated to be patentable/allowable.**

When claims are just literal translation, the applicant can just write down that “they are the same” in the table. When claims are not just literal translation, it is necessary to explain the sufficient correspondence of each claim based on the criteria 1. (3) (Please refer to the Example form below).

When an applicant has already submitted the above mentioned documents (1) - (4) to the IPOPHL through simultaneous or past procedures, the applicant may incorporate the documents by reference and is thus not required to attach the documents.

**3. PCT-PPH request form**

Subject: Request for an accelerated examination under the PCT-PPH pilot program

Date of filing: \_\_\_\_\_

Application number: \_\_\_\_\_

Title of the invention: \_\_\_\_\_

Applicant: \_\_\_\_\_

This application is a national phase application of a PCT international application (the application number is \_\_\_\_\_), and the accelerated examination is requested under the PCT-PPH pilot program. For this purpose, the following documents are attached:

- A copy of the latest international work product which indicated the claims to be patentable/allowable and
- their Filipino or English translations if they are not in English
  
- A copy of a set of claims which the latest international work product of the corresponding international application indicated to be patentable/allowable and
- their Filipino or English translations if they are not in English
  
- A copy of references cited in the latest international work product of the international application corresponding to the application
  
- A claims correspondence table which indicates how all claims in the application sufficiently correspond to the claims indicated to be patentable/allowable



Claim correspondence table		
The claim in the IPOPHL	The patentable claim in the international phase	Comments about the correspondence

(Documents to be omitted to submit)

---

---

---

**A** A case meeting requirement (a) (i)  
- Paris route -

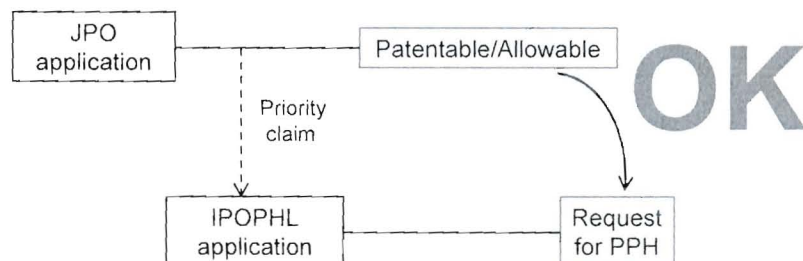

**B** A case meeting requirement (a) (i)  
- PCT route -

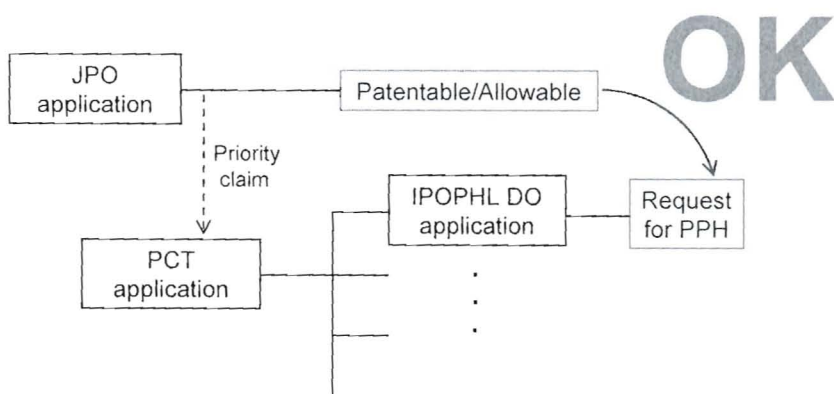

**C**

A case meeting requirement (a) (i)

- Paris route, Domestic priority -

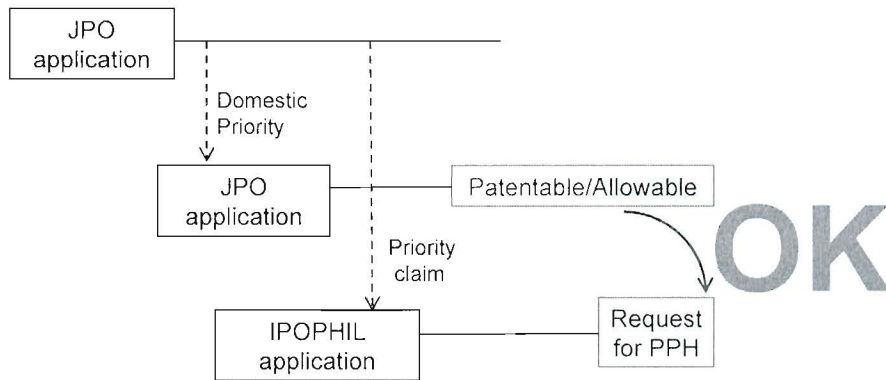

**D**

A case not meeting requirement (a)

- Paris route, but the first application is from the third country -

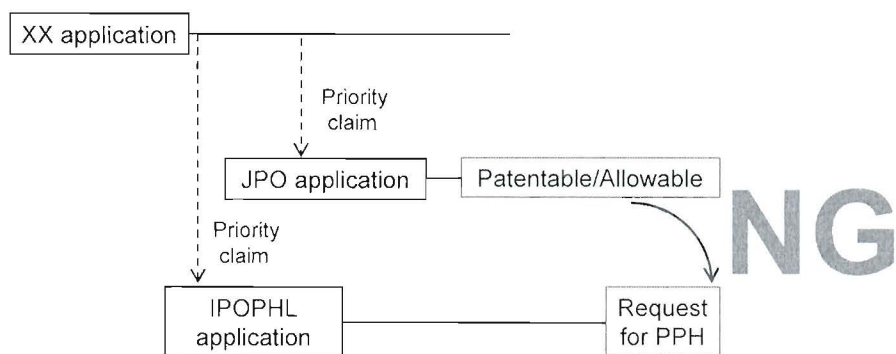

XX : the office other than the JPO



**E** A case not meeting requirement (a)  
- PCT route, but the first application is from the third country -

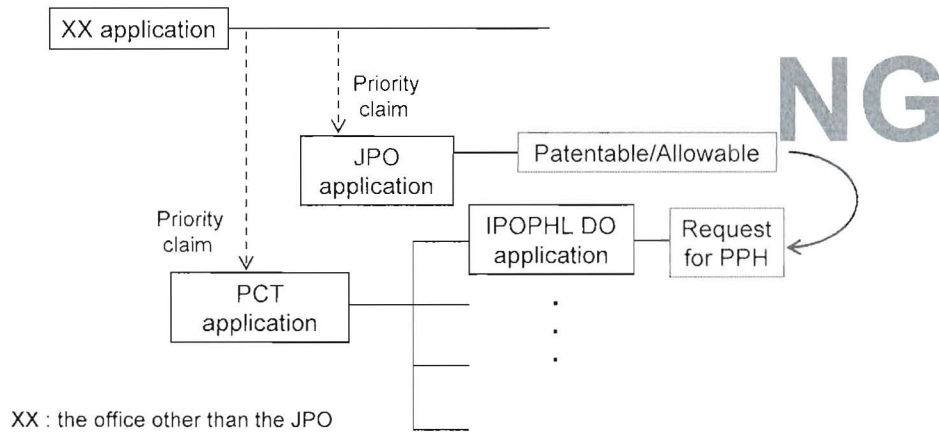

**F** A case meeting requirement (a) (i)  
- Paris route & Complex priority -

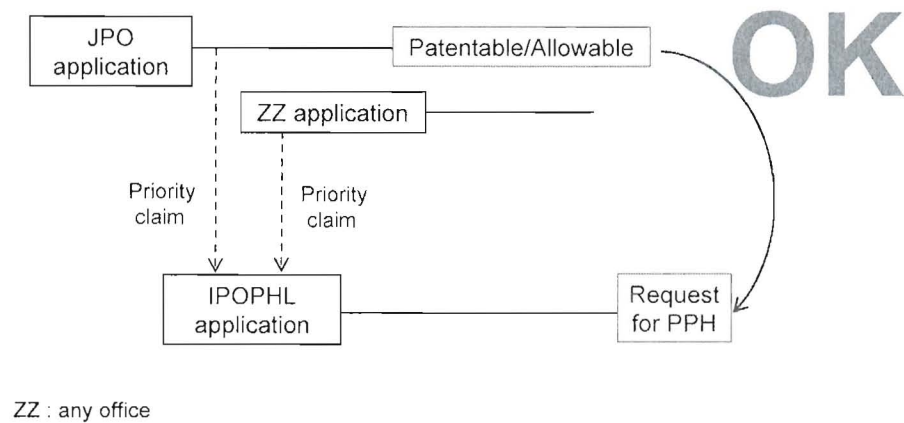

**G** A case meeting requirement (a) (i)  
- Paris route & divisional application -

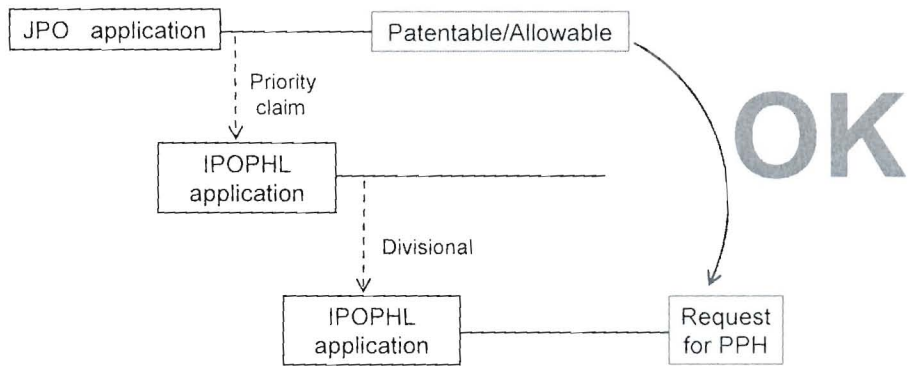

**H** A case meeting requirement (a) (i)  
- PCT route -

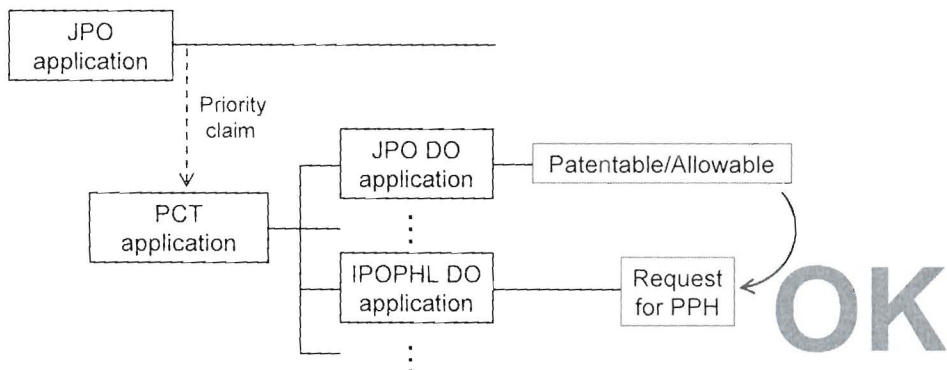

**I** A case meeting requirement (a) (ii)  
- Direct PCT route -

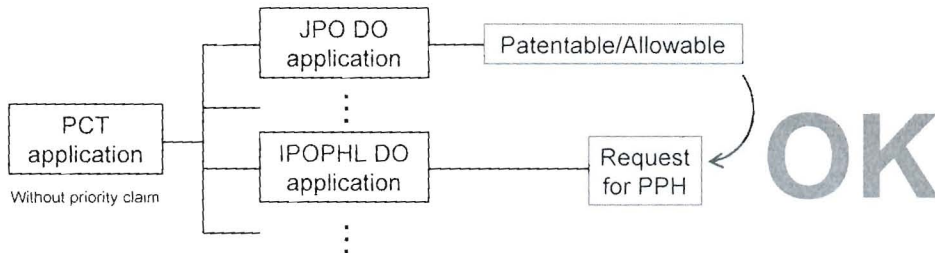

**J** A case meeting requirement (a) (iii)  
- Direct PCT & Paris route -

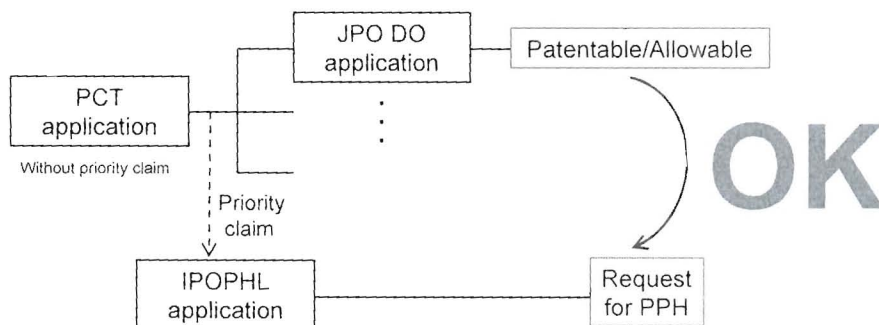



**K** A case meeting requirement (a) (iii)  
- Direct PCT & PCT route -

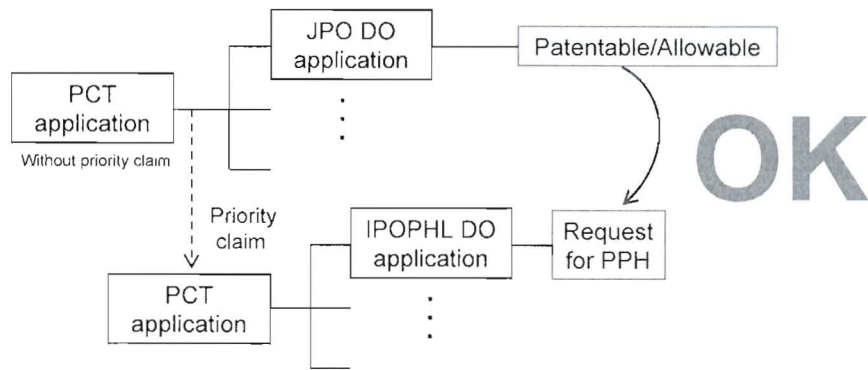

**L** A case meeting requirement (a) (iii)  
- Direct PCT & PCT route -

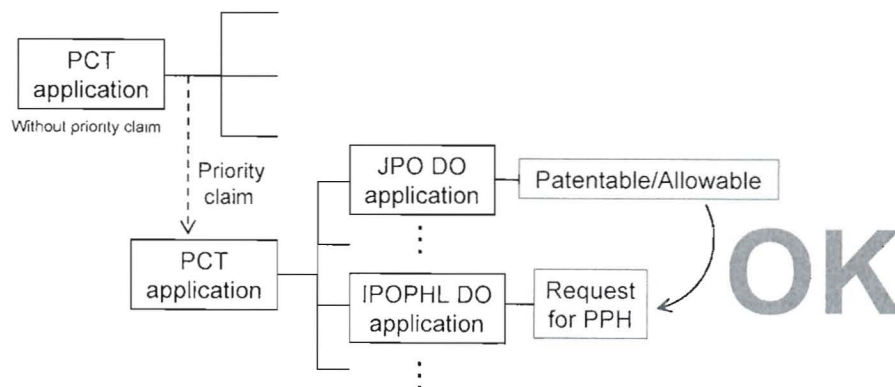

**(A) The application is a national phase application of the corresponding international application.**

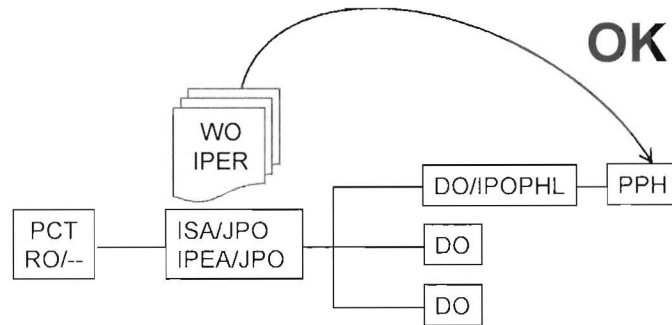

**(A') The application is a national phase application of the corresponding international application.**

**(The corresponding international application claims priority from a national application.)**

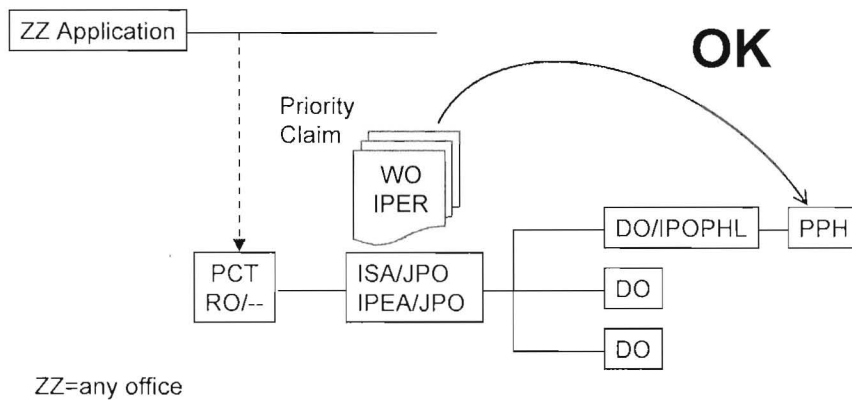

**(A'') The application is a national phase application of the corresponding international application.**

**(The corresponding international application claims priority from an international application.)**

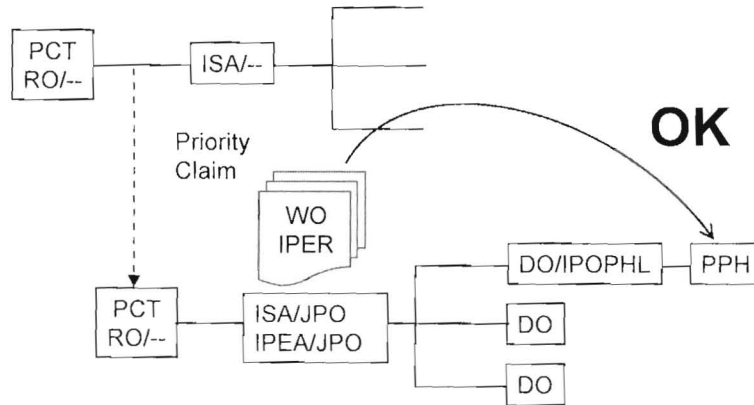

**(B) The application is a national application as a basis of the priority claim of the corresponding international application.**

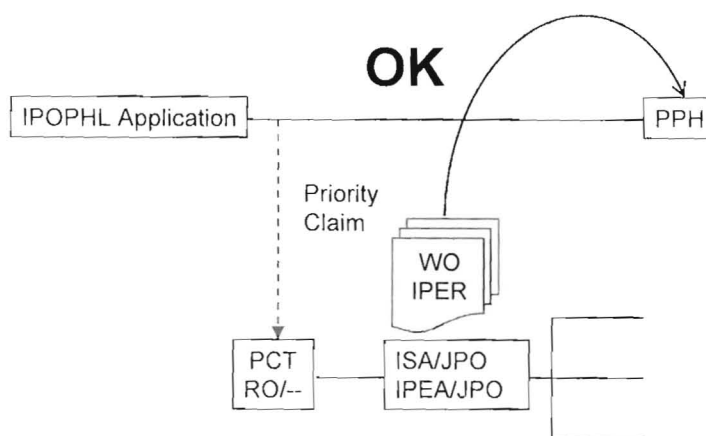

(C) The application is a national phase application of an international application claiming priority from the corresponding international application.

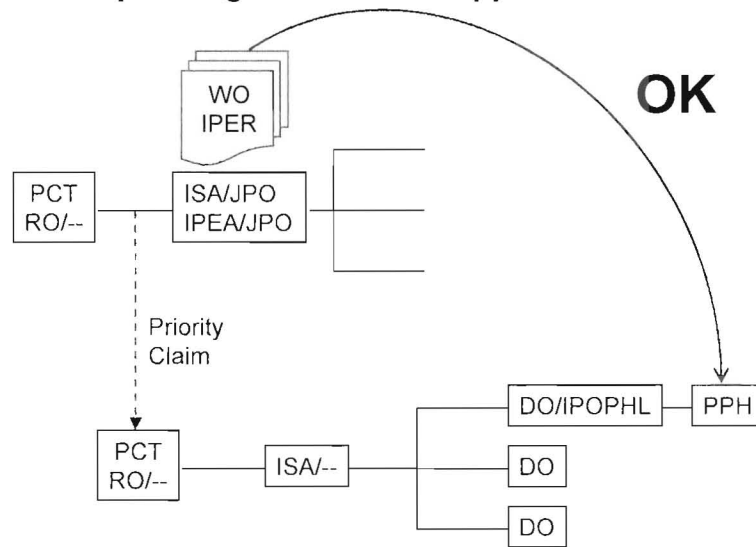

(D) The application is a national application claiming foreign/domestic priority from the corresponding international application.

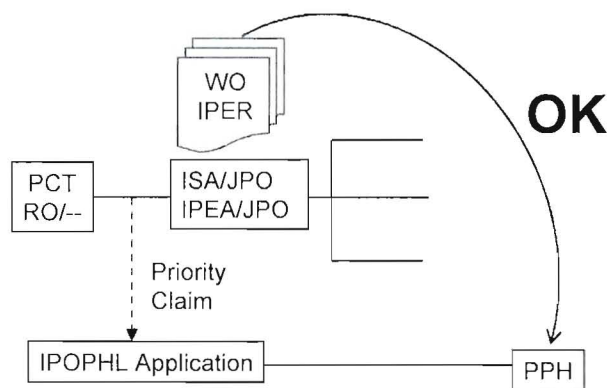

**(E1) The application is a divisional application of an application which satisfies the requirement (A).**

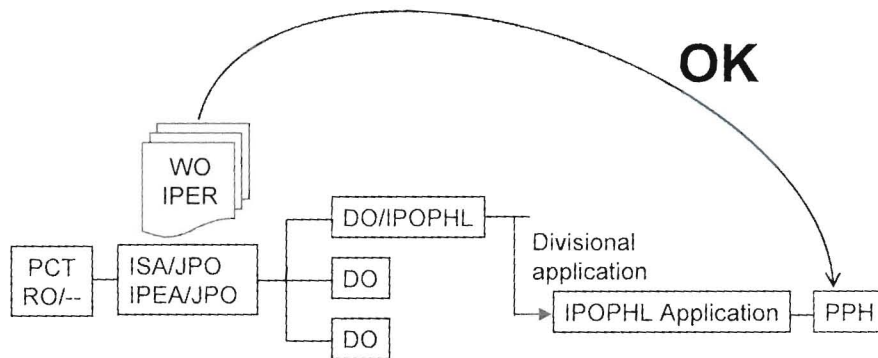

**(E2) The application is an application claiming domestic priority from an application which satisfies the requirement (B).**

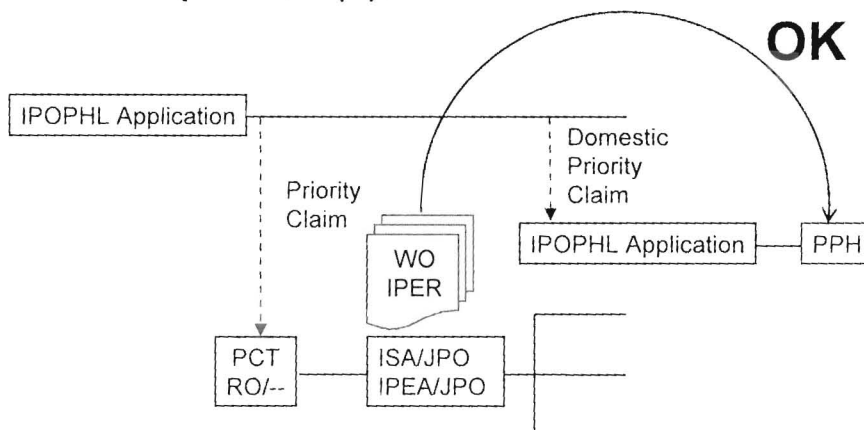



## JPO-IPOPHL PATENT PROSECUTION HIGHWAY (PPH) REQUEST FORM

---

<b>APPLICATION NO.</b>	
<b>TITLE OF THE INVENTION</b>	
<b>APPLICANT</b>	
<b>CORRESPONDING JPO APPLICATION NO.</b>	
<b>DOCUMENTS SUBMITTED</b>	<input type="checkbox"/> Copies of all office actions (which are relevant to substantial examination for patentability in the JPO) which were issued for the corresponding application by the JPO <input type="checkbox"/> Translations of said office actions if not in English <input type="checkbox"/> Copy of all claims determined to be patentable/allowable by the JPO <input type="checkbox"/> Translations of said patentable/allowable claims if not in English <input type="checkbox"/> Copies of references cited by the JPO examiner <input type="checkbox"/> Claim correspondence table
<b>SIGNATURE/DATE</b>	
<i>For authorized receiving officer of IPOPHL only</i>	
<b>RECEIVING OFFICER</b>	
<b>DATE RECEIVED</b>	

**CLAIM CORRESPONDENCE TABLE**

<b>CLAIM(S) IN THE IPOPHL APPLICATION</b>	<b>PATENTABLE CLAIM(S) IN THE CORRESPONDING JPO APPLICATION</b>	<b>COMMENTS ABOUT THE CORRESPONDENCE</b>

**(Documents to be omitted to submit)**

## JPO-IPOPHL PCT-PATENT PROSECUTION HIGHWAY (PPH) REQUEST FORM

---

<b>APPLICATION NO.</b>	
<b>TITLE OF THE INVENTION</b>	
<b>APPLICANT</b>	
<b>CORRESPONDING PCT INTERNATIONAL APPLICATION NO.</b>	
<b>DOCUMENTS SUBMITTED</b>	<ul style="list-style-type: none"> <li><input type="checkbox"/> A copy of the latest international work product which indicated the claims to be patentable/allowable</li> <li><input type="checkbox"/> Translation of said latest international work product if not in English</li> <li><input type="checkbox"/> A copy of the set of claims which the latest international work product of the corresponding international application indicated to be patentable/allowable</li> <li><input type="checkbox"/> Translations of said patentable/allowable claims if not in English</li> <li><input type="checkbox"/> Copies of references cited in the latest international work product of the international application corresponding to the application</li> <li><input type="checkbox"/> Claim correspondence table</li> </ul>
<b>SIGNATURE/DATE</b>	
<i>For authorized receiving officer of IPOPHL only</i>	
<b>RECEIVING OFFICER</b>	
<b>DATE RECEIVED</b>	





## JPO-IPOPHL PATENT PROSECUTION HIGHWAY (PPH) INTERNAL WORKFLOW

