

Communicating Astronomy with the Public

What is Astronomy for Development?

Find out how astronomy outreach is contributing to improving livelihoods around the world

After-School Astronomy Education in Brazil

Setting up students for college against the odds

Astronomy for Peace

Finding commonalities through astronomy in Cyprus

International Astronomical Union Office of Astronomy for Development (IAU OAD) recently announced its recipients for 2020 project grants, selected through its annual Call for Proposals. Projects selected include an astronomy programme coupled with counselling sessions to support internally displaced children; various projects to inspire, stimulate, and educate children from poorer socio-economic backgrounds; an astrotourism project; and programmes aimed at the promotion of cultural astronomy and development of Indigenous peoples. The next call for proposals is expected to be announced in April 2020. Projects funded between 2013 and 2020 are shown as blue dots. Also on this map, denoted by orange dots, are the 11 Regional Offices of the IAU OAD, based in Armenia, China, Colombia, Ethiopia, Jordan, the Netherlands, Nigeria, Portugal, Thailand, Zambia and most recently the United States. These offices focus on particular geographic or cultural regions while working closely with the global IAU OAD to execute the vision of "Astronomy for a better world." Credit: IAU OAD/CARTO/OpenStreetMap Contributors/Stamen Designs

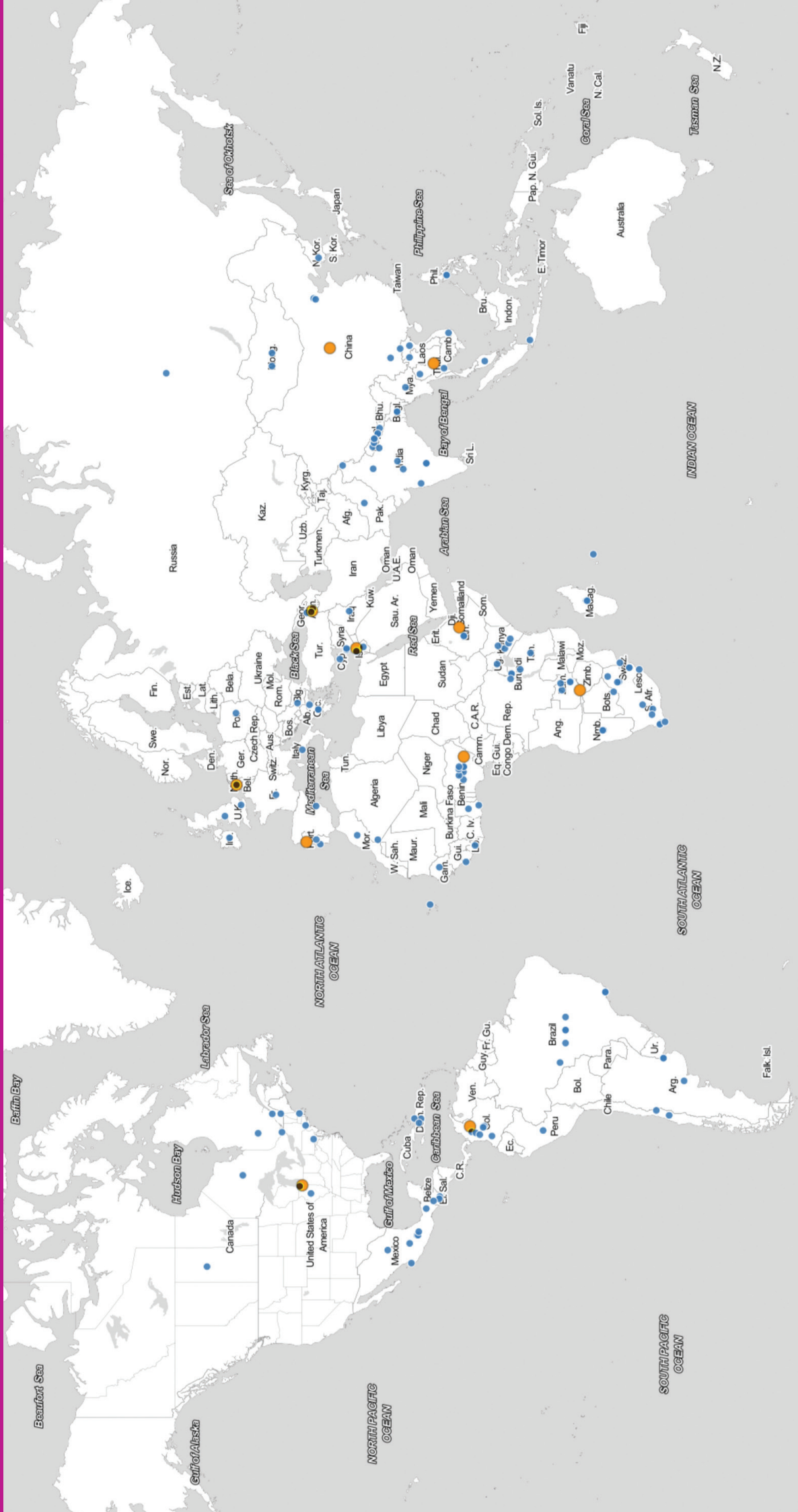

Guest Editorial

We are excited to bring you the first-ever special edition of the Communicating Astronomy with the Public Journal on "Astronomy for Development". For this 27th issue, the IAU Office of Astronomy for Development (OAD) collaborated with the CAPjournal to explore the contributions of astronomy outreach and communication to sustainable development.

While "Astronomy for Development" is a relatively recent term, coined and popularised in the last decade, the principles behind it have always had a close connection with astronomy communication. Astronomers, communicators and outreach professionals have engaged millions, potentially billions, of people in science and the scientific method, promoting education and the value of critical thinking. Many of these activities target audiences in disadvantaged areas, aiming to level the playing field in terms of opportunities available, skills development, and exposure to scientific astronomical knowledge.

The OAD, a joint partnership between the IAU and the National Research Foundation (NRF) of South Africa, has been coordinating development activities since 2011, by funding projects and working with regional offices, partners and collaborators. But we believe the Astronomy-for-Development community is much bigger than the OAD and considerably overlaps with the CAP community. We have gathered for this issue some of the creative and effective outreach projects and strategies employed by this global community to stimulate development. These include interventions which use astronomy to improve inclusion and gender equality, stimulate economies with astrotourism, reduce light pollution, promote education and tolerance, and more.

This issue also presents posters on OAD's new Flagship projects, which are large-scale development programs built on the successes and lessons of past OAD projects. Flagship 1 aims to use new and existing astronomical facility to stimulate socio-economic benefits (the article on AstroStays in "Explained in 60 Seconds" provides a great introduction) while Flagship 2 pulls from the inspirational grandeur of astronomy to stimulate a sense of tolerance and common humanity (read this excerpt from Carl Sagan's Pale Blue Dot on The Planetary Society website here: <https://bit.ly/2TaGfsw>).

We realise there are many more projects making an impact than we can cover in one or two or even ten editions of the CAPjournal. If you are running an Astronomy-for-Development project that is benefiting your community, we encourage you to contact us so we may share it with the larger community and the rest of the world. In the end, it is you, the community of practitioners, who are effecting change and we are extremely grateful to you for your continued efforts to make the world a better place.

Ramasamy Venugopal, on behalf of The IAU Office of Astronomy for Development team
Invited Guest Editors for CAPjournal #27

Cover: Observing with the Travelling Telescope at Chumani Secondary School, Kilifi, Kenya, 18 May 2015. Credit: IAU/the Travelling Telescope



Contents

Explained in 60 Seconds: Creating Sustainable Livelihoods Through AstroStays	4
Ad Astra Academy: Using Space Exploration to Promote Student Learning and Motivation in the City of God, Rio de Janeiro, Brazil	5
Astronomy as a Tool for Peace and Diplomacy: Experiences from the Columba-Hypatia Project	14
Astrotourism in The Mara	20
Dark Sky Sim: An Open-Design Dark Sky Simulator	24
Astronomy in Indigenous Communities	27
How Astronomers Perceive the Societal Impact of Research: An Exploratory Study	31
Highlights in the Implementation of the AstroBVI Project to Increase Quality Education and Reduce Inequality in Latin America	35
Astro Molo Mhlaba: A Sustainable Approach to Inclusivity in Astronomy	39

News

Resources

Best Practice

Column

Explained in 60 Seconds: Creating Sustainable Livelihoods Through Astrostays

Sonal Asgotraa

AstroStays
sonal@ghe.co.in

Paras Loomba

Global Himalayan Expedition (GHE)
paras@ghe.co.in

A lack of electricity, education and access to sustainable incomes are critical problems surrounding remote Himalayan communities. However, these regions have a powerful resource that had never been utilized to drive growth and positive change for these areas—their clear night skies.

With the aim of leveraging astronomy as a key developmental intervention, Global Himalayan Expedition (GHE), a social enterprise working in the Ladakh territory, partnered with International Astronomical Union Office of Astronomy for Development (IAU OAD), to create Astronomy for Himalayan Livelihood Creation (AHLC). This programme promotes astronomy to further develop the economy of the remote villages in Ladakh. The first project of AHLC is AstroStays.

The main objective behind AstroStays is to leverage astronomy to create sustainable livelihood opportunities for these remote communities. Astrostays

engages tourists in local culture, stories and heritage while travellers live in a homestay, which in turn generates benefits for the rural and remote region that has access to clear night skies. Communities are kept at the core of the programme—community members are equal stakeholders in the development of AstroStays. The inflow of money into the village economy alleviates everyone equally, and many women, in particular, are now more confident and handle family finances.

Since starting in June 2019, 30 women from 15 different villages have been trained on the basics of astronomy and how to operate a telescopes by scientists from the Indian Institute of Astrophysics (IIA). The first astrostay in Ladakh was set up in the village of Maan (4250 metres elevation), near the lake Pangong Tso. A team of five trained community members from Maan now use their new skills to conduct night sky viewing ses-

sions for the incoming tourists using a 10-inch telescope on a tracking mount. A second telescope has been installed in nearby Leh, in a partnership with PAGIR, an organisation working with specially-abled people of Ladakh. The five-member team has been similarly trained as the women to promote inclusive astrotourism.

There are now five astronomical homestays operational in Ladakh. In the last four months of operations, over 510 travellers have visited the astrostays, generating an additional income of around 1410 USD for the community and local entrepreneurs. Conducting night sky watching sessions and homestays for the incoming tourists has enabled communities to create new channels for generating revenue, while along the way fostering sustainable progress in the economy, gender equality, as well as scientific temperament in the region.



Figure 1. AstroStays Team in Ladakh. Credit: Global Himalayan Expedition (GHE)

Ad Astra Academy: Using Space Exploration to Promote Student Learning and Motivation in the City of God, Rio de Janeiro, Brazil

Wladimir Lyra

New Mexico State University
wlyra@nmsu.edu

Melissa Rice

Western Washington University
melissa.rice@wwu.edu

Dhyan Adler-Belendez

Harvard Graduate School of Education (alumnus)
dhyan@alumni.harvard.edu

Neil Jacobson

University of Southern California
ngjacobs@usc.edu

Ana Pantelic

University of Belgrade
anapantelic@gmail.com

Karolina Garcia

University of Florida
karolina.garcia@ufl.edu

Leonardo Sattler Cassara

Federal University of Rio de Janeiro
leocassara@igeo.ufrj.br

Carolyn Crow

University of Colorado Boulder
carolyn.crow@colorado.edu

Paul Hayne

University of Colorado Boulder
paul.hayne@lasp.colorado.edu

Jeffrey Marlow

Boston University
jjmarlow@bu.edu

Keywords

Astronomy education; Student motivation; Mars exploration; Astrobiology; Outreach for Development

Motivation is a primary determinant of a student's academic success, but in many under-resourced educational contexts around the world, opportunities to develop motivation are lacking. In the City of God neighborhood of Rio de Janeiro, Brazil, we, a group of scientists and science educators, enacted the Ad Astra Academy, a brief, interactive intervention targeting teenage students at risk of dropping out of school. Students participated in an immersive five-day programme, followed by a six-month lecture series, before completing the second, immersive three-day programme. Participants learned how to use the scientific method in real-world settings to generate new knowledge. In order to consolidate these knowledge gains and bolster the inspirational power of the programme, capstone projects empowered participants to speak with NASA mission managers and, in some cases, acquire never-before-seen images of Mars. While longitudinal study and a more robust sample size are required to bolster conclusions about the efficacy of our approach, initial results suggest that Ad Astra programmes significantly enhance self-efficacy and science-oriented career ambitions.

Introduction

Among the factors that are positively correlated with academic success, motivation is paramount: with an intrinsic desire to learn, students are better positioned to overcome obstacles and make the most of available opportunities (Linnenbrink-Garcia, 2016). Anecdotal evidence among practising scientists suggests that specific, punctuated events during childhood can spark academic interest and sustain motivation (Heddy & Sinatra, 2013). The Ad Astra Academy aims to develop such experiences for students in under-resourced educational contexts in order to inspire them to pursue further education, even in the face of structural obstacles. As an organisation led by scientists, it also measures the results of its activities and anal-

yses the degree to which focused interventions can have behavioural, academic and career-based effects on participants. Astronomy, astrobiology and space exploration represent compelling subject matter for these efforts because of the sense of wonder, awe, inspiration and other positive emotions that they can instil, especially among youth, and also due to the wide-reaching, universal questions they engage (Valdesolo, 2016). By presenting scientific content in the framework of exploration and discovery, Ad Astra programmes incorporate principles of active learning and team-based projects, placing the student at the center of the learning process and encouraging autonomous learning, thereby providing the opportunity to display resilience, competence and cooperation (Fernandez-Rio, 2017).

Some factors that contribute to student motivation are relatively well-established. Past work has demonstrated the importance of competence, autonomy, and relatedness through the framework of self-determination theory (Deci & Ryan, 2000), revealing the benefits of metacognition to keep track of progress (Zepeda, 2015) and highlighting the value of a growth mindset in building resilience and sustained academic interest (Dweck, 2016). Similarly, the expectancy-value theory (Wigfield & Eccles, 2000) has shown that students' achievement on a task depends on the subjective value that students assign to it, and whether they expect to succeed.

Most of these and other studies on motivation focus on structural or attitudinal factors; here, we seek to analyse how factors

such as brevity and intensity of an intervention can lead to long-lasting motivational changes. Simply put: Can a brief, dramatic experience substantially change the nature of a student's motivation, and thereby positively influence their career trajectory? Several authors point to a class of brief interventions that have a long-lasting effect months and even years after they end (Yeager & Walton, 2011; Walton, 2014). Most of these studies emphasise that long-term effects were detected, but we aim to explore the factors that make this possible. In particular, we are interested in empirically investigating the role that astronomy, astrobology and space exploration can play in building and sustaining motivation—and in ultimately influencing socio-economic development outcomes.

Here, we present qualitative and exploratory quantitative results from two Ad Astra Academy programmes that spanned four years (2015 and 2018) in the City of God neighborhood of Rio de Janeiro, Brazil. Our after-school programme integrated classroom-based lectures, interactive exercises, full-day field trips outside the city, and immersive Capstone Projects involving active NASA missions. The Ad Astra Academy team included an “international team” (consisting of American and Brazilian scientists and educators who work at US institutions) in conjunction with a “local team” (consisting of Brazilian scientists and educators who work in Rio de Janeiro). The international team brought a breadth of astronomy and astrobology expertise and direct connections to active NASA exploration missions and the local team fostered effective communication and featured more relatable role models for participating students. While the international and local teams were not identical between 2015 and 2018, the total number of facilitators and the number of English vs Portuguese speakers were the same. We are interested in investigating how the complementary roles of the international and local teams influenced the outcomes of the programmes and student motivation. From the assessment of the implementation and learning outcomes of the Ad Astra Academy programmes, our goal is to identify a set of best practices that can we recommend for implementing brief, intense interventions to enhance student motivation in under-resourced communities.

Motivation and Setting

The Ad Astra Academy set out to improve the academic experiences of disadvantaged youth through an alternative approach to learning through exploration. In Rio de Janeiro, Brazil, the “favelas” are neighborhoods with high concentrations of people living in poverty, with high levels of criminal activity and limited professional opportunities for young people. It has been shown that, in Brazil, every additional year of education results in a nearly 15% increase in wages, making education one of the most powerful drivers of economic success (Psacharopoulos & Patrinos, 2004). However, the unbalanced education system in Brazil means that the poor have few prospects for social mobility, and children growing up in favelas are at a significant disadvantage. Admission rates to the best universities are extremely low, and enrolment is determined by a selection exam that privileges well-resourced students. According to the Brazilian Institute of Geography and Statistics (IBGE), in 2014 the government calculated that 40% of the students in the top-ranked federal public universities were from the richest quintile of the population, while the poorest quintile represented around 7% of enrolment (IBGE, 2015). While the situation has improved significantly (from 60% and 2%, respectively, in 2004), the conclusion is unavoidable: Students from under-resourced communities face major barriers in their pursuit of higher education and social mobility.

In Rio de Janeiro alone, two million *favela* residents (which accounts for nearly one-third of the city population) are virtually excluded from university-level education. Data from IBGE show that educational trajectories are largely established in secondary school: 30% of 15- to 17-year-olds in the poorest quintile of the population have abandoned school. In contrast, the dropout rate among the richest quintile of the same age range is only 5% (IBGE).

Social challenges compound the problem. As university and job prospects become unrealized dreams in the favela, other forces take hold. According to 2018 data from the World Health Organization (WHO), Brazil had one of the highest rates of teenage pregnancy in the world (60.8 births per 1000 girls, which was more than six times

higher than the rate for high-income countries that are part of the Organisation for Economic Co-operation and Development (OECD)) (WHO, 2018). For boys, the timing of school dropouts coincides with recruitment into drug-related gangs, which target teenagers. According to 2015 Brazilian government statistics, of all arrests made nationwide in Brazil, 18% were of boys under the age of 18, and 41% of these arrests were due to drug-trafficking activities (Brasília: Presidência da República, 2015).

In short, there are enormous obstacles to professional success for children growing up in the *favelas* of Rio de Janeiro, and we hypothesize that a strong sense of intrinsic motivation instilled through a brief but exciting intervention could provide positive momentum to help students overcome the circumstances they were born into. The Ad Astra Academy sought to engage students right before the critical age of adolescence when Brazilian teenagers in the City of God are most likely to abandon their education. We partnered with the Instituto Presbiteriano Álvaro Reis (INPAR), a 100-year-old institution that facilitates extra-curricular activities for the youth of the *favela*¹. The Ad Astra Academy team also coordinated activities for student participants with the Museum of Astronomy, the City Planetarium, the Museum of Life, and the Valongo Observatory at the Federal University of Rio de Janeiro (UFRJ).

Programme Description

In collaboration with coordinators at INPAR, we selected cohorts of 20 students between the ages of 12 to 16 years old to participate in each of two programmes in 2015 and 2018. The same criterion was used to choose participants in both years. Initial school-directed selections consisted of the top-performing students (80% female, 20% male)²; in this context, the programme was presented as a reward for good academic performance. However, in order to fulfill our central aim of engaging students for whom the traditional school system was not working, classes were adjusted to add several boys who were interested in astronomy but were less academically engaged², as these boys face higher risks of being recruited by drug-related gangs.

This shift resulted in a 50%-50% male to female ratio. Both cohorts consisted of heterogeneous groups covering a spectrum of academic interest and susceptibility to dropping out of school. By diversifying the sampling parameters, the Academies were designed to provide a springboard of positive reinforcement for curious students who lacked engaging academic experiences, and also to show students on less productive paths that learning could be an exciting activity with long-term benefits at a key inflection point in their lives.

The curriculum and structure of the programmes were aligned with self-determination theory which specifies the importance of autonomy, competence and relatedness (Deci & Ryan, 2000). To support student autonomy, we incorporated self-directed learning and viewed learners as active constructors of their knowledge. To support competence, we engaged deeply with content knowledge and procedural knowledge of the scientific method. Finally, to bolster relatedness, we invited local scientists to speak about their research experiences in astronomy and to share their

perspectives on how science can work in concert with community goals and values. Details of the programmes (a summary of daily activities, learning objectives and relation to Bloom's Taxonomy of cognition) are provided in Table 1⁵). The learning and teaching designs for the 2015 and 2018 programmes were similar, although the 2015 programme included two weeks of intense classroom intervention, and the 2018 programme was condensed to a single week.

Programme One: 2015

The inaugural Ad Astra Academy programme in 2015 consisted of two separate sessions: five days in June and three days in November. Prior to the start of any programmatic activities, students were given a pre-test (see "Outcomes" section), administered by INPAR staff. In preparation for the first visit from the international team, INPAR took the students on visits to the Museum of Astronomy and the City Planetarium, both in Rio de Janeiro. These initial activities primed the students for the start of the curriculum with fundamental

knowledge of space-related subject matter and build a sense of excitement for "school not-as-usual."

Two week-long visits from the international team were separated by six months (Table 1). During the first session, the goal was to introduce the students to the process of scientific investigation, to ensure they had an adequate knowledge base to perform the Capstone Project, and to engage the students with the excitement of exploration. This was achieved through a combination of presentations, hands-on activities, and a field trip. While time spent lecturing was generally kept to a minimum, one of the local team members presented an overview of scientists from Brazil who had made significant contributions, showing the students how members of their own community have contributed to important scientific discoveries, thereby making the idea of becoming a scientist more accessible (Brown, 2015).

By positioning a field trip on the second day of the programme, we anticipated positive out-of-classroom team-building effects that would be sustained for the rest of the programme. The field trip during the first session was to Jaguanum Island—a 3 km² island off the Green Coast of Rio de Janeiro about two hours from the school—which included a trip on a chartered "pirate ship." During the trip, students gained an introduction to field-based science and analysis. The following day, students connected discussions of habitability and life across wide spatial scales, using microscopes and satellite imagery via Google Earth. In the final two days of the first week, students completed activities to prepare them for the Capstone Project, in which teams of students identified sites on Mars where they would request high-resolution images to be acquired from NASA's *Mars Reconnaissance Orbiter (MRO) High Resolution Imaging Science Experiment (HiRISE)* instrument. Using all they had learned about habitability and geomorphology thus far, student teams provided three scientifically-supported reasons to justify their requests for *HiRISE* images. In a live video call with *HiRISE* mission team members at the control centre in Arizona, US, students made their case that the proposed images would provide helpful new information about Mars' past or present conditions.



Figure 1. Model Mars rover building activity during the 2018 programme, with starting materials (a) and students assembling rovers in teams together with Ad Astra instructors (b-d). Credit: Ad Astra Academy

Between the first and second visits of the international team, the local team made weekly presentations to the students at INPAR on different topics in astronomy. These events were essential to keep the students engaged and motivated to continue the programme during the next international team visit. In November 2015, the international team reconnected with the students, and, on the first day, ceremoniously revealed large-format posters of the student-requested *HiRISE* images (Figure 3). (Three of the six requested images were acquired, thanks to the invaluable support of the *HiRISE* team.) On the second day, the students went on a full-day field trip to the Tijuca Forest, the largest urban forest in the world, to connect themes of habitability, landscape formation processes, and *HiRISE* images of Mars. On the final day of the programme, student teams used their *HiRISE* images as a platform for a mock Mars rover mission. Students took turns as “Mission Manager”, proposing sites to investigate and types of data to collect. This exercise, which required teamwork skills of negotiation and debate while using well-supported justification, reflected many of the challenges of real-world projects. By requiring a consensus for each round of exploration and ensuring that each student had a turn at the helm, interpersonal dynamics were surprisingly cooperative. At the programme’s conclusion, students completed a post-test, identical to the pre-test, to enable programme evaluation.

Programme Two: 2018

Due to time constraints and budget optimisation efforts, the second programme was conducted over a single week in July 2018, allowing us to test a different Capstone Project. The first three days of the curriculum were identical to that of the 2015 programme, building familiarity with the scientific method, highlighting the joy of exploratory field observation, and connecting observations across wide spatial scales using microscopes and satellite imagery.

The Capstone Project, which occupied days four and five, centered around the use of real Mars rover mission data to plan scientific investigations of a Martian crater’s habitability and ancient environmental conditions. Rather than generate primary data themselves (as had been done via *HiRISE* image acquisition in 2015), stu-

dents analysed real NASA *Mars Science Laboratory (MSL)* images and developed science plans based on well-supported hypotheses. They built small model rovers to understand fundamental engineering and design principles (Figure 2), and ultimately pitched their rover traverse plans via videoconference with *MSL* team members (Figure 3). Unfortunately, due to logistical difficulties, pre- and post-tests were not administered in 2018. As a follow-up to the five-day programme, the local team returned to INPAR to give a series of presentations over a single week in December 2018.

Outcomes

Pre- and Post-Tests

In the 2015 programme, we evaluated outcomes by administering pre- and post-tests, which focused on measuring competence, autonomy, and relatedness (*Deci & Ryan; Pugh, 2002*). In order to address competence, we measured student knowledge of the scientific method and domain-specific information (e.g. habitability, astrobiology and Mars) before and after participation in the intervention. To address autonomy and relatedness, we measured students’ perceptions of science in their community and their perceptions of using and creating scientific knowledge in their community. The test questions and results are summarised in Tables 2-4⁴. Assessments of these areas for 17 participants in the 2015 programme are summarised in the following sections. We note that 17 respondents is a small sample size and presents challenges for producing statistically significant findings; however, as discussed in the following sections, we have confidence in several results (those with p -values < 0.05 are considered statistically significant).

Competence I: Scientific Method

We summed the number of correct responses on the pre- and post-tests (Table 2), creating a single score which ranged from 0 to 9 with higher scores indicating more correct answers. Results of a paired samples t-test indicated that students had significantly higher scores on the scientific method related questions at post-test ($M=7.06$, $SD=1.06$) compared to pre-test ($(M=4.25$, $SD=1.12)$: $t(15)=-9.63$, p

$< .001$). Students began the study unsure of what data, experimental control, and a hypothesis were, with correct response rates below 24%. Post-test scores showed that students made gains in all areas, although understanding what a hypothesis is proved difficult for students both before and after the programme.

Additionally, we coded student responses to short-answer questions about what the scientific method is, how it could be used to study a local phenomenon, and how one might redesign an experiment to more accurately address a target question. Answers were coded by two researchers for keywords identified by a domain expert with inter-rater agreement above 90%. While students incorporated more keywords in their responses at post compared to pre, the only significant difference emerged for redesign of an experiment. At pre-test, student responses averaged less than one scientific keyword whereas post-test responses averaged more than one keyword.

Competence II: Mars

We summed the number of correct responses to questions about Mars (Table 3), creating a sum score ranging from 0 to 3, with higher scores indicating more correct answers. Overall, students answered significantly more questions correctly at post ($M=1.87$) compared to pre-test ($(M=.68)$: $t(15)=-7.25$, $p < .001$). Most notably, students’ understanding of what a habitat needs to sustain life benefitted from the intervention. This is reinforced by short-answer responses to the question: “What would a human need to survive on Mars?”. While students exhibited knowledge gains about Mars overall, they struggled on questions pertaining to environmental conditions, such as explaining the planet’s red color. Overall, despite difficulty with specific content, students increased their knowledge of Mars and also provided more well-reasoned arguments that life beyond Earth may be possible.

Autonomy and Relatedness

We were also interested in how students perceived the role of science for themselves and their community. We created a measure based on eleven questions that asked students to reflect on their role in conducting science and producing sci-

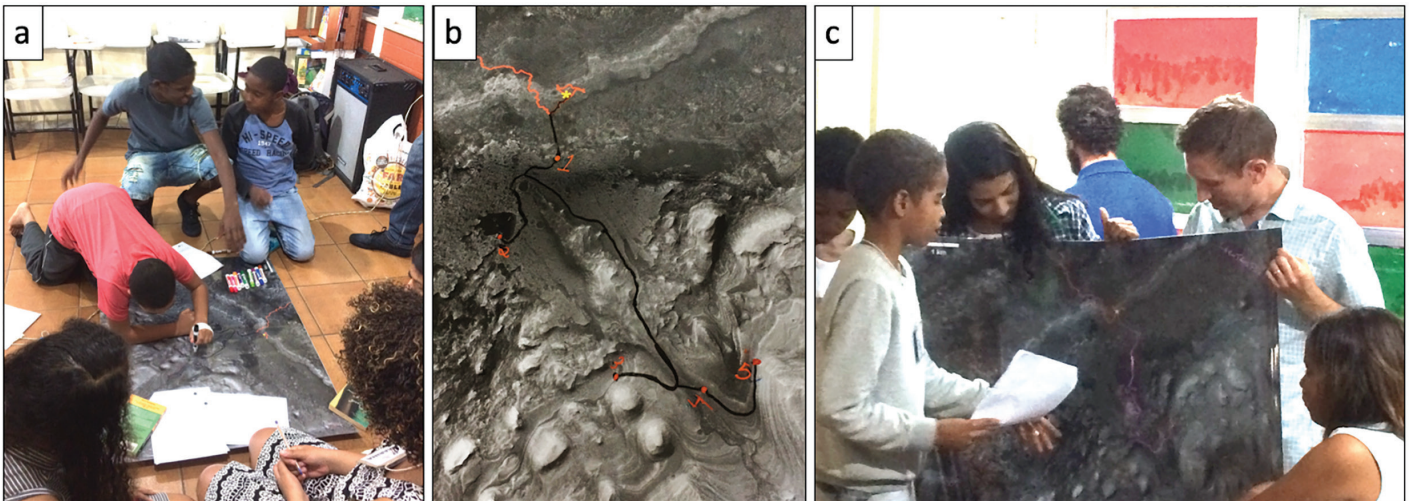

Figure 2. Ad Astra Academy Capstone Project from the 2018 programme: (a) students study a HiRISE image of the MSL Curiosity Rover's landing site in Gale Crater, Mars; (b) traverse locations selected by students on Mt. Sharp in Gale Crater (yellow star indicates the rover's location at the time of the July 2018 programme); (c) students present their future traverse proposals and science rationales to MSL team members via Skype. Credit: Ad Astra Academy

entific knowledge (Table 4). Three of the items were reverse coded so that the direction of all effects could be viewed positively. This resulted in a measure with a minimum of 1 indicating strong disagreement, and 6 indicating strong agreement. Overall, the results indicated a significant increase in students' perceptions of their ability to contribute to scientific knowledge and the ability of science to solve problems from the pre-test ($M=3.68$) to the post-test ($M=5.46$): $t(10)=-3.72$, $p = .004$). Responses for five of the eleven items on the pre-test were below the midpoint of the scale, indicating that students disagreed with statements including, "I am a scientist", "Science can solve any problem" and "In the future, I want to be a scientist", all of which became significantly (p values $< .03$) above the midpoint after completing the programme.

Additionally, an intriguing pattern emerged for the relationship between the role of one's self in science and the role of science in one's community. While students' belief in their ability to carry out their own experiments and to use science to help their community increased, students actually decreased, although not significantly ($p = .18$), in the belief that their community uses science to solve problems. One possible explanation of this decrease is that after gaining first-hand experience of the rigour and limitations of the scientific method, students' confidence in their community's problem-solving science decreased.

However, the validity and implications of this potential link require further targeted study.

Student Experiences

Developing a quantitative understanding of how the intervention may have changed participants' educational paths and career prospects will require several additional years of longitudinal tracking. Nonetheless, individual testimonials and progression through academic milestones suggest that, for a subset of participants, the programme was a transformative event. Several students said that the experience revealed novel ways of viewing and interacting with the natural world. "[The programme] changed my way of thinking," explained one participant, who declared her newfound desire to be an astronomer, "Now, when I walk in the street, I look at the sky." The same student also said that she always liked "the stars and the planets", but she did not know that "something like this could be a profession."

Two of the particularly "at-risk" students noticed a shift in their mindsets toward more active inquiry and enhanced personal agency. "I did not realise that when I'm on a beach, that I can pick things up, collect data and learn more," said one. Another noted that "the project made me think more like this: look at the world around me, and ask several questions."

Another participant is studying for college entrance exams and hopes to pursue a STEM career. She pointed to the Capstone Project as a key motivator, and the overall experience as a memory she would call upon during future struggles. "We took a picture of Mars that no one ever saw or understood," she explained, "and we will be the first people to see it, and I feel a bit special... this project is very important to me; I will never forget this week." This student also benefited from the team's gender diversity: "I was even more motivated because I had a certain fear of being the only woman among the biologists and such, but when I saw other scientists who were women, it encouraged me."

Most striking across the post-programme interviews was the power of new physical experiences to shift students' mindsets. From riding on a boat for the first time, to seeing a jellyfish, observing plankton under a microscope, controlling an underwater robot, and seeing Saturn through a telescope, the density of new experiences created a sense of novelty and excitement that is now associated with curiosity, learning and empowerment.

After 2015, the only INPAR students who pursued any form of higher-education were from the Ad Astra cohort. Of the 20 students who participated in the 2015 programme, two have gone to college, one graduated from a higher-education teaching programme, and another is currently

taking pre-college preparatory courses and exams. While we have insufficient data to attribute these students' decisions directly to their participation in Ad Astra Academy, we plan to follow students from the 2018 programme and future iterations of Ad Astra Academy as well, and will compare to control groups of other INPAR students to assess the long-term impacts of the intervention.

Instructor Best Practices

The strategically designed curricula described above and in Table 1 offer a path for students to gain fluency in performing scientific investigations and learn a great deal about habitability, astrobiology and Mars. However, we believe that confidence-building, attitude-based outcomes are equally important for student success. In this spirit, we developed recommendations for best practices on the key features that make Ad Astra Academy unique throughout both programmes: a passion for learning through experience and exploration, empowerment through inquiry and resilience, and promotion of curiosity and critical thinking. In practice, these goals translated into a few actionable guideposts for all instructors:

1. Consistently remind/encourage students to write or sketch observations in lab notebooks.
2. Encourage students to ask questions at all times, through any mode possible (e.g. verbally or in writing).
3. Lead students along paths of inquiry. If a student's question can be tested, ask guiding questions that direct them to formulate experiments. Prioritise the enactment of these experiments over standard curriculum activities when possible and appropriate.

Convey the range of emotions that come with being a scientist, from the challenges of failed experiments to the joy of solving a hard problem, and contributing new knowledge to the world.

Other Deliverables and Impacts

Spacecraft Images

Based on student requests and scientific reasoning, three high-resolution images

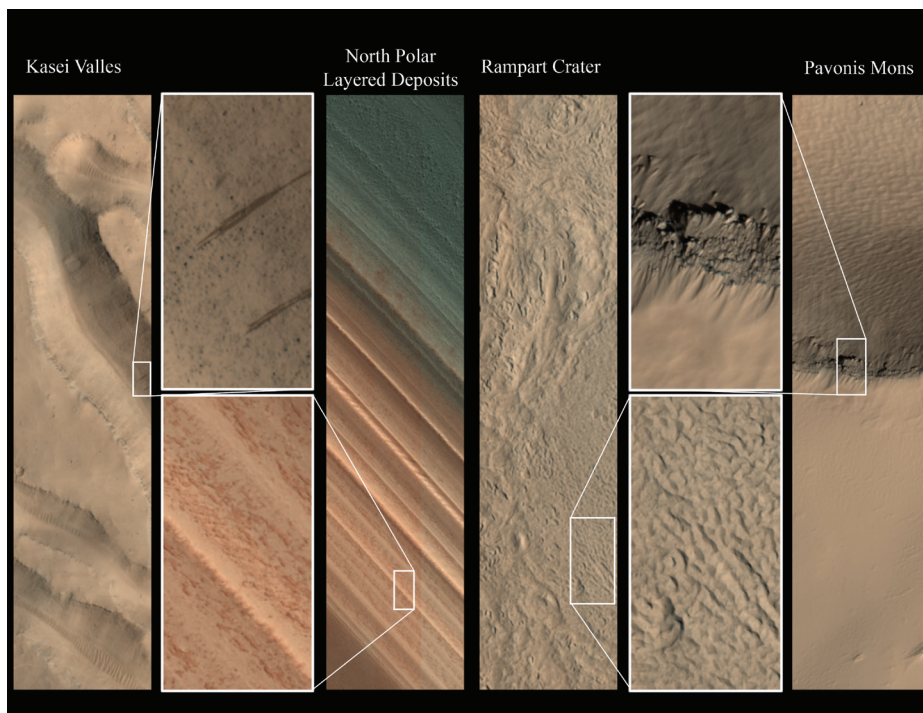

Figure 3. Highlights from the four HiRISE images acquired by the 2015 Ad Astra Academy participants. Inset images show particular areas of interest, including slope streaks at Kasei Valles, dunes of various scales near the north pole, deformed terrain at a putative rampart crater, and a pronounced rock outcrop on Pavonis Mons. Credit: NASA/JPL/University of Arizona

(Figure 3) were acquired by the HiRISE team of: Kasei Valles, the North Polar Layered Deposits, a crater in the mid-latitudes, and the Pavonis Mons volcano⁵. In Kasei Valles, dark slope streaks were observed along channel walls, indicating relatively recent wet or dry flows. At the North Polar Layered Deposits, distinct mixtures of ice and soil form metre- to decametre-scale layers, offering clues to past climatic regimes. The mid-latitude rampart crater was surrounded by broad, rounded shapes, suggesting that the impact may have melted subsurface ice and led to fast-flowing fluidised ejecta. On the northern flank of the Pavonis Mons volcano, three distinct rock outcrops punctuate otherwise flat terrain, whose dunes could help inform atmospheric circulation.

These images would not have been acquired without the partnership between the Ad Astra Academy's student explorers and the HiRISE mission's education and outreach team. We anticipate that the images will be incorporated by the broader research community into existing and future studies, ensuring a substantive student contribution to Mars exploration.

Scholarships

To further the impact of the 2018 programme, we selected two students, aged 16 and 17, for scholarships in partnership with the Museum of Life, in Rio de Janeiro. The students go to the Museum twice a week, participating in their experimental and educational activities. They receive remuneration commensurable with the minimum wage in Brazil. The intent of providing a paid opportunity is to retain them in science and pursuit of college by alleviating the financial pressure that would make them pursue a non-academic minimum wage job with little intellectual stimulation.

Discussion

The exploratory quantitative analysis and anecdotal data presented in preceding sections point to significant positive changes in competence, autonomy and relatedness, as well as more substantial effects on certain students' career objectives and worldviews.

Several challenges—both anticipated and unforeseen—complicated the programme's implementation and may have prevented educational gains from reaching their full potential. As expected given the inclusion of students with poor attendance and behavioural records, disruptive behavior was occasionally distracting. Teaching via translators was a slow process that, at times, limited information transfer and hindered deeper connections between students and international instructors. Teacher training efforts were limited to an information-sharing session and did not allow Ad Astra Academy leaders to observe local teachers' incorporation of key programmatic elements (e.g. active learning, student-directed inquiry, exploration of the natural world) into subsequent classroom activities.

Given our analysis of the pre- and post-tests; interviews with students, teachers, and family members; and Ad Astra Academy team member reflections, future programmes will prioritize several additions and modifications. The telescope night event was an encouraging sign of community interest; enhancing this component by providing students with a platform to share their new knowledge and show the confidence they have attained will build longer-term buy-in from potentially sceptical family members or community leaders. While we hope Ad Astra Academy programmes instil a long-lasting passion for learning in the students themselves, engagement from the students' families is a critical piece of the puzzle. Family member interviews revealed that caregivers almost universally see higher education as a worthy pursuit, but in the face of challenging economic circumstances, income-generating activities take priority. We anticipate that involving caregivers in the student's journey of discovery and curiosity—in addition to the scholarships Ad Astra Academy offers—will lead to a stronger commitment to the long-term benefits of education.

One of the most effective ways to consolidate knowledge gains and develop a deeper understanding of relevant principles is through project-based activities (Kanter, 2010). Our curriculum included several short-term projects, but students would likely benefit from more sustained and self-directed efforts. For example, developing a research agenda to follow up on questions that arose during the week

would nurture a seed of interest. With the tools of the scientific method at their disposal, motivated students would be well positioned to expand their knowledge base.

Other tweaks to the programme will help align our efforts with published best practices. For example, by highlighting the struggles of the international scientists, we can remove the stigma of uncertainty, eliminate the misconception of “innate talent,” and facilitate a growth mindset (Lin-Siegler, 2016). Asking students to reflect on daily activities and the programme's broader lessons in a more private, personal context (e.g. through journaling) will help participants gain ownership of the material and tailor it to their specific circumstances (Zepeda, 2015; Brown, 2015).

Modifications to our team composition and classroom approach would ease the language barrier issues and make the best use of limited time. In both iterations of the Brazil academies, the international team consisted exclusively of scientists; involving trained educators (as has occurred at other Ad Astra Academies around the world) would be helpful in building cohesion and limiting disruptions through classroom management and team-building exercises. Working with translator scientists was an essential yet surprisingly effective part of the process. At their best, the translators who were scientists understood the learning objectives of a given activity and guided groups of students down the path of discovery. This independence saved time by avoiding word-for-word translation and improved knowledge delivery by incorporating culturally-relevant references. To enhance these effects, future programmes will involve local scientists from an earlier stage of curriculum development to ensure all instructors buy in to the programme's underlying objectives and understand the curriculum's progression to attain them.

Local scientists provided a bridge not only in terms of language, but also in their relatability: students could “see themselves” more easily in the local scientists than in the international team members. Given the strong effects of representation in building self-efficacy (Morgenroth, 2015), bolstering this component by involving role models as close to the students' cultural, social, and economic circumstances as possible

is a priority. Nonetheless, we also found that including international scientists provided some unexpected benefits. The range of domain-specific expertise encompassed by the team meant that a broad set of student questions could be answered. Instructors' deep knowledge of experimental design allowed them to quickly arrange demonstrations or experiments to address questions and provide positive reinforcement to curious students. In addition, the “eventised” nature of incorporating international scientists made students feel valued, special, and part of something important. In the 2015 iteration, several participants expressed skepticism that the team would in fact return after the first week of instruction or that *HiRISE* images would be acquired. Demonstrating that scientists from outside the City of God—a traditionally marginalised community—care about students' difficulties and aspirations may provide an emotional boost as important as the intellectual one (Theron, 2012). As one student explained, “When they told me that this project would come to Brazil, I did not really believe it. I do not trust anyone saying they will come here—for me, it is not a possible thing. But when I saw them here, I was like, ‘Ah, it's true!’ I was so surprised.” Another reported, “When I saw the [*HiRISE*] pictures, I felt, ‘Whoa, they said they were going to send them, and they really did bring them back!’ It gave me great joy. We made the photo analysis and have seen some important things.”

In order to scale the core tenets of Ad Astra Academy's pedagogical approach—experiential, inquiry-based learning through the lens of exploration—disseminating these principles through local teachers is essential. After all, teachers have more sustained contact with students and their families and are better positioned to tailor instructional approaches to an individual pupil's interests and life circumstances. A more extensive teacher training programme that allows time for practise and feedback for both the international Ad Astra Academy team and local teachers would be a productive next step.

Many of our future course corrections seek to build a culture of knowledge and exploration around Ad Astra Academy students. Our initial evidence suggests that, for many participants, the spark of inspiration caught hold, but it needs fuel—in

the form of family support, longer-term projects that reinforce key principles, and classroom environments that promote student inquiry—to continue burning. While developing a full infrastructure of support is beyond the scope of our programme, the relatively straightforward modifications highlighted above will help capitalise on the knowledge, attitude and behavior gains students attain from the punctuated Ad Astra Academy experience.

Conclusions

Ad Astra Academy programmes in Brazil have sought to instil a passion for knowledge and exploration in under-resourced communities among students with limited educational and economic opportunities. Through brief, interactive interventions designed to empower students to contribute to the leading edge of space exploration, many students reported transformational impacts. Analysis of pre- and post-tests indicated that participants expressed a markedly enhanced ability and desire to engage in scientific research following the programme. Substantial methodological challenges for the study remain, including the collection of long-term data to evaluate the programme's impact on career success. Nonetheless, we are encouraged by the initial results presented here, which support our hypothesis that brief, impactful interventions can play a positive role in a student's educational trajectory through enhanced autonomy and self-efficacy.

References

- 'Mapa do encarceramento: os jovens do Brasil / Secretaria-Geral da Presidência da República e Secretaria Nacional de Juventude', Brasília: Presidência da República, 2015, https://nacoesunidas.org/wp-content/uploads/2018/01/Mapa_do_Encarceramento_-_Os_jovens_do_brasil.pdf
- Brown, E.R., J.L. Smith, D.B. Thoman, J.M. Allen, and G. Muragishi, 'From bench to bedside: A communal utility value intervention to enhance students' biomedical science motivation,' *Journal of Educational Psychology*, vol. 107, no. 4, 2015, p. 1116
- Deci, E., and R. Ryan, 'The "What" and "Why" of Goal Pursuits: Human Needs and the Self-Determination of Behavior', *Psychological Inquiry*, vol. 11, 2000, p. 227-268, doi: 10.1207/S15327965PLI1104_01
- Dweck, C.S., 'Mindset: the New Psychology of Success (updated edition)', Ballantine Books: New York City, 2016
- Fernandez-Rio, J., N. Sanz, J. Fernandez-Cando and L. Santos, 'Impact of a sustained Cooperative Learning intervention on student motivation', *Physical Education and Sport Pedagogy*, vol. 22, no. 1, 2015, p. 89-105, doi: 10.1080/17408989.2015.1123238
- Heddy, B. C., and G. M. Sinatra, 'Transforming Misconceptions: Using Transformative Experience to Promote Positive Affect and Conceptual Change in Students Learning About Biological Evolution', *Science Education*, vol. 97, no. 5, 2013, p. 723-744, doi:10.1002/sce.21072
- Instituto Brasileiro de Geografia e Estatística (IBGE), 'Síntese de Indicadores Sociais – 2015', uma análise das condições de vida da população brasileira [online], Rio de Janeiro, 2015, <http://biblioteca.ibge.gov.br/visualizacao/livros/liv95011.pdf>
- Kanter, D.E., 'Doing the Project and Learning the Content: Designing Project-Based Science Curricula for Meaningful Understanding,' *Science Education*, vol. 94, no. 3, 2010, p. 525–551
- Linnenbrink-Garcia, L., E.A. Patall, and R. Pekrun, 'Adaptive Motivation and Emotion in Education', *Policy Insights from the Behavioral and Brain Sciences*, vol. 3, no. 2, 2016, p. 228-236, doi:10.1177/2372732216644450
- Lin-Siegler, X., J.N. Ahn, J. Chen, F.F.A. Fang, and M. Luna-Lucero, 'Even Einstein struggled: Effects of learning about great scientists' struggles on high school students' motivation to learn science,' *Journal of Educational Psychology*, vol. 108, no. 3, 2016, p. 314
- Morgenroth, T., M.K. Ryan, and K. Peters, 'The Motivational Theory of Role Modeling: How Role Models Influence Role Aspirants' Goals,' *Review of General Psychology*, vol. 19 no. 4, 2015, p. 465-83
- Psacharopoulos, G., and H.A. Patrinos, 'Returns to Investment in Education: A Further Update', *Education Economics*, vol.12, no.2, 2004, p. 111-134
- Pugh, K., 'Teaching for Transformative Experiences in Science: An Investigation of the Effectiveness of Two Instructional Elements', *Teachers College Record*, vol. 104, no. 6, 2002, p. 1101-37
- Theron, L., P. Engelbrecht, and M. Ungar, 'Caring Teachers: Teacher–Youth Transactions to Promote Resilience,' *The Social Ecology of Resilience: A Handbook of Theory and Practice*, NY: Springer New York, New York, 2012, p. 265-280
- Valdesolo, P., A. Shtulman, and A.S. Baron, 'Science is awe-some: The emotional antecedents of science learning', *Emotion Review*, 2016
- Walton, G.M., 'The New Science of Wise Psychological Interventions.' *Current Directions in Psychological Science*, vol. 23, no. 1, 2014, p. 73-82
- 'World health statistics 2018: monitoring health for the SDGs, sustainable development goals,' World Health Organization, [online] Geneva, 2018, Licence: CC BY-NC-SA 3.0 IGO <https://apps.who.int/iris/bitstream/handle/10665/272596/9789241565585-eng.pdf?ua=1>
- Wigfield, A., and J.S. Eccles, 'Expectancy–value theory of achievement motivation', *Contemporary Educational Psychology*, no. 25, vol. 1, 2000, p. 68–81, doi:10.1006/ceps.1999.1015
- Yeager, D.S. and G.M. Walton, 'Social-psychological interventions in education: They're not magic,' *Review of Educational Research*, vol. 81, 2011, p. 267–301
- Zepeda, C.D., J.E. Richey, P. Ronevich, and T.J. Nokes-Malach, 'Direct instruction of metacognition benefits adolescent science learning, transfer, and motivation: An in vivo study', *Journal of Educational Psychology*, vol. 107, no. 4, 2015, p. 954-970

Notes

¹ There are many NGOs acting in the *favelas*, though most are related to sports or arts. Ad Astra Academy is one of the first science-focused programmes operating in the *favelas*.

² In the 2015 report from the Instituto Brasileiro de Geografia e Estatística in the references document shows that of those who completed secondary education, 55% were men and 67% were women in the whole country. When broken down by race, there was a 12% gap in favor of women widens to 19% when only people of darker skin tone are considered. This government report that this may be due to societal gender norms that direct boys into the workforce at an early age, making them manage both work and study. This is potentially the reason for the disparity in the school-directed selections.

³ Academic engagement was based on school attendance, performance, and motivation.

⁴ Tables 1, 2, 3 and 4 are available online at the CAPjournal website: www.capjournal.org

⁵ The images have the following IDs: Kasei Valles (image ID ESP_043797_2070), the North Polar Layered Deposits (image ID ESP_042748_2650), a crater in the mid-latitudes (image ID ESP_042536_2170), and the Pavonis Mons volcano (image ID ESP_052317_1830).

Acknowledgements

We dedicate this manuscript to Loloano Claudionor da Silva, a Brazilian scientist and indispensable Ad Astra Academy local team leader, who passed away unexpectedly in January 2019. We will miss him greatly as we continue the work that he cared so deeply about, as will the many students who have been inspired by his kindness, humor and passion for learning. Ad Astra Academy thanks the following sources of funding that have made the Brazil programmes possible: the International Astronomical Union, Rolex, and the National Geographic Society. We thank Hank Leukart, Alejandra Frias, and Julia DeMarines for their contributions as Ad Astra team members. We thank Liliane Mynssen and the entire INPAR staff including the students who participated in the

Ad Astra Academies, GalileoMobile, Rio de Janeiro's Museum of Astronomy, Rio de Janeiro's City Planetarium, the NGO Parceiros da Educação, Patricia Spinelli, Sandra Benitez Herrera, João Paulo Nogueira Cavalcante, Raquel Boesso Silva, Leandro Guedes, Wailã de Souza Cruz, Flavia Lima, Alexandre Cherman, Daniel Mello, and Silvia Lorenz. Finally, we also thank the *MRO HiRISE* team and *MSL* team members Vandí Verma, Matt Heverley, Katie Stack Morgan and Abigail Fraeman.

Biographies

Wladimir Lyra is an Assistant Professor of Astronomy at New Mexico State University and Brazil Site Director of the Ad Astra Academy.

Melissa Rice is an Associate Professor of Planetary Science at Western Washington University. She is a science team member of the NASA Mars Science Laboratory and Mars-2020 Rover missions.

Dhyan Adler-Belendez received his Master's degree from the Harvard Graduate School of Education. His work focuses on improving mathematics and science education.

Neil Jacobson is a PhD candidate at the University of Southern California's Rossier School of Education. His work investigates the conceptual change process as it applies to scientific, social, historical, and political knowledge.

Ana Pantelic is a social entrepreneur and international development professional with a decade of experience working at the intersection of systems change, social innovation, and economic opportunity.

Karolina Garcia is a PhD candidate in astronomy at the University of Florida, studying galaxy clusters and supernovae.

Leonardo Sattler Cassara is an astrophysicist currently working as a Research Assistant at the Federal University of Rio de Janeiro.

Carolyn Crow is a Planetary Scientist and Cosmochemistry in the Department of Geosciences at the University of Colorado Boulder and the Program Director for the Ad Astra Academy.

Paul Hayne is an assistant professor of astrophysical and planetary sciences at the University of Colorado Boulder, and is Science Director for the Ad Astra Academy.

Jeffrey Marlow is an Assistant Professor of Biology at Boston University and the Executive Director of the Ad Astra Academy.

CAP journal

Communicating Astronomy with the Public

Dear Readers,

Please contribute to improving CAP journal, by filling in our short questionnaire at:

<https://www.capjournal.org/survey.php>

We welcome your feedback!



Astronomy as a Tool for Peace and Diplomacy: Experiences from the Columba-Hypatia Project

Francesca Fragkoudi
on behalf of GalileoMobile and AHDR

Max Planck Institute for Astrophysics
ffrag@mpa-garching.mpg.de

Keywords

Astronomy for Peace

Science, and astronomy in particular, can be used for the benefit of society and for achieving the United Nations Sustainable Development Goals (SDGs). In this article we present the Columba-Hypatia project, a flagship Astronomy-for-Peace project, whose goal is to use the vision of the cosmos that astronomy imparts us with, to promote peace and diplomacy in post-conflict regions (SDG 16: Peace Justice and Strong Institutions) while also empowering women to be leaders in STEM and in the peace-building process (SDG 5: Gender Equality). The project is a joint endeavour by GalileoMobile and the Association for Historical Dialogue and Research (AHDR) that takes place on the divided island of Cyprus. Columba-Hypatia brings together children and educators from the separated communities of Cyprus to inspire them to be curious about science, while using astronomy as a tool for promoting meaningful communication, a feeling of global citizenship and a Culture of Peace and Non-violence. We describe the successes and challenges faced by the project in order to serve as an example of implementing Astronomy-for-Peace projects in other post-conflict regions.

Introduction

On Cyprus, Greek-Cypriots (GCs) and Turkish-Cypriots (TCs), the two main ethnic communities of the island, have been living separated from one another for over 45 years in a post-conflict environment¹. Between the TCs in the north-east of the island and GCs in the south-west is an area known as the “United Nations Buffer Zone in Cyprus” or “Green Line,” which is controlled by the United Nations Peacekeeping Force in Cyprus, and was established in 1964. Crossing the buffer zone, an area which ranges from a few metres to a few kilometres wide, was largely not possible until 2003 when checkpoint crossings were opened and allowed GCs and TCs access to both sides of the island. However, while the checkpoints have been open for almost 17 years, interaction and cooperation between the two communities is still rare and the political situation is at a general stalemate.

Achieving peace and strong institutions is one of the United Nations Sustainable Development Goals (SDGs). As evidenced by numerous projects carried out under the auspices of the International Astronomical Union Office of Astronomy for Development (IAU OAD)², astronomy, and science overall, can be of benefit to meeting these goals and advancing the wellbeing of society. Astronomy in particular is a well-

suited tool for bringing people together in post-conflict regions: it imparts us with a much broader perspective, allowing us to see beyond national and ethnic boundaries. Discovering our cosmic origins and our place in the universe naturally inspires a feeling of global citizenship, increasing our “in-group”³ (*Tajfel, 1971*) and empathy towards others (*Fukushima & Venugopal, 2015*). Furthermore, it is a topic which fascinates and excites, and as such is easily introduced in classrooms and extracurricular activities and helps attract both children and educators who might otherwise not be interested in engaging in “reconciliation” activities.

The aim of this grass roots project is to inspire children and the general public to be more curious about science and the universe and through this bring together children and adults from the two communities to learn about each other in order to break down prejudices and misconceptions. The initiative promotes meaningful communication and a Culture of Peace and Non-Violence in order to further the SDG 16: Peace, Justice and Strong Institutions and SDG 5: Gender Equality.

The Columba-Hypatia project is implemented by two organisations, GalileoMobile⁴ and Association for Historical Dialogue and Research (AHDR)⁵. GalileoMobile is an itinerant, non-profit out-

reach project that shares astronomy with students and teachers in schools and communities worldwide. The team is comprised of a group of volunteer astronomers, educators and science communicators from around the world. Since its inception in 2008, GalileoMobile has reached 1400 teachers and 16 000 students, donated more than 100 telescopes and organised public events for more than 2500 people in 14 countries⁶. GalileoMobile teaches astronomy across the world in a spirit of inclusion, sustainability and cultural exchange to create a feeling of unity under the same sky.

AHDR is an intercommunal organisation (i.e. it is composed of both GCs and TCs) based in Cyprus whose mission is to contribute to the advancement of historical understanding amongst the public, and more specifically amongst children, youth and educators, by providing access to learning opportunities for individuals of every ability and ethnic, religious, cultural, and social background, based on respect for diversity and dialogue of ideas.

The project began in 2017, first with the implementation of a one-day pilot run. The project subsequently obtained funding by the IAU OAD in 2017 to expand operations, and was followed by an inspired-by project in 2018. Additional educational materials were donated by the European

Southern Observatory's former education and Public Outreach Department (ESO ePOD)⁸ and Universe Awareness (UNAWE)⁹, and telescopes were donated by Meade Instruments Corporation¹⁰. In 2019 the project was again funded by the IAU, in the context of the IAU centenary celebrations, as a flagship project and example of best practices for using astronomy as a tool for peace and diplomacy. The project received additional funding from the Max Planck Institute for Astrophysics¹¹ in Garching, Germany.

Description of the Columba-Hypatia Project

The main phase of the project began in 2017 and ran throughout the entire year. The target groups of the project were children in primary schools, teenagers, the general public and educators from both the GC and TC communities.

The project focused on visits by science communicators from GalileoMobile and the local communities to public mono-communal primary schools and bi-communal activity days, where children ages 9-12 from the aforementioned schools came together to meet each other and participate in astronomy activities, which were modified from the *Handbook of Activities* from GalileoMobile¹². These are described in the following subsections. The bi-communal activities were carried out at the Home for Cooperation, a unique community centre located in the buffer zone in the heart of Nicosia, the divided capital of Cyprus. Jointly run by GCs and TCs, it is the embodiment of intercommunal cooperation, contributing to the collective efforts of creating a civil society through peacebuilding and intercultural dialogue. The Home for Cooperation essentially aims to act as a bridge-builder between the separated communities, memories and visions. It provides working spaces and opportunities for individuals and non-governmental organisations to design and implement innovative peacebuilding projects.

For the general public we held free astronomy outreach events in the afternoons and evenings in locations accessible to GCs and TCs. We also carried out astronomy activities at a bi-communal summer camp for youths. However, the main emphasis and focus of the project was on the

Audience	Number of participants in 2017
School children	~190
Teachers	~20
Youth	~100
General public	~150
Documentary viewers	~5700

Table 1. Number of participants in 2017 activity

mono-communal school visits and bi-communal activities, since these could reach the most diverse audience and have the largest impact.

The numbers of participants are listed in Table 1.

Mono-communal School Visits

During the mono-communal visits we focused on introducing the children to the project as well as basic astronomy concepts. The astronomy activities were chosen to give the children an idea of the place of the Earth in the context of modern astronomy and to introduce them to the vast scales and sizes of the universe, e.g. by comparing the sizes of stars and

planets through the activity "The Earth as a Peppercorn". We also carried out activities with the UNAWE Earth Ball to show how the Earth looks from space and introduce the concept of human-made borders. At the end of the day we carried out solar observations with the donated Coronado telescopes (Figure 1).

At the end of each school visit, we also prepared the children for the bi-communal meetings. This was done by discussing expectations and allowing the children to ask questions about the meeting and entering the buffer zone, since it is a demilitarised region which the children often perceive with apprehension.



Figure 1. Solar observations during a mono-communal training. Credit: Francesca Fragkoudi/Columba-Hypatia

Bi-communal Activity Days

During each of the five bi-communal days, one GC and one TC school were paired-up and children from the two communities came together in the buffer zone, specifically at the Home for Cooperation, to participate in astronomy activities and get to know each other in order to break down barriers and preconceptions.

Before starting the main activities, we carried out icebreaker activities which gave the children the opportunity to relax and introduce themselves to each other (Figure 2).

The main two activities carried out were selected such that they would give the children the opportunity to interact with their peers from the other community while also inspiring a sense of global citizenship. The selected activities were “Building a Cyprus Golden Record” and “Building Constellations in 3D”. For the former, the children were split into mixed groups of six to eight and they discussed what they would send to an alien civilisation as a representation of the whole island of Cyprus (Figure 3). Each group was responsible for a given topic that would be included on the Golden Record (e.g. food, music), much like the scientific groups that selected the content of the Golden Record on the Voyager spacecraft. The small group sizes allowed for easy interaction between the children. However, since the children did not speak the same language (Greek and Turkish), translators were necessary in each group to help the children discuss with each other.

The second activity, “Building Constellations in 3D” (Figure 4), was selected to encourage the children to think about how our point of view affects how we view a certain object or problem. Constellations appear the way they do because of our position in the galaxy—if we viewed them from a different position in the galaxy, they would appear different. Our point of view is therefore a crucial aspect to how we perceive a constellation. This type of experiment was chosen to help the children develop the ability to see multiple perspectives, which is invaluable given the complex historical situation in Cyprus and the differing interpretations of history that perpetuate the divide on the island.



Figure 2. Children from the GC and TC communities in Cyprus carrying out one of the ice-breaker activities during a bi-communal meeting. Credit: Fabio del Sordo/Columba-Hypatia

Events for the General Public

In 2017, two speaking events for the general public were done by astrophysicists from Cyprus and abroad on current topics in astrophysics, including gravitational waves, galaxy evolution and astronomy for development. Special emphasis was placed on having a representative number of female astronomers presenting their work in order to promote positive scientist role models, which is particularly necessary in Cyprus where gender inequality is prevalent in all aspects of society and especially in the sciences (European Commission, 2012). This action was done in consideration of SDG 5: Gender Equality. These talks were then followed by live music and telescope observations of the night sky. The events were held in the old town of Nicosia, south of the Green Line, as well as in the buffer zone. Both areas were easily accessible from both sides of the buffer zone.

As part of the Columba-Hypatia project, trainers from the project took part in the Cyprus Friendship Program summer camp, to carry out global-citizenship-related activities (Figure 5). During this summer camp, teenagers from the GC and TC communities come together for a week in the mountains of Cyprus to learn about each other, breaking down barriers and

stereotypes. Our participation included an astronomy intervention with talks by astrophysicists on modern topics of astronomy, question-and-answer sessions and telescope observations.

Project Reception

The project was anecdotally well received both by the teachers as well as the participating children. The participants showed enthusiasm and genuine curiosity about members of the other community, and reported feelings of improved understanding and empathy of each other after the bi-communal visits¹⁴.

As one child said, “There are too many things that we don’t know about each other; that’s why we shouldn’t see things only from our own point of view. When I first met them [referring to children from the other community] I felt left out. But after we got to know each other, everything became better.”

In order to measure this effect of the increase of the childrens’ in-group and empathy, in future instalments of the project we plan to evaluate the “Pale Blue Dot effect” in which “...knowing one’s place in the Universe alters perception and induces

more empathy towards fellow humans” (*Fukushima & Venugopal, 2015*). This will be achieved through questionnaires and interviews before and after the activities, developed in collaboration with psychologists and experts on Peace Education implementations.

Resources and Materials Developed

As part of the Columba-Hypatia project we translated selected activities from the GalileoMobile handbook into Greek¹⁵ and Turkish¹⁶ and adapted the activities where necessary. These activities are freely available online through the GalileoMobile website⁴.

We developed a 10-minute documentary¹⁴ summarising the goals and activities of the project, which shows the reception the project received from the children through short interviews. The film aims to serve also as inspiration for similar projects to be carried out.

As part of the 2019 implementation of the project we will develop an Astronomy-for-Peace handbook, which we hope will be used for other Astronomy-for-Peace activities in other regions around the world. We plan to make this handbook freely available online (see “The Global Component of the 2019 Implementation”).

Challenges in Project Implementation

The most important challenges we faced for implementing the project were due to the local context and political situation in Cyprus. Since there is very little official political contact between the two communities, and each side does not officially recognise the other, it was challenging to obtain permits from the Ministries of Education to visit the schools as well as permits to bring the children to the United Nations controlled buffer zone. To obtain access to the schools we also needed the permission of the headmaster or headmistress, who therefore had to be sympathetic to bi-communal initiatives. To bring the children to the buffer zone we had to obtain written consent forms from the parents, which were distributed and collected

by the teachers and schools. In some cases, parents did not allow their children to participate in the bi-communal events. However, it is worth noting that in some cases after the mono-communal school visits, the children were so enthusiastic about the astronomy aspect of the project that they were able to convince their parents to sign the consent form for the bi-communal visits. Since the bi-commu-

nal meetings had to be carried out outside of official school hours (due to lack of permits from the Ministries of Education) we had to rely heavily on the teachers committing their free time to bringing the children to the buffer zone to participate. Therefore, having contact with committed and motivated teachers and headmasters or headmistresses was crucial for the success of Columba-Hypatia.



Figure 3. Top: Talking about the Voyager space probes and the Golden Record. Bottom: The Cyprus Golden Record, constructed by children participating in one of the bi-communal activity days. Credit: Columba-Hypatia



Figure 4a & 4b. Students build the Columba Constellation. Credit: Columba-Hypatia

The other main difficulty faced during the implementation of the project was the reliance on volunteers for carrying out the bi-communal activity days. As stated earlier in “Description of the Columba-Hypatia Project”, we needed a large number of volunteers present during these activities. This was mainly due to the fact that we split the children into eight to ten small groups, and meant that we often needed the presence of at least 16-20 volunteers who would act as translators between Greek and English and Turkish and English¹⁷. It was therefore operationally challenging to ensure that that amount of people could be present for each of the bi-communal events on a purely volunteer basis.

The Global Component of the 2019 Implementation

During 2019 the project added an additional global component in its implementation. To this aim, one of the deliverables of the project is to develop an Astronomy-for-Peace handbook which will give some basic guidelines for how to implement Astronomy-for-Peace projects in differ-

ent contexts, the lessons learnt, and what was important for the Cypriot context. Every local context is different, therefore a set of rules that works globally is hard to develop. However, there are certain educational astronomy activities that are particularly suited to the promotion of global citizenship and peace, and there are certain important lessons that were learnt during the project implementation in the last three years. The handbook will be made publicly available on our website¹⁸ and through the IAU OAD.

The other aspect which contributes to the global component of the Columba-Hypatia project is the beginning of a network of Astronomy-for-Peace projects. This began during the International Institute for Peace Education (IIPE) conference in Cyprus in July 2019¹⁹. During this conference, projects in Zambia and Colombia were selected for their potential in implementing astronomy-for-peace programmes and invited to learn more at the IIPE conference. The goal will be for these projects to develop astronomy for peace programmes adapted to their local context with support from the Columba-

Hypatia team. Additionally, during the IIPE, contacts were made with a number of peace educators from around the globe, and the first seeds were planted for further collaborations three other countries with post-conflict regions. Other groups or individuals interested in such activities are encouraged to contact the OAD and the Columba-Hypatia team for support. The ultimate goal of this network is for it to grow and support Astronomy-for-Peace projects in various post-conflict contexts or divided communities around the world.

Summary

In this article we outlined outcomes and lessons learnt from the Columba-Hypatia: Astronomy for Peace project. The project uses astronomy as a tool for peace and diplomacy in the post-conflict region of Cyprus, thus serving as a flagship project in which astronomy is used for development, and in particular towards SDG 16: Peace, Justice and Strong Institutions and SDG 5: Gender Equality, by using

astronomy to break down barriers and stereotypes.

Notes

- ¹ More information is available on the United Nations Peacekeeping Force in Cyprus website: <https://unficyp.unmissions.org/about>
- ² International Astronomical Union Office of Astronomy for Development (IAU OAD) website: <http://www.astro4dev.org/>
- ³ An "in-group" is a social group one identifies with. Examples of in-groups include families, sport teams, gender identities or religions.
- ⁴ GalileoMobile website: <http://www.galileo-mobile.org/>
- ⁵ Association for Historical Dialogue and Research website: <https://www.ahdr.info/>
- ⁶ GalileoMobile programme reports are available on their websites : <http://www.galileo-mobile.org/galileomobile-resources/galileomobile-reports>
- ⁷ This included astronomy activities for children and youths carried out in the Buffer Zone. These were open to any participants who signed up beforehand.
- ⁸ European Southern Observatory: <https://www.eso.org/public/>
- ⁹ Universe Awareness (UNAWA): <https://www.unawe.org/>
- ¹⁰ Meade Instrument Corporation: <https://www.meade.com/>
- ¹¹ Max Planck Institute for Astrophysics: <https://www.mpa-garching.mpg.de/>
- ¹² GalileoMobile handbook on the GalileoMobile website: <http://www.galileo-mobile.org/galileomobile-resources/galileomobile-handbooks>
- ¹³ Cyprus Friendship Program: <https://friendships4peace.org/cyprus-friendship-program/>
- ¹⁴ Columba-Hypatia: Astronomy for Peace documentary: <https://www.youtube.com/watch?v=wWhBZcYIAcc>
- ¹⁵ Greek translations of selected activities from the GalileoMobile handbook: <https://drive.google.com/file/d/1yb46jbdYdh7-KMQ792Fn2tOd3o-8bFez/view>
- ¹⁶ Turkish translations of selected activities from the GalileoMobile handbook: https://drive.google.com/file/d/1EMBXJfxaldJ2cdY28yHWjjcySPJbelF_/view
- ¹⁷ There are not many Greek-Turkish translators who were able to work with children and on a limited budget, so translations needed to go through English during the activities.

¹⁸ Columba-Hypatia: Astronomy for Peace website: <https://www.columbahypatia-project.org/>

¹⁹ International Institute for Peace Education: <https://www.i-i-p-e.org/>

References

- Tajfel, H., et. al., "Social categorization and intergroup behaviour", *European Journal of Social Psychology*, vol. 2, no. 1, 1971, p. 149–178.
- Fukushima, K. and R. Venugopal, 'First Step to Understand Intergroup Bias and Cohesion from the One World Experiment: A Pilot Project to Evaluate the Effect of the 'Pale Blue Dot' Hypothesis', *CAPJournal*, no. 23, 2015, p. 26
- European Commission, 'She Figures 2012: Gender in Research and Innovation', European Commission, 2012, http://ec.europa.eu/research/science-society/document_library/pdf_06/she-figures-2012_en.pdf

Acknowledgements

The Columba-Hypatia project received funding from the International Astronomical Union's Office of Astronomy for Development, the Max Planck Institute for Astrophysics and the United Nations Peacekeeping Force in Cyprus. The project received donations in the form of telescopes and other educational materials from Meade Instruments, the European Southern Observatory, and Universe Awareness. The project team would like to thank the many volunteers without whom the original installations of the project would have not been possible. The project team would like to dedicate this article to the memory of our teammate Natalie Christopher, a shining star who left us too soon.

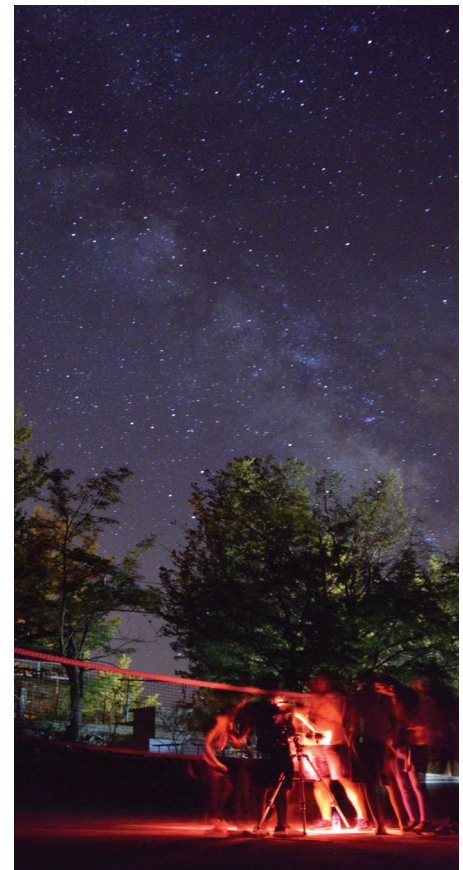

Figure 5. Columba-Hypatia activities at the Cyprus Friendship Program camp. Credit: A. Papadopoulos

Biography

Francesca Fragkoudi, originally from the island of Cyprus, is an astrophysicist and science communicator based at the Max Planck Institute for Astrophysics. Apart from her research on the evolution of galaxies such as our own Milky Way, she is the founder of the Columba-Hypatia: Astronomy for Peace project, which uses astronomy as a tool to promote a culture of peace and non-violence in her divided home country.

Astrotourism in The Mara

Dennis Kulvinder

Kabarak University / Development of Africa with Radio Astronomy (DARA)
gkulvinder@gmail.com

Brian Bichang'a

University of Cape Town / DARA
brianbichanga@gmail.com

Maurice Wafula

Technical University of Kenya / DARA
morwanjala@gmail.com

Eric Meli

University of Nairobi / DARA
eric.meli@students.uonbi.ac.ke

Bonface Osoro

University of Strathclyde / DARA
bonfaceosoro@gmail.com

Simon Ndiritu

Max Planck Institute of Astrophysics / DARA
swndiritu@gmail.com

Paul Akumu

University of Mauritius / DARA
palakumu@gmail.com

Alex Orieko

University of Nairobi / DARA
jontejkuat@gmail.com

Kioko Mutisya

Paramount Chief Kinyanjui Technical Training Institute / DARA
kiokmuts@gmail.com

Carringtone Kiyanjui

University of Manchester / DARA
kinyanjuicarrington@gmail.com

Samyukta Manikumar

Development of Africa with Radio Astronomy (DARA)
samyukta.mn@gmail.com

Paul Baki

Department of Physics, Technical University of Kenya / DARA
paulbaki@gmail.com

Keywords

Astrotourism, socio-economic development

Astrotourism offers the night sky as a product and service to be sold to tourists. We present the implementation of astrotourism in the Maasai Mara National Reserve, a renowned game park on the border of Kenya and Tanzania. By the formation of partnerships with private members of the hospitality industry, we have been able to take the first steps in the establishment of a thriving astrotourism industry in Kenya. We have leased a telescope to two lodges and conducted basic astronomy training to the staff of those lodges in the reserve known as The Mara. This training is meant to augment the traditional wildlife tourism of the area. Our team is currently assessing the viability of the product as a business model, and we are in talks with representatives from the University of Dar es Salaam on the possibility of introducing a similar product in Tanzania.

Introduction

The Kenyan tourism industry is one of the largest sources of revenue for the country (Sindiga, 2018). Kenya's ideal equatorial location, low light-pollution in rural areas and relatively dry climate make it a strong candidate for astrotourism. Kenya also has the highest unemployment rate in East Africa, with 9.2% of Kenyans being unemployed. The youth (15-24) unemployment rate is a staggering 17.6% (UNDP, 2019). With more young people graduating each year and the job pool only becoming more competitive, it is important to develop new industries that can provide young Kenyans with stable, secure jobs. This motivated the formation of the astrotourism project Sayari ("Planet" in Swahili).

Sayari is meant to ignite and give weight to the astrotourism industry in Kenya. Astrotourism has been explored as an economic possibility in South Africa (Jacobs, 2019) and Namibia (Gairiseb, 2019). By

introducing astrotourism into the national park with the most tourist traffic (which are more frequented by tourists than nearby villages and town), Sayari aims to generate

local community development, employment opportunities and revenue.



Figure 1. The Sayari team who are part of the DARA-Kenya Cohort 3 students attend the DARA networking meeting in Muldersdrift, South Africa. Credit: Sayari

Astrotourism is a service industry which relies on two forms of knowledge. The first is local knowledge of the night sky otherwise known as ethnoastronomy (Holbrook, Medupe, & Urama, 2008). The second is an appreciation for the night sky in the modern scientific paradigm. Thus, it can be argued that the night sky is not the product being sold, but knowledge. It was this that informed us of the need to begin Sayari by conducting training in the local lodges.

Training

The Sayari team trained guides from two lodges based in the Maasai Mara National Reserve in Narok County, Kenya. Two four-day long trainings were conducted concurrently at Governors' Camp Mara and Ashnil Mara Camp in the Maasai Mara Game Reserve. Training took place between the 27 November and 1 December 2018. A team of eight students travelled to the Maasai Mara Nature Reserve. Four trainers placed at each camp trained the lodge guides. The lodge guides were permanent staff in the lodges. They were then trained in basic optical astronomy and modern scientific knowledge of celestial bodies to enable them to educate the visiting tourists. Each lodge was also provided with a telescope. The trained guides are expected to also conduct outreach sessions within the local community to educate community members about conservation and light pollution (Holker, 2010a).

At both camps, we were able to train ten guides. Some of the guides who attended the training had some prior experience with astronomy and physics which made con-

tent dissemination easy. The guides were enthusiastic and motivated to learn during training. They confessed that they did not consider dark skies as an important concern of conservation. During the training we emphasised the value of dark sky conversation (Walker, 2010), pointing out the importance of dark skies to human and animal sleep patterns (Holker, 2010b), which the guides reported to have found illuminating. The Maasai Mara is in an excellent position to promote dark sky awareness, as it is one of Kenya's main tourist attractions, and we found that it already has sustainable ecological practices in place.

Outcomes

Increased Understanding of Science

Almost all of our trainees had very limited prior knowledge of theoretical and practical astronomy. After the training they could confidently differentiate between properties of various celestial bodies, use mobile phone applications to track celestial objects, and even identify specific objects in the night sky.

Increased Revenue from Tourism

The short term increase in revenue from the lodges will be tracked for a span of one year from their implementation of astronomy in their tourism packages. The long term increase might be harder to monitor, but we expect it to be correlated to the increase in the number of trained guides (trained directly by our team or through a guiding school if we can get our training content certified as a short course). One

camp has begun a pilot test of the programme and the team will work with them as they finalise the implementation.

Challenges & Recommendations

Complexity of Content

Astronomy is a vast field of knowledge. It was challenging to find the right balance in terms of how much detail to go into and what to omit. We also did not know the extent of our trainees' science background. They absorbed most of the material well, but there were instances where they were encountering challenging concepts for the first time. This can be remedied by formalising the course content and teaching it in a tourism guiding school. This can then be taught over an extended period of time.

Monitoring

Most of the students engaged in the preparation and implementation of the project have since left for further studies out of the country. We are currently in search of a contact in Kenya to help us monitor the impact of the project in the long term.

Sourcing of Local Ethnoastronomy Stories

From our interactions with the tourists, we have realised that a large part of their experience is immersion in local culture. This includes an interest in local ethnoastronomy. The Plain Nilotes residents in the area have a rich ethnoastronomy tradition which will be explored in later work. Implementations of a similar pro-



Figure 2a & 2b. The Sayari team prepares to travel to Maasai Mara, a game park in southwestern Kenya. Credit: Sayari



Figure 3. The Sayari team during a public outreach mission in Kirisia Boys High School in the town of Maralal, Kenya. Credit: Sayari team

ject should strive to add a local flavour to it by researching local myths and legends about the stars, planets and constellations.

Conclusion

We have explored the possibility of introducing astrotourism in two lodges in the Mara. While judgement of the sustainability of the project cannot yet be made, there are positive signs of astrotourism developing into a product in the Mara. In the long run, we hope to apply for a dark sky status (Welch & Dick, 2012) in the game reserves, especially for those located in the Southern Rift Valley (Maasai Mara) and towards the equator (Laikipia, Samburu, Maralal, and Sibiloi National Parks). Having dark sky preserves across Kenya is expected to increase the revenue from tourists by the diversification of products sold. We are currently in talks with astronomy academics in Tanzania who are interested in running a similar project in Tanzania.

Acknowledgments

The Sayari Project thanks Development in Africa with Radio Astronomy (DARA), for financing the project; the Office of Astronomy for Development (OAD), for facilitating the smooth running of the project; the Technical University of Kenya, for providing support, in cash and kind, to the project; and Governors' Camp and Ashnil

Mara Camp, for providing support and staff for the training.

References

- Gairiseb, A., 'In Integrated space for african society', Springer, Namibia, 2019, p. 201-215
- Holbrook, J., R.T. Medupe, and J.O. Urama, 'African cultural astronomy: Current archaeoastronomy and ethnoastronomy research in africa', Springer Science & Business Media, 2008
- Holker, F. et al., 'Light pollution as a biodiversity threat,' Trends in ecology & evolution, 2010a, vol. 25, no. 12, p. 681-682
- Holker, F. et al., 'The dark side of light: a trans-disciplinary research agenda for light pollution policy.' Ecology and Society, 2010b, vol. 15, no. 4
- Jacobs, L. et. al., 'Rough road to the stars: A route development framework for astro tourism in the karoo arid region.', 2019
- Sindiga, I., 'Tourism and african development: Change and challenge of tourism in kenya', Routledge, 2018
- United Nations Development Programme (UNDP), 'Human development report 2019', UNDP, 2019
- Walker, C. E. et. al., 'Promoting dark skies awareness programs beyond the international year of astronomy 2009.' Bulletin of the American Astronomical Society, vol. 42, 2010, p. 409
- Welch, D. and R. Dick, 'Dark-sky parks', Environmental Impact of Light Pollution and its Abatement, vol. 30, 2012

Biography

Dennis Kulvinder is a telecommunications engineer with interest in radio astronomy. He holds a bachelor's degree in telecommunications from Kabarak University. He is the current Sayari Coordinator.

Brian Bichang'a is a student at the University of Cape Town pursuing a research master's degree in astronomy. He is a beneficiary of the South African Research Chairs Initiative (SARChI) South African Astronomy Observatory (SAAO)/National Research Fund (NRF) scholarship.

Maurice Wafula works at KOKO Networks as a calibration technician, a venture-backed technology company operating in East Africa and India. Maurice is a trained DARA student.

Eric Meli holds a bachelor's degree in astronomy and astrophysics from the University of Nairobi. He is also a graduate of DARA's basic training programme.

Bonface Osoro is a master's student in the University of Strathclyde doing satellite applications with data science. Previously, he studied geospatial engineering at the Technical University of Kenya.

Simon Ndiritu

Paul Akumu is currently working on an MPhil/PhD project, setting up an array of parabolic antennas for the Mauritius Radio Telescope (MRT) site for radio astronomy experiments at the University of Mauritius.

Alex Orieko holds a bachelor's degree in astronomy and astrophysics from the University of Nairobi. He is currently working for Airtel Communications Limited.

Kioko Mutisya holds a bachelor's degree in electrical and electronic engineering from the Jomo Kenyatta University of Agriculture and Technology.

Carringtone Kiyanjui is a master's student at the University of Manchester studying science policy and communication under DARA-Big Data. He holds a Masters of Science in physics (theoretical) from the University of Nairobi.

Samyukta Manikumar has a Bachelor of Science (Honors) in Applied Mathematics, with a focus on cosmology, from the University of Cape Town. She has also been trained in radio astronomy through the DARA programme.

Professor Paul Baki is the Chairman of the Department of Physics at the Technical University of Kenya. He is also the national point of contact for DARA in Kenya. He was the principal investigator of the Sayari project.



SUSTAINABLE LOCAL SOCIO-ECONOMIC DEVELOPMENT

THROUGH ASTRONOMY

Astronomy for:

**ECONOMIC DEVELOPMENT • JOBS CREATION
SKILLS DEVELOPMENT • LOCAL INNOVATION
EDUCATION**

A flagship program of the International Astronomical Union's
Office of Astronomy for Development



www.bit.ly/2NEZd7c



Dark Sky Sim: An Open-Design Dark Sky Simulator

Andreas Papalambrou

International Dark-Sky Association, Greek Chapter
 coordinator@darksky.gr

Nadia Bali

International Dark-Sky Association, Greek Chapter
 coordinator@darksky.gr

Keywords

Resources, tools, DIY, dark skies

This article describes the key steps on how to construct the Dark Sky Simulator, the outcome of the Dark Sky Sim project. The Dark Sky Simulator is a “physical simulator” to demonstrate the effects of light pollution on the starry sky and the concept of proper lighting. The simulator consists of an LED sky model simulating the starry sky and LED model streetlighting. The simulator creates for users a first-hand experience of light pollution caused by various light fixtures. The simulator was successfully completed, and information on how to construct a simulator with simple tools and inexpensive components are made available online for free. Building the simulator is a very exciting STEM project involving hands-on construction and programming skills in addition to learning astronomy concepts, making it a useful resource for both educational and outreach communities. The project was funded by the International Astronomical Union Office of Astronomy for Development (IAU OAD).

Introduction

STEM projects form an important part of the educational process in science. Dark Sky Sim took the opportunity to combine astronomy and environmental concerns about light pollution into a STEM project that includes learning about astronomy, construction and programming. The environmental issue of light pollution that lies in the heart of this project will be crucially important in the years to come, and through the dark sky simulator students and citizens can learn about the issue while at the same time learn programming and astronomy.

Most people have never seen a truly dark sky, which is undeniably the best way and most immediate way to perceive the issue of light pollution. Photographs and videos are useful in demonstrating what a dark sky looks like, but as they don't involve a deep engagement with a dark sky, they aren't as effective. To solve this problem of experience, the project team members concluded that a physical simulator with interactive controls would be the best way to demonstrate the issue of light pollution without a dark sky. This simulator was designed to be educational through both the construction skills one practices and the information one learns, during which one gains first-hand experience with the constellations and how they are affected by light pollution.

Light Pollution

Dark skies are becoming increasingly rare for citizens living in urban areas. According to *The New World Atlas of Artificial Night Sky Brightness* (Falchi, 2016), about 80% of people worldwide and 99% of Americans and Europeans cannot see the Milky Way from their homes. Light pollution, however, is not simply about night sky heritage and inability to see the stars. We now know that it is a complex environmental issue affecting plants, animals and us human beings, disrupting our sleep cycles and contributing to serious health conditions (Chepesiuk, 2009).

Light pollution is unique as an environmental issue in that it can theoretically disappear instantly if we simply turn off the lights, unlike other important issues such as global warming or microplastic pollution which we can't simply make disappear even if we take all appropriate measures today. This doesn't mean that light pollution is easy to solve, due in part to the years of societal perception of public lighting and, of course, that we don't want to turn off the lights completely¹.

Overview of the Construction

The dark sky simulator consists of a wooden box, an interchangeable sky background, a scale model setting and electrical components as shown in Figure 1.

These create a diorama of a desired scene, such as a park at night.

Building the simulator is accomplished in three stages: the construction stage, the electrical wiring stage and the programming stage. A full explanation of the complete construction, including building materials and code, is freely accessible on the Dark Skies Sim website².

Construction

Assembling the Simulator Box

The simulator box is the frame for the sky and houses the electrical components. Users construct the box and scale-model base using plywood, glue or screws, and metal furniture corners (a complete list of materials is in Box 1). The base is roughly 60 cm x 50 cm, half of which is covered by a box that is roughly 60cm x 25 cm x 45 cm. Metal furniture corners at the front of the box hold the interchangeable plexiglass “sky” that is added later.

The scale-model scene of the simulator may be glued to base in front of the box. A park, for example, could be created with green velvet paper for the ground with model figurines, benches and trees. Light fixtures can be created by inserting LEDs through a short black straw and be attached to the base.



Figure 1. Overview of the simulator. Image credit: Dark Sky Sim project

Making a Sky Background

A sky background is created with a 60 cm x 45 cm sheet of plexiglass. Making it requires some astronomy knowledge or the use of a planetarium software. It is advised that the sky background depicts an area of the sky that is of significant interest, such as the winter constellations around Orion, the circumpolar constellations or the Summer Triangle asterism. The depicted part of the sky can be of constellations visible from a specific location, especially if the simulator is being used with a local scope. Depending on the project, two alternate night sky scenarios (e.g. winter and summer sky) may be helpful in fully showing what is lost through light pollution.

To transfer the constellation onto the plexiglass, a screenshot from the planetarium software can be printed on transparent paper of appropriate size (such as two A4 pages). The constellation pattern can then be transferred into the plexiglass by drilling holes into the plexiglass using an elec-

tric drill at slow speed. The diameter of the drill tip should be such that the LEDs can be wedged in the holes.

For simulating the stars, LEDs can correspond to the stars they represent. White HI LEDs can be used for the most relatively prominent stars, while white LO LEDs can be used for less-prominent stars. Orange LEDs can represent stars that are particularly orange or red in appearance like Betelgeuse and Antares.

Electronics

A breadboard for electronics is used to hold the wiring and lights for the back of the simulator box (Figure 2). The LEDs are controlled through an Arduino*3 board, a commonly used programmable circuit board that is easy to use for beginning programmers. The code is processed through the board and controls the brightness, and sometimes colour, of the LEDs of the "stars" and "streetlights".

Box 1. Components

Main board

1 x Arduino Uno or Mega board
 Arduino shields
 1 x Arduino power motor shield (e.g. Velleman KA03)

Power supplies

1 x DC 4.5V 1A Power supply
 1 x USB 5V 1A Power supply
 LED's
 25x white high brightness LED's
 25x white low brightness LED's
 5x orange LED's
 5x blue LED's

Switches and cables

1x 3-way switch
 1x up/down switch
 1x large breadboard
 50x long jump wires M/JF 40cm
 50 x short jump wires M/M 10cm
 10x very short jump wires for short circuit
 1x 5-meter silicon cable 1.5mm2

Scale Models

10 x 1:100 scale model figures
 5 x 1:100 scale model benches
 5 x 1:100 scale model bikers
 5 x 1:100 scale model trees
 1x Green velvet sheet
 10x white LED's
 10x orange LED's
 5x Black plastic straws
 Glue

Simulator Box

2x 45x25x1 cm plywood sheets
 1x 60x25x1 cm plywood sheet
 1x 60x25x0.5 cm plywood sheet
 1x 60x45x1 cm plywood sheet
 1x 60x50x1.5 cm plywood sheet
 2x plexiglass sheets 60x45x0.3 cm
 1x drawer handle
 20x 5cm furniture metal corners
 1x dark blue spray paint
 2x (any dark color of choice) spray paint
 20x Wood screws
 Wood glue
 Tools
 Electric drill
 Screwdriver
 Pliers
 Soldering iron
 Permanent marker
 Scissors

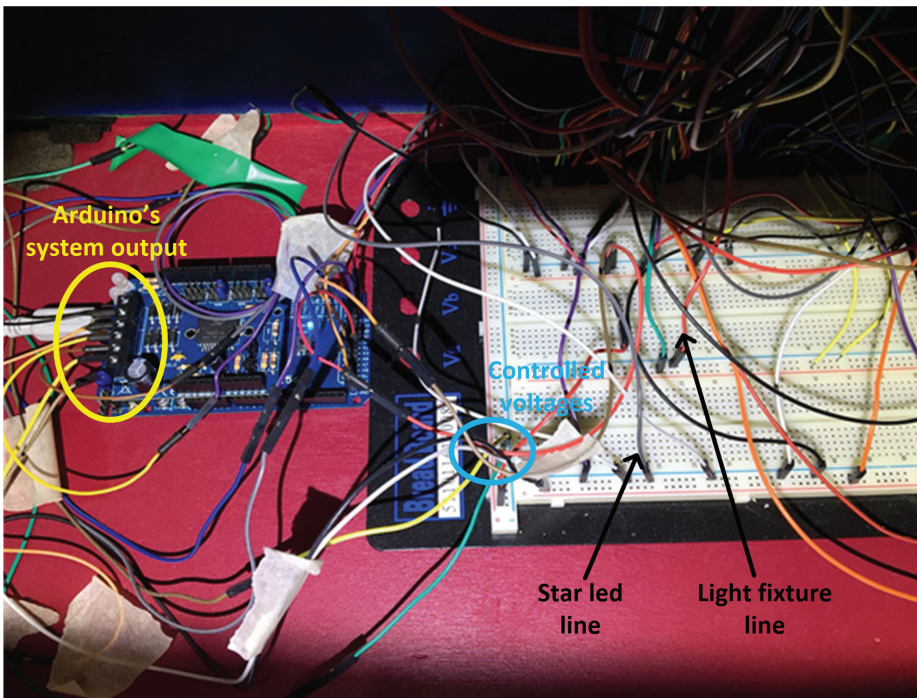

Figure 2. Wiring of the simulator. Credit: Dark Sky Sim project

Programming

The user of the simulator can adjust the brightness of the LEDs through the pre-designed code.

The light pollution depends on two factors: The intensity of the light fixtures in the scene and the colour-type of the LEDs that are placed in the scene. The lights can be controlled to three different levels—zero, warm light (3000 Kelvin) and cold light (6500 Kelvin, which is often used to simulate daylight). Cold light is known to cause more light pollution and make stars seem fainter. This and other topics associated with light pollution can be explored through the control of the lighting by the user. The code and more technical details about the programming are available on the project website².



Figure 3. Logo of the Dark Sky Sim Project. Credit: Dark Sky Sim project

Conclusion

The Dark Sky Simulator is a resource that can be used for both learning and light pollution advocacy. The simulator has been demonstrated at the 2019 Annual General Meeting of the International Dark-Sky Association (IDA) in Tucson, US and was well received as a STEM project for schools as well as dark-sky advocacy. A logo of the simulator was designed (Figure 3) in order to better promote it. The simulator has also been demonstrated for schoolchildren at the 2018 Patras Science Festival in Patras, Greece and for the members of the Greek IDA chapter and Astronomical Society of Patras Orion.

Informal feedback gathered at events and demonstrations regarding its usefulness as a light pollution simulator device has been positive, however many formal educators felt it was too complicated for construction for classroom environment due to their lack of training in programming and electronics. Some people also noted that the simulator is quite bulky. In order to address these concerns, a smaller, more portable version of the simulator is being designed and an automatic programming script will be designed for people unfamiliar with programming.

The open nature of the project means that anyone can modify and improve the design, and the authors will be glad to receive user modifications and improvements.

References

Chepesiuk, R., 'Missing the Dark: Health Effect of Light Pollution', Environmental Health Perspectives [online], vol. 117, no. 1, 2009, p. A20-A27, <https://www.ncbi.nlm.nih.gov/pmc/articles/PMC2627884/>

Falchi, F. et al, 'The new world atlas of artificial night sky brightness', Science Advances, vol. 2, no. 6, 10 June 2016, e1600377

Notes

- ¹ More practically, light pollution can also be mitigated with aiming lights downward, only using light that is needed, using warm white bulbs and making good use of our natural low-light eye adaption.
- ² The Dark Sky Sim project website: <https://darkskysim.com/>
- ³ 'Introduction' on the Arduino website: <https://www.arduino.cc/en/guide/introduction>

Acknowledgements

The authors would like to thank the International Astronomical Union and especially the Office of Astronomy for Development for financing and supporting this project.

Biography

Andreas Papalambrou is the coordinator of the Greek Chapter of the International Dark-Sky Association and holds a degree in electrical engineering and a master's degree in Lighting Design.

Dr Nadia Bali is a member of the Greek Chapter of the International Dark-Sky Association and holds a bachelor's degree in physics and master's degree and PhD in Chemical Engineering.

Astronomy in Indigenous Communities

Ismael Moumen

Université Laval/CFHT
ismael@cfht.hawaii.edu

Laurie Rousseau-Nepton

Canada-France-Hawaii Telescope Corp.
r-nepton@cfht.hawaii.edu

Nicolas Cowan

McGill University
nicolas.cowan@mcgill.ca

Samar Safi-Harb

University of Manitoba
samar.safi-harb@umanitoba.ca

Julie Bolduc-Duval

Discover the Universe
julie@discovertheuniverse.ca

Mary Beth Laychak

Canada-France-Hawaii Telescope
laychak@cfht.hawaii.edu

Keywords

Indigenous People, Diversity, Inclusion,
Astronomy for Development

Astronomy in Indigenous Communities (AIC), previously named Astronomy for Canadian Indigenous People (ACIP), aims to use astronomy as a development tool for Indigenous People in First Nations communities of Canada. AIC's main objective is to collaborate with First Nations communities to provide students with opportunities to explore the night sky and the universe from both Indigenous and Western perspectives. Via presentations, field trips, activities, and personal interactions with professional astronomers, we aim to stimulate dialogue between the students, their broader community, and astronomers to understand and learn from each other's perspective of the universe. During the pilot project in 2019, the AIC team worked with two First Nations communities in the Province of Quebec: The Hurons-Wendat near Quebec City and the Abenaki near the city of Trois-Rivieres. We reached young students, members of the communities, as well as teachers. The project had four components: (i) Visiting schools in the First Nations communities to reach young Indigenous students, (ii) facilitating a visit for those students to the Mont-Mégantic Observatory, (iii) organising an outreach event for participating communities and (iv) organising a webinar on astronomy for teachers. The pilot project was funded by the International Astronomical Union Office of Astronomy for Development (IAU OAD), the Canadian Astronomical Society (CASCA) and the Centre for Research in Astrophysics of Quebec (CRAQ). In 2020 version of AIC, we are targeting three communities near the city of Montreal.

Introduction

For more than 150 years, Indigenous people in Canada have endured hard conditions, such as, higher rates of unemployment, poor education, bad housing and poor job prospects. Despite government efforts to improve this situation, the limited success rates of government programmes, such as the continued low levels of education and high level of school drop out (*Kelly-Scott & Smith, 2015*), indicate that these efforts have not been sufficient. Astronomy in Indigenous Communities (AIC), previously named Astronomy for Canadian Indigenous People (ACIP)¹, follows a society-society approach² to help improve the situation of Indigenous people in Canada by using astronomy as a tool for the development of young Indigenous People. We hope that this non-governmental approach will reduce educational and occupational inequality in Canadian society by offering the youth a message of perseverance, motivation and hope for

a brighter future. In this article we present the pilot project held in 2019, the current project in 2020, and our future objectives.

Astronomy for Canadian Indigenous People (ACIP): The Pilot Project

ACIP began in 2019 as a pilot project. During the first version of the programme, we worked with two First Nations communities in the Province of Quebec—the Hurons-Wendat near Quebec City and the Abenaki near the city of Trois-Rivieres (Figure 1)—because of their proximity to the Mont-Mégantic Observatory, one of the oldest telescopes in Canada. Our target audience was students aged 8-14 years old, as well as their teachers and broader community. The ACIP pilot project had four components:

1. Visiting young Indigenous students in Wendake;

2. Interact with Indigenous communities in Quebec City and Trois-Rivieres;
3. Bring a group of students to visit the Mont-Mégantic Observatory during the Mont-Mégantic Popular Astronomy Festival;
4. Connect teachers from Indigenous schools to the Discover the Universe programme, which provides online teacher training in astronomy.

Visiting Indigenous Communities

In the first part of ACIP pilot project, we made one visit each to the Wahta' School located in the community of Wendake, the Native Friendship Centre of Quebec in Quebec City, and the Native Friendship Centre of Trois-Rivieres in the city of Trois-Rivieres. The 70 Indigenous youth who participated were excited by the presentations and activities prepared by Dr. Laurie Rousseau-Nepton, resident astronomer at the Canada-France-Hawaii Telescope (CFHT) and the first indigenous woman in

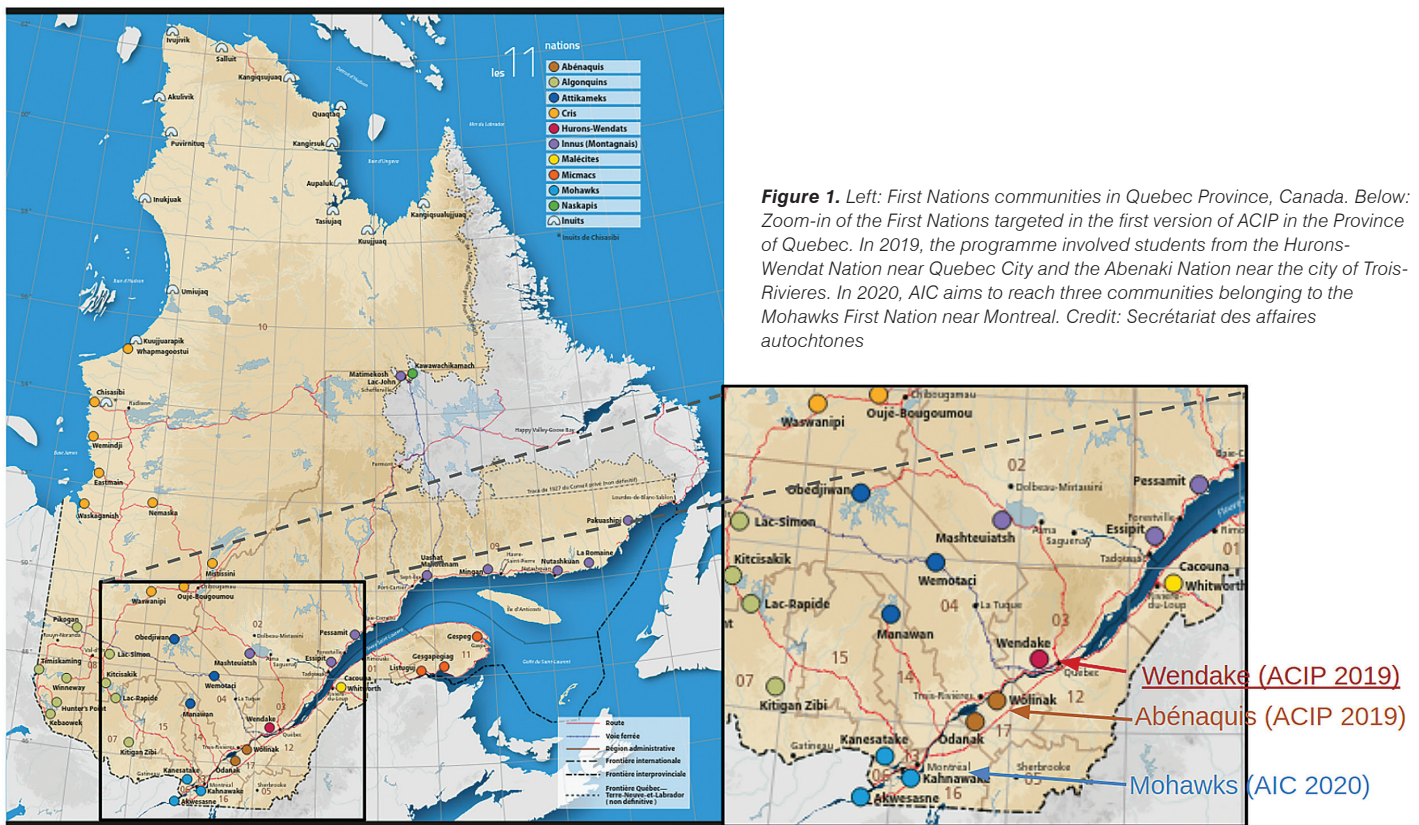

Figure 1. Left: First Nations communities in Quebec Province, Canada. Below: Zoom-in of the First Nations targeted in the first version of ACIP in the Province of Quebec. In 2019, the programme involved students from the Hurons-Wendat Nation near Quebec City and the Abenaki Nation near the city of Trois-Rivières. In 2020, AIC aims to reach three communities belonging to the Mohawks First Nation near Montreal. Credit: Secrétariat des affaires autochtones

Canada to obtain a PhD in astrophysics, and Mary Beth Laychak, CFHT Outreach Manager. During these two-hour long visits, we shared our perspective on astronomy while listening to insights of the Indigenous culture and facilitated hands on activities to engage students in the joy of “doing science” (Figure 2, Figure 3). These activities were chosen to exchange knowledge on Western and Indigenous astronomy and make connections between the two cultures. The students were also provided take away materials (stickers, calendars, edible space molecules, etc...) to connect them to their experience.

Attending the Mont-Mégantic Popular Astronomy Festival

In the second part of this project, 19 students and five adults from the two centres attended the Mont-Mégantic Popular Astronomy Festival³ organised by the ASTROLab at Mont-Mégantic Park, a dark-sky reserve (Figure 4). During the afternoon and evening, they attended presentations and screenings organised by the ASTROLab. The students asked a lot of questions to the presenters and animators, showing much curiosity. When the

animators asked for volunteers, the students didn’t hesitate to involve themselves in the activity (Figure 5). Overnight, they went up to the Mont-Mégantic Observatory and attended activities at the summit with the astronomers of the observatory and the animators of the park. These activities included observations with the 1.6m telescope of the observatory, visits to the different parts of the observatory, and presentations about research done with the telescope. Students stayed a long time to do observation with the 1.6m telescope (Figure 6) and asked a lot of interesting questions about planets, stars, and the universe.

Following both the community visits and field trips, a few students clearly manifested their interest in becoming an astronomer or astronaut, such as two students who are now pursuing astronomy projects for a science competition.

Webinar for Teaching Astronomy

In collaboration with Julie Bolduc-Duval, director of Discover the Universe (À la découverte de l’univers)⁴, a special webinar was expected to be offered to teachers

involved in the ACIP programme. This webinar was scheduled for September 2019 but was postponed until 2020. This webinar will allow teachers to learn about activities and resources for teaching astronomy in their communities. The goal of this component is to provide tools for teachers to teach astronomy, where they can learn new activities, ask questions to experts, and get new resources helpful to teach astronomy to young Indigenous students. It is tailored to our society-society-based approach and includes a component of First Nation astronomical knowledge.

Astronomy in Indigenous Communities (AIC)

Based on the success of our ACIP pilot project in 2019, we decided to follow the same society-society approach to reach Indigenous people in other communities in Canada and use astronomy as a tool for the development of Indigenous youth.

For the now AIC project, we will target three new communities. All are part of the Mohawks First Nation in the Province of Quebec near Montreal. This geography

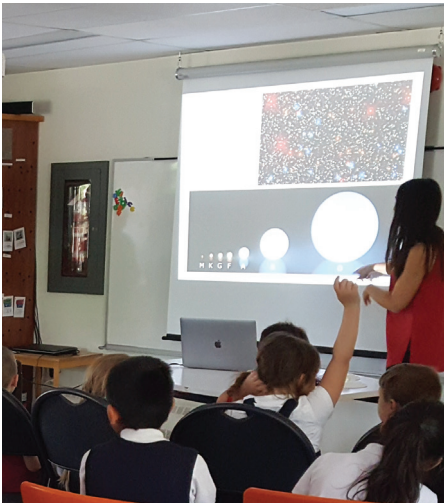

Figure 2. Indigenous astronomer Dr. Laurie Rousseau-Nepton presents to the students in the Wahta' School near Quebec City. Credit: ACIP 2019



Figure 3a & 3b. Dr. Laurie Rousseau-Nepton and Mary Beth Laychack, both of the Canada-France-Hawaii Telescope, present to students at the Native Friendship Centre of Trois-Rivieres. Credit: ACIP 2019



leverages proximity to the Mont-Mégantic Observatory. Again, our participants will be students 8-14 years old, and we expect a higher number of participants than in 2019. In 2020, the AIC project will have the same structure but with an additional component: Visiting the Rio Tinto Alcan Planetarium in Montreal.

Visits to the Schools

Like in 2019, we have contacted Canadian and other non-First Nations Indigenous astronomers to give presentations on

astronomy and Indigenous cultural astronomy. They will be supported by outreach staff from a number of Canadian institutions, many new to AIC. The astronomers will talk about their own experience to inspire the young participants and motivate them to pursue their studies to have better jobs and careers. Training will be provided to the speakers so they are better prepared to engage with the students' knowledge of First Nation astronomy rather than focusing exclusively on Western-based knowledge.

Trip to the Rio Tinto Alcan Planetarium

In 2020, student groups will also visit the Rio Tinto Alcan Planetarium in Montreal. This new activity was added to our programme thanks to the collaboration with the director of the planetarium and their vision for including Indigenous heritage in the planetarium. The staff will prepare a visit by offering different activities such as a showing of a film about the aurora borealis, *Aurorae*, and other films, presented with live commentary, like the American Museum of Natural History's *Dark Universe* and National Geographic's *Asteroid: Extreme Mission*. The final programme will be determined later in 2020.

Trip to the Mont-Mégantic Popular Astronomy Festival

The same groups will attend the Mont-Mégantic Popular Astronomy Festival in order to do a programme similar to the one in 2019. This trip programme includes a visit to the Mont-Mégantic Park and attending the presentations and activities organised by the ASTROLab during the afternoon and evening, and a visit to the 1.6m telescope at the summit during the night.

Teacher Training

Discover the Universe online training will be offered again to the teachers of the participating students.



Figure 4a & 4b. Young Indigenous students play inside the ASTROLab of the Mont-Mégantic Park. Credit: ACIP 2019



Figure 5. A young Indigenous student (and maybe a future astronaut) shows a certificate for exploring the Solar System, which was won by participating in the ASTROLab activities during the Mont-Mégantic Popular Astronomy Festival. Credit: ACIP 2019

Conclusion

We believe that while astronomy can be helpful in advancing knowledge, astronomers could also be very helpful to the development of human society. AIC, previously named ACIP, aims to play this role and use astronomy as a tool of development for Indigenous people in First Nations communities.

We hope that our society-to-society approach can provide another way to alleviate one of the major challenges of high school-drop-out rates and lower levels of education in Indigenous communities. By creating connections with the communities, delivering positive messages of motivation and perseverance, and breaking walls between the youth and their ambitions, AIC helps each child go beyond their dreams.

In 2021⁵, we will target other remote Indigenous communities in the province of Quebec and propagate the AIC project to other provinces in Canada. We plan to collaborate with more players inside and outside the First Nations communities. Many Indigenous people in the world face the same issues and we hope that the lessons learnt from the AIC project can be helpful for similar projects dedicated to Indigenous communities internationally.

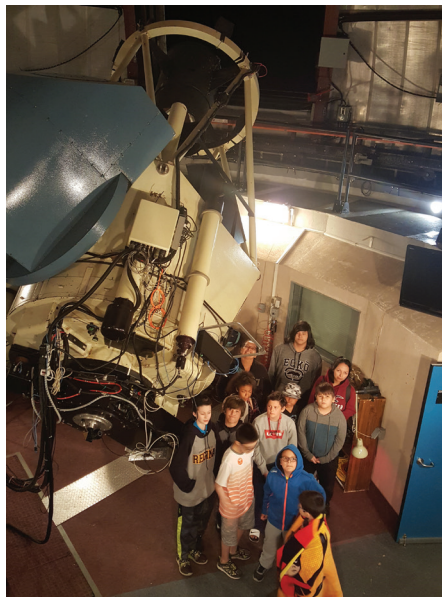

Figure 6. A group of students with the 1.6m telescope of the Mont-Mégantic Observatory. Credit: ACIP 2019

References

Kelly-Scott, K. and K. Smith, 'Aboriginal peoples: Fact sheet for Canada', Statistics Canada [online], no. 890656-X20150000, 30 November 2015, <https://www150.statcan.gc.ca/n1/pub/89-656-x/89-656-x2015001-eng.htm>.

Notes

- ¹ ACIP 2019 website: <http://www.ismael.free.fr/acip2019/>
- ² The "society-to-society" approach is an initiative coming from a member of the society to support other members in the society in order to improve the other member's social, economical and financial situation.
- ³ Mont-Mégantic Popular Astronomy Festival website: <https://www.astrolab.qc.ca/en/activity/festival/>
- ⁴ Discover the Universe (À la découverte de l'univers) website: <https://www.discovertheuniverse.ca/>
- ⁵ If you want to help, collaborate, or if you have ideas to improve this project, please contact the AIC team.

Acknowledgements

This project became a reality thanks to the different kind of support from our partners: International Astronomical Union Office of Astronomy for Development (IAU OAD); Canadian Astronomical Society (CASCA); Centre for Research in Astrophysics of Quebec (CRAQ); Canada-France-Hawaii Telescope (CFHT); Mont-Mégantic Observatory (OMM); McGill University; The ASTROLab Centre of Mont-Mégantic National Park; Discovery the Universe/À la découverte de l'Univers; Native Friendship Centre of Quebec; Native Friendship Centre of Trois-Rivières; and The Wahta' School (École Wahta') in Quebec City.

Biography

Ismael Mouden is a PhD student under a co-supervision of Laval University and CFHT. He is a leader of the Astronomy in Indigenous Communities (AIC) project and is involved in many socio-scientific projects aiming to democratise astronomy and use it as a tool of societal development.

Laurie Rousseau-Nepton is a member of the Pekuakamiinuash First Nations community and the first woman from a First Nations community in Canada to attain a PhD in Astronomy. She is a resident astronomer at the Canada-France-Hawaii Telescope on the Big Island of Hawaii.

Nicolas Cowan is an associate professor at McGill University. He studies the climates of exoplanets, advocates to protect the climate of our planet, and strives to create an equitable and welcoming environment in the physical sciences.

Samar Safi-Harb is Professor of Physics & Astronomy and Lead for Equity, Diversity and Community for the Faculty of Science at the University of Manitoba. Her research explores the aftermath of supernova explosions of stars and high-energy astrophysical phenomena that fascinate the public and the next generation of scientists.

Julie Bolduc-Duval is the director of the educational program Discover the Universe where she helps K-12 teachers by providing astronomy workshops and resources. Involved in many science education initiatives, she is also passionate about making the world a better place through astronomy and education.

Mary Beth Laychak is the Outreach Manager of the Canada-France-Hawaii Telescope.

How Astronomers Perceive the Societal Impact of Research: An Exploratory Study

Michelle Willebrands

Leiden University
willebrands@strw.leidenuniv.nl

Pedro Russo

Leiden University
russo@strw.leidenuniv.nl

Keywords

Societal impact, societal relevance, societal return

We present an exploratory study of the perception of professional astronomers about the societal impact of astronomy. Ten semi-structured interviews with astronomers from a range of career and cultural backgrounds have been conducted to gain in-depth insight into their opinion about societal impact and their approach in realising it. The results show that the interviewees are aware of the diversity of impacts that astronomical research has. However, they are mostly active in outreach and only a few activities are incorporated into their jobs to achieve an impact on development. There is little contact with stakeholders in industry, policy or other fields, like development. Besides, a structured approach in their personal outreach is lacking, and assessment is only done informally. Despite the limited sample size of this study, the results indicate that a further change is necessary to engage professional astronomers with topics of development and societal impact to create action on the level of individual researchers.

Introduction

In most research institutes, there are three main aims: research, teaching and public engagement. However, the latter is often neglected, although in the past years there has been a growing emphasis on the societal impact of science. The societal impact of science can be understood as science that includes societal benefit and affects societal challenges (Bornmann, 2013). It entails social, cultural, environmental, and economic returns and engages societal actors, such as policymakers, industry, and end users.

Astronomy impacts societies in different ways by producing certified knowledge; training skilled workers; driving innovation by pushing technical limits; contributing to collective goods, like prestige of a country and environmental awareness; and by inspiring people (Davoust, 1995). Serendipity is extremely important in astronomical discoveries (Fabian, 2010), and societal applications of science are often arrived at non-linearly (Schneider, 2007). More spin-offs might even come from fundamental than applied research (Llewellyn Smith, 2008). Rosenberg et al. (2014) gathered a wealth of examples of applications originating in astronomy, from X-ray luggage belts to hospital cleanrooms. However, they conclude that maybe the most important consequence of astronomy is that it

highlights our place in the universe and promotes global citizenship. Astronomy can also contribute to socioeconomic development (McBride, 2018).

Background

The process of creating societal impact can be captured in a four-step process (Meijer, 2012). Firstly, the societal objectives are defined, and subsequently the stakeholders and activities to connect with them. Next, the impact must be measured with indicators, and finally, the results are reflected by scoring each indicator to adjust the objectives if necessary.

Outreach efforts of physicists and biologists mostly concern presentations for children and activities for a general audience, like public lectures (Ecklund, 2012). Perceived impediments to outreach activities include the “Sagan effect” (Hartz & Chappell, 1997), where individuals who do outreach are thought to do less rigorous research by peers. Besides, researchers believe the public is disinterested in science and there is doubt whether scientists or an intermediary should be responsible for outreach. Finally, institutes prioritise research and there is often little time to engage in outreach as well as a lack of reward for it (Ecklund).

Most astronomers have a positive attitude towards education and outreach, although

they spend less time on it than recommended (Dang & Russo, 2015). Personal motivations are the main drive to interact with the public but there is little institutional support (Sarperi, 2018), with seniority being another important factor (Entradas & Bauer, 2018).

Research Question

The main goal of this article was to explore what professional astronomers perceive to be the societal impact of astronomy and whether they incorporate it into their work. Previous research has been conducted on how astronomers engage with the public, as well as their motivations for it (see Ecklund; Dang & Russo; Sarperi; Entradas & Bauer; and Bastow, 2014). However, there is little research on astronomers’ concern about the wider impact of their work on society and if there is a systematic approach.

We presume that there is a discrepancy in the attitude of astronomers: They might believe that societal impact is important, but not incorporate it into their work. We expected the main method used to affect society are traditional outreach activities without defining a broader strategy.

Many factors might play a role in how any astronomer regards societal impact (e.g. seniority, field of expertise, socio-geographical-cultural demographics). To mitigate the influence of these factors, the

Gender	Age	Nationality	Based in	Academic position	Field
F	67	UK	South Africa	Professor	Variability stars
F	40	Lebanon	Lebanon	Assistant Professor	Mercury exosphere, comets
M	36	Russia	USA	Assistant Professor	Computational/theoretical astrophysicist
M	30	India	USA	Postdoc	Extragalactic, galaxy dynamics
M	49	USA	The Netherlands	Professor	Galaxy evolution, stellar populations of galaxies, instrumentation
M	59	Japan	Japan	Professor	Radio astronomy, Milky Way
M	43	UK	UK	(PhD) Director of corporate strategy	(Pola Aurora) Policy and strategy
M	61	Thailand	UK	(Postdoc) Diplomat science and technology	(Geology, crystallography) Science policy and communication
M	41	Chile	Chile	Associate Professor	Planetary atmospheres
F	24	Australia	The Netherlands	PhD Student	Galaxy formation and evolution

Table 1. Characteristics of the participant sample.

interviewees were carefully selected. However, the effect of such factors could not be investigated quantitatively. This is a small-scale exploratory study that should be built on in future research.

Data Collection and Analysis

The interviewees were selected to provide the best representation possible of the global professional astronomy community within the limited sample size. Four face-to-face interviews took place during the General Assembly of the International Astronomical Union in 2018 and six were conducted online. Details about the sample of interviewees is provided in Table 1. Ten semi-structured interviews were carried out to allow for comparison between interviewees and identify common narratives, and to explore relevant topics outside the interview questions (*DiCicco-Bloom & Crabtree, 2006*). “Professional astronomer” in this study is defined as a person who is affiliated with an astronomy research institute.

The interviews were recorded after informed consent from the participant. A list of questions formed the framework of the interview and care was taken to formulate questions in an open and non-lead-

ing manner. The interviews were structured around the interview protocol:

- Background of the participant
- Attitude towards societal impact of astronomy
- Attitude of their institute and colleagues
- Knowledge about different types of impact
- Approach in achieving societal impact
- Barriers in this approach and possible improvements

The recordings of the interviews were transcribed and common topics in the data were grouped in codes. These codes were assigned to overarching categories (Figure 1). After the codes were determined, the transcripts were analysed again and re-labelled if necessary to ensure rigorous data analysis.

Results

Types of Impact

Based on the examples mentioned by interviewees, the authors categorised six types of societal impact of astronomy: technology transfer, economic returns, education, knowledge creation, cultural dimension, and diplomacy (Table 2).

Societal Impact Efforts

All the interviewees engage in outreach activities that they feel contribute to society and some (N=5) feel that it is their duty to do so. Besides sharing discoveries in media, many participants give public talks. However, they agree that their own research generally does not have a real impact on society (N=9).

Despite the active role taken by the participants, some (N=3) question who is responsible, researchers or an intermediary, for achieving impact. Furthermore, one interviewee thinks societal impact should not always be the main goal of research and that “there has to be room for things that are just interesting, impact does not need to drive it”.

All participants agree that societal impact is emphasised nowadays and it cannot be ignored. Seven of them know that their institutes include it in their mission. However, the answers to whether public engagement activities are appreciated are conflicted. The participants indicate that engaging in activities related to societal impact is generally appreciated by colleagues, although there is not always respect for it.

The sample expresses mixed opinions on whether the professional astronomy community wants to actively pursue societal impact. One participant believes that many astronomers like to do outreach, while another thinks that most are “worried about bugs in their code, rather than talking to the public”. If given the opportunity to do public engagement most would do it, but they would not seek it out.

Barriers and Improvements

Generally, the participants realise that creating societal impact with fundamental science is an unpredictable process (N=6) as “it’s hard to know what the impact will be of what you’re studying”. They mostly feel like they can spend time on societally-relevant activities within their job (N=6).

Participants indicate that a lack of funding is an obstacle to achieving societal impact (N=4), as well as the high workload of their job (N=3) and language (N=2). One interviewee mentions the competition between universities as an obstruction.

The main reported improvement is the inclusion of minorities and diversity (N=5). Some participants (N=4) mention the accessibility of astronomy (“Science needs to feel familiar to people.”), and only one participant has concerns about potential negative impact and emphasises the need for two-way communication (“Try to have a dialogue with them, not just explain.”). Assessment of societally-impactful activities that the participants engage in is often only done informally and without structure (N=7).

Conclusion

The professional astronomers in this study are aware of the different ways astronomy can impact positively on society. They deem societal impact important and are motivated to communicate with the general public, mainly through talks and classroom activities, and feel like they have time for doing so. Beyond the general public, they have few connections with industry or policymakers. Self-reported barriers in achieving societal impact include high workload, priority on research tasks, lack of funds and language barriers. Besides, they realise that societal impact is difficult to measure due to the serendipitous nature of discoveries in astronomy (Ecklund, 2012). According to the participants, astronomers could improve on achieving impact by making research more accessible and being more inclusive with underrepresented groups.

The activities that the interviewees undertake to achieve impact are mostly one-way exchanges with the general public and there are few efforts to interact with non-scientific stakeholders. Moreover, they encounter barriers and there is no structured approach in their public engagement activities like for research. They know about the potential societal impacts of astronomy but do not have all the tools to incorporate it into their work.

Even though no rigorous conclusions can be drawn based on the limited sample size, the results indicate that professional astronomers might not incorporate adequate activities into their job to achieve societal impact. Training astronomers to adopt a backwards approach, where the desired societal impacts of an activity are defined first, could be part of the solution.

References

Bastow, S., P. Dunleavy, and J. Tinkler, ‘The impact of the social sciences: how academics and their research make a difference’, SAGE Publications Ltd., 2014

Bornmann, L., ‘What is societal impact of research and how can it be assessed? A literature survey’, Journal of the American Society for Information Science and Technology, vol. 64, no. 2, 2013, p. 217-233

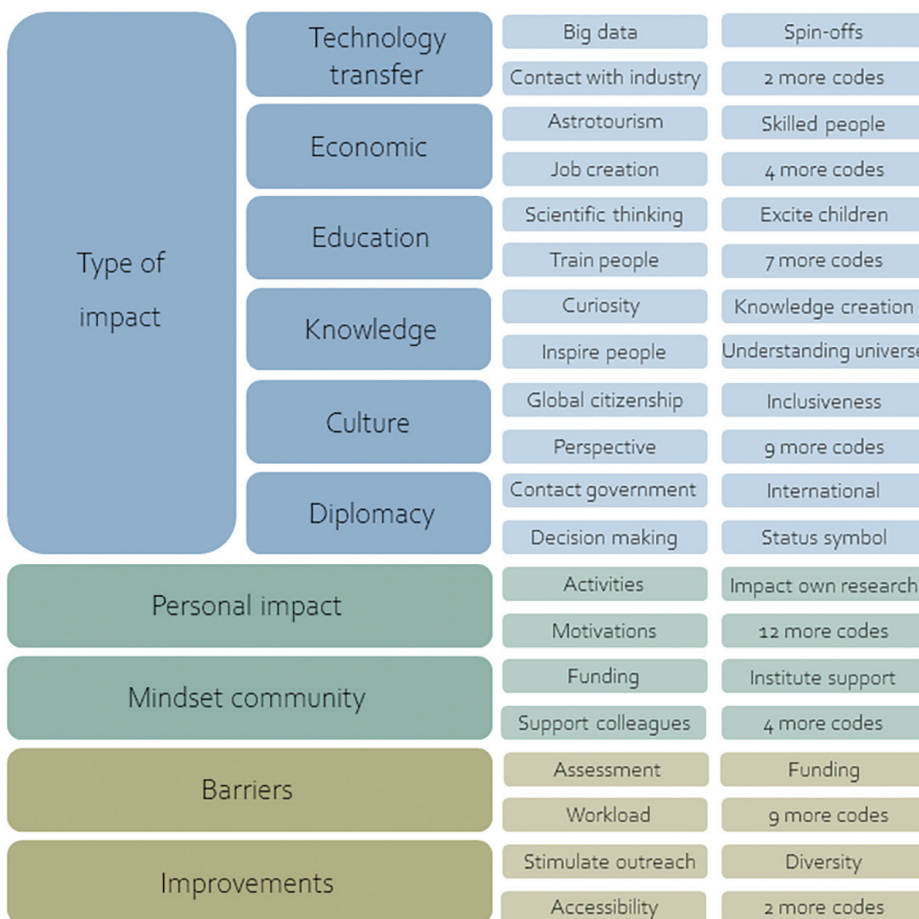

Figure 1. A visualisation of the categories and codes obtained in the data analysis of the interview transcripts. The categories (left column) consist of types of impact, personal impact, the mindset of the community, barriers and opportunities for improvements reported by the interviewees. A selection of the corresponding codes (middle and right column) are provided for each category. Credit: Michelle Willebrands

Category	Impact	N = x
Technology transfer	Spin-offs	10
	Big data	5
Economic benefits	Acquired skills	7
	Astrotourism	5
	Job creation	2
Education	Attract children to science	8
	Critical thinking	7
	Counteract misinformation	6
	Human capital	5
Knowledge creation	Inspire	10
	Understanding the world	7
	Societal Advancement	2
Cultural	Perspective	6
	Inclusiveness and diversity	5
	Global citizenship	3
	Appreciation of Earth	3
Diplomacy	International collaboration	4
	Decision-making	3
	Research infrastructures	2

Table 2. Overview of the types of impacts of astronomy on society mentioned by the interviewees, per category. The right column shows the number of interviewees out of the sample of 10 that mentioned each impact.

Dang, L. and P. Russo, 'How Astronomers View Education and Public Outreach: An Exploratory Study', *Communicating Astronomy with the Public*, vol. 18, 2015, p. 16-21

Davoust, E., 'The purpose of astronomy', *Vistas in Astronomy*, vol. 35, 1995, p. 315-322

DiCicco-Bloom, B. and B.F. Crabtree, 'The qualitative research interview', *Medical Education*, vol. 40, no. 4, 2006, p. 314-321

Ecklund, E.H., S.A. James, and A.E. Lincoln, 'How academic biologists and physicists view science outreach', *PLoS ONE*, vol. 7, no. 5, 2012, :e36240

Entradas, M. and M.W. Bauer, 'Bustling public communication by astronomers around the world driven by personal and contextual factors', *Nature Astronomy*, no. 3, 2018, p. 183-187

Fabian, A., 'The impact of astronomy', *Astronomy & Geophysics*, vol. 51, no. 3, 2010, p. 3.25-3.30

Hartz, J. and R. Chappell, 'Worlds apart: how the distance between science and journalism threatens America's future', *Freedom Forum First Amendment Center*, 1997

Llewellyn Smith, C., 'The use of basic science: Benefits of basic science', 2008, <https://public-archive.web.cern.ch/en/About/BasicScience1-en.html>

McBride, V. et al., 'The potential of astronomy for socioeconomic development in Africa', *Nature Astronomy*, vol. 2, July 2018, p. 511-514

Meijer, I., 'Societal returns of scientific research—How can we measure it?', Centre for Science and Technology Studies, Leiden University, 2012, CWTS-WP-2012-014

Rosenberg, M. et al., 'Astronomy in Everyday Life', *Communicating Astronomy with the Public Journal*, vol. 14, 2014, p. 30-35

Sarperi, S., J. Cramer, and P. Russo, 'Wat moet ik met het publiek?', *Nederlands tijdschrift voor Natuurkunde*, April 2018

Schneider, R., 'Science impact: Rethinking the Impact of Basic Research on Society and the Economy', *Bridges*, 2007, vol. 14

Biography

Michelle Willebrands is the project manager of the International Astronomical Union's (IAU) European Regional Office of Astronomy for Development (E-ROAD) at Leiden Observatory. She is the lead on the Advocacy and Legacy work package of the H2020 spaceEU project.

Pedro Russo is a professor in Astronomy & Society at Leiden University, the Netherlands. He coordinates the Astronomy & Society group at Leiden Observatory, which implements global-scale projects in astronomy, space education and public engagement.

Highlights in the Implementation of the AstroBVI Project to Increase Quality Education and Reduce Inequality in Latin America

Maria Argudo-Fernández

Instituto de Física, Pontificia Universidad Católica de Valparaíso (PUCV)
maria.argudo@pucv.cl

Nicolas Bonne

Institute of Cosmology and Gravitation (ICG), University of Portsmouth (UP)
nicolas.bonne@port.ac.uk

Coleman Krawczyk

Institute of Cosmology and Gravitation (ICG), University of Portsmouth (UP)
coleman.krawczyk@port.ac.uk

Jen Gupta

Institute of Cosmology and Gravitation (ICG), University of Portsmouth (UP)
jennifer.gupta@port.ac.uk

Alexis Rodríguez Quiroz

AstroBVI project Peru
alexiserquiroz@gmail.com

Penélope Longa-Peña

Centro de Astronomía (CITEVA), Universidad de Antofagasta
penelope.longa@uantof.cl

Juan Pablo Colque-Saavedra

Centro de Astronomía (CITEVA), Universidad de Antofagasta
juanpablo.colque@uantof.cl

Médéric Boquien

Centro de Astronomía (CITEVA), Universidad de Antofagasta
mederic.boquien@uantof.cl

Eduardo Unda-Sanzana

Centro de Astronomía (CITEVA), Universidad de Antofagasta
eduardo.unda@uantof.cl

Amelia Ortiz-Gil

Astronomical Observatory, University of Valencia
amelia.ortiz@uv.es

Ángela Pérez-Henao

Parque Explora, Planetario de Medellín
angela.perez@parqueexplora.org

Guilherme Couto

Centro de Astronomía (CITEVA), Universidad de Antofagasta
guilherme.couto@uantof.cl

Alessandro Martins

Federal University of Jataí/Universidade Federal de Goiás
alexm@ufg.br

Keywords

Astronomy, Education, Inclusion, Galaxies

AstroBVI is an inclusive astronomy project funded by the International Astronomical Union Office of Astronomy for Development (IAU OAD). AstroBVI has been designed for the blind and visually impaired (BVI) community, who are often excluded from outreach and educational activities concerning visually-intensive areas of knowledge such as astronomy. In this project we aim to break down the barriers between science and ability, and to bring astronomy's beauty to a visually-impaired public, independently of gender, wealth and social status. We have created and distributed educational kits composed of 3D tactile maps of galaxies accompanied by a manual and multimedia material in Spanish and Portuguese. Our kit has been mainly distributed to Latin American countries, where we have created a community of AstroBVI teachers. We present the project and highlight some of the activities carried out by this community.

The AstroBVI Project

AstroBVI¹ originated from a one-minute lightning talk presentation by Dr Nicolas Bonne from the University of Portsmouth during the annual meeting of the MaNGA² collaboration at the University of Wisconsin–Madison in 2015. During his talk, he presented the pilot version of the Tactile Universe project³, showing a prototype of a 3D-printed tactile galaxy image and explaining how they were working with their local BVI community. Dr Maria Argudo-Fernández, from the University of

Antofagasta at that time, returned to Chile with the aim of implementing the project in the Spanish-speaking community and reaching as many school children as possible. She gathered a team composed of collaborators around the world, including professional astronomers and specialists in education and inclusion as well as partner projects such as A Touch of the Universe⁴ and Astronomy with all Senses⁵ to produce materials with 3D printers in the astro-engineering lab of the university. The path to achieve our goal was ambitious: to create and distribute as many educa-

tional kits as possible to teachers and science communicators in different countries in Latin America. We started the project thanks to funding in 2018 from the IAU OAD⁶.

The AstroBVI Kit

The AstroBVI educational kit is composed of 3D printed tactile images of different galaxies in different light wavelengths (colours), created using 3D model files provided by the Tactile Universe team,

a collaboration that was central to the AstroBVI project.

The Tactile Universe 3D galaxy images were developed in consultation with a local BVI support group in Portsmouth, England and were created by converting a single-band (i.e. single colour) image of a galaxy into a height map: the brighter an image pixel was, the taller its representation was on the tactile image. A full description of the initial development and pilot phase of the Tactile Universe project can be found in Bonne et. al. (2018). Tactile Universe provided these files to AstroBVI in advance of their public release³, and therefore AstroBVI drew closely upon the Tactile Universe team's experience and resources, including adapting and translating written material into Spanish and Portuguese.

The sample of galaxies composing the AstroBVI kit was selected according to their morphology to have one type of each galaxy in the Hubble fork morphological diagram, as shown in Figure 1. The AstroBVI kit is therefore composed of tactile images of the following galaxies:

- M100: a face-on spiral galaxy with no bar observed in the photo-metric B-band;
- M109: an inclined barred spiral galaxy observed in the B-band;
- M51: a face-on galaxy merger of a spiral and an elliptical galaxy, observed in the R-band and B-band;
- M105: an elliptical galaxy observed in the R-band;
- NGC5866: a lenticular galaxy observed in the R-band.

The kit includes the corresponding Digital Sky Survey (DSS) images of the galaxies used to create the 3D tactile images, coloured images of the galaxies, a guide to help with touching each galaxy (text and audio formats), two guided activities for teachers and a video-manual. All multimedia material is hosted on the website of the project⁷ in Spanish and Portuguese. The 3D galaxy models for printing are also freely available under a Creative Commons (CC BY-NC-ND 4.0) license⁸.

With the available funding, we created and distributed 100 kits to what we named the AstroBVI Teachers Community.



Figure 1. Elements composing the AstroBVI kit (tactile images, galaxy pictures, galaxy guide, and bag). Image Credits: AstroBVI project

The AstroBVI Teachers Community

The kits were distributed to a selection of teachers and science communicators based on motivation, impact and representation in as many countries as possible. Teachers submitted applications online, which were then reviewed by members of the AstroBVI team, who gave a score of 1 to 5 aforementioned criteria.

Latin American countries are in general developing countries with high economic inequalities and many socio-economic challenges, where the resources are very centralised in the capitals and larger cities. Fortunately the AstroBVI teachers are not concentrated in these areas. They are running many different activities (e.g. stands, workshops, school lessons) at many different levels (children, general public, pro-

fessional, and scientific community) using the AstroBVI kit. The selection process aimed to evenly distribute kits across gender, wealth and social status. In fact, 50% of the AstroBVI teachers are women.

The selection was also done independently of an applicant's level of knowledge of astronomical concepts (Argudo-Fernández et al., 2019). We therefore held two virtual workshops to train AstroBVI teachers, one on astronomy and one on inclusion. These workshops included how to effectively work with the kit in the classroom, starting with easy concepts (e.g. planets and distances) then gradually moving onto more complex ones (e.g. galaxy formation). The workshops were delivered in collaboration with the Galileo Teacher Training Program⁹, and the lessons are publicly available¹⁰.

The selected teachers composed the AstroBVI Teachers Community. They are mainly distributed in Latin American countries (Argentina, Bolivia, Brazil, Chile, Colombia, Costa Rica, Ecuador, Honduras, México, Paraguay, Peru and Venezuela), but also in Spain and Nepal.

Astronomy for Development

Among all the countries where we distributed our kit, we would like to highlight the experiences from Chile and Peru. Chile submitted the largest number of applications in our global call (Argudo-Fernández, 2019), especially for the primary and secondary school level. Peru submitted only two applications, but this resulted in the presence of inclusive astronomy activities in Peru for the first time, generating a high impact.

AstroBVI in Chile

Chile is a Latin American country with a large and growing astronomical community (Chilean Astronomical Society, 2019). It is also a country with a growing community in astronomy and inclusion (Núcleo de Astronomía UDP, 2019). Thanks to the AstroBVI teachers, different types of activities (e.g. exhibitions, stands, workshops) are being held throughout the country.

Through the actions of seven core members of the AstroBVI team, all of whom are located in Chile, the project has pushed high-level activities for inclusive astronomy in the country. During the first stages of the project AstroBVI in Chile joined the Astronomy for All group, which shows different initiatives of inclusive astronomy in Chile. With them the team participated in an IAU Inspiring Stars exhibition¹¹. This collaboration has since grown into an interdisciplinary working group on astronomy and inclusion composed of more than 50 participants in the last year (*Núcleo de Astronomía UDP*). The membership¹² have identified some problems and challenges with respect to the public education system¹³, and we are working together on building a culture of inclusion through dissemination and education in astronomy to expand inclusion into other scientific disciplines.

Among the activities the working group are carrying out, we are collaborating with the Giant Magellan Telescope¹⁴ and Ecoscience Foundation¹⁵ in the creation of a manual for educators in Chile on inclusive astronomy, which we plan to give to vulnerable schools, mainly located in rural areas. We are collecting the successful experiences from our inclusive astronomy activities to create this manual, which will be written for teachers of public schools

who teach students with different abilities¹⁶.

AstroBVI in Peru

AstroBVI in Peru demonstrated to the public and politicians the incredible potential for people, regardless of their condition, status or age, to learn about the universe, making a remarkable leap for astronomy education in Peru. The tactile materials gave BVI participants the opportunity to become interested in science and especially astronomy. In 2019, seven AstroBVI workshops were held in Lima, one every month between April and November (Figure 2), with 165 BVI participants from 6 to 75 years old, 21% of whom were women and girls. The workshops were held in public libraries and schools. In each session, attendees met for two hours to learn about the wonders of space.

It is worth noting that basic science education for students with visual impairments in Peru is minimal due to the lack of teaching material and limited academic curriculum available in schools. Therefore, the AstroBVI workshops have enormously helped students understand the place of our planet in the universe. Through qualitative evaluation, many participants said that it was the first time they understood what a galaxy is and how they look or learnt about the size of the planets, the solar system and other astronomical objects.

The AstroBVI teachers said that the project has also had an impact on them, showing them that astronomy can be inclusive—that no disability matters if someone wants to learn. With the right tools, patience and willpower, the knowledge of the universe can be held in anyone's hands.



Figure 2. Image from one of the activities carried out by AstroBVI teachers in Peru in 2019. Credit: Alexis Rodríguez Quiroz/AstroBVI project

References

- Argudo-Fernández et al., "AstroBVI: An Astronomical educational kit for the Blind and Vision Impaired community in Latin America", *Boletín de la Asociación Argentina de Astronomía*, vol. 61a, 2019, p.268-270
- Bonne, N.J. et al., "Tactile Universe makes outreach feel good", *Astronomy & Geophysics*, vol. 59, 2018, p. 1.30

'Censos de Astronomos', Chilean Astronomical Society (SOCHIAS) [website], 2019, <https://sochias.cl/censos-de-astronomos/>

'Primera reunión del Grupo de Astronomía Inclusiva se realizó en la UDP', Núcleo de Astronomía Universidad Diego Portales (UDP) [online], 20 December 2019, <https://astronomia.udp.cl/es/espanol-primera-reunion-del-grupo-de-astronomia-inclusiva-se-realizo-en-la-udp/>

Notes

- 1 AstroBVI website: www.astroBVI.org
- 2 Mapping Nearby Galaxies at Apache Point Observatory (MaNGA) website: <https://www.sdss.org/surveys/manga/>
- 3 All the 3D printing files and associated lesson plans and materials are available to download for free from the Tactile Universe website: www.TactileUniverse.org
- 4 A Touch of the Universe website: <https://astrokit.uv.es>
- 5 Astronomy with all Sense reports and material on the IAU OAD website: <http://www.astro4dev.org/blog/category/tf3/astronomy-with-all-senses/>
- 6 Project reports and materials are available on the IAU OAD website: <http://www.astro4dev.org/blog/category/tf2/astrobi-an-astronomical-educational-kit-for-the-blind-and-vision-impaired-bvi-community-in-south-america/>
- 7 Multimedia material hosted on the AstroBVI website: <https://www.astroBVI.org/profes>
- 8 Attribution-NonCommercial-NoDerivatives 4.0 International license information: www.creativecommons.org/licenses/by-nc-nd/4.0/
- 9 Galileo Teacher Training Program: www.galileoteachers.org
- 10 Galileo Teacher Training Program lessons: www.youtube.com/channel/UC4Ad_VHSsqJfYat7sqcePOg
- 11 Inspiring Stars website: sites.google.com/oao.iau.org/inspiringstars
- 12 Members include astronomers, science journalists, anthropologists, public administrators, as well as people of various other disciplines.
- 13 Some of these problems include a lack of training and resources for supporting teachers of students with different disabilities or special needs, and a lack of even distribution of the resources available. We received a number of requests for an AstroBVI kit from Chilean PIE teachers, where their motivation was a need for materials and training in case they received a student with blindness in their class. More information regarding the state of special education in Chile can be found in Spanish here: <https://repositorio.uc.cl/handle/11534/15764>

¹⁴ The Giant Magellan Telescope: www.gmto.org

¹⁵ Ecoscience Foundation: <http://www.ecoscience.org/>

¹⁶ These teachers are known as PIE teachers, by the acronym in Spanish of School Integration Program.

Acknowledgements

We acknowledge invaluable help and support of our partner projects: Tactile Universe, A Touch of the Universe, Astronomy with All Senses, Dedoscopio, Breaking the Silence, and Breaking the Barriers. Special thanks to all the AstroBVI teachers for bringing astronomy where we can't in an inclusive way. We would also like to thank the Chilean Astronomical Society (SOCHIAS), REUNA, Star Tres, and Astrofísicos en Acción for their support. We acknowledge the IAU Office of Astronomy for Development, which funded the AstroBVI project during 2018 and part of 2019. We would also like to acknowledge funding from the FONDECYT regular project 1170618.

Biography

María Argudo Fernández is an astrophysicist at the Institute of Physics of the PUCV, in Chile. Her research aims to understand the effects on the environment on galaxy formation and evolution. She is involved in astronomy outreach activities and leads the AstroBVI project.

Nicolas Bonne is an astrophysicist and science communicator at the ICG of the UP. His main research interest is on Galaxy Evolution. He leads the Tactile Universe, developing materials to engage vision impaired and blind people with current astronomy research.

Coleman Krawczyk is an astrophysicist at the ICG of the UP. He is involved in The Tactile Universe as Technical Lead.

Jen Gupta is the Public Engagement and Outreach Manager for the ICG at the UP. She oversees the ICG's strategic outreach and public engagement programme, including running the school visits, supporting ICG members to do public engagement activities, and evaluating the impact of this work. She is the public engagement advisor for the Tactile Universe.

Alexis Rodríguez Quiroz, physicist at the Universidad Nacional Mayor de San Marcos, worked in the Direction of Hydrography and Navigation of Peru and in the Space Agency of Peru. Participated in the 2016 Latin American School of Observational Astronomy (ESAOBELA) and The 2018 International School for Young Astronomers (ISYA).

Penélope Longa-Peña is an astrophysicist at Universidad de Antofagasta (Chile). She is currently studying orbital parameters of Compact Binary Stars.

Juan Pablo Colque-Saavedra is the coordinator of the astro-engineering laboratory of the University of Antofagasta. He is involved in the AstroBVI project as a Technical Lead.

Médéric Boquien is currently an Associate Professor at Universidad de Antofagasta (Chile). He obtained his doctorate from Université Paris VII (France) and subsequently had postdoctoral stays in the USA, France, and the UK. He studies the formation and evolution of galaxies using both multi-wavelengths observations and models.

Eduardo Unda-Sanzana is an Associate Professor and current director of the Center of Astronomy (CITEVA) at Universidad de Antofagasta. Since completing a PhD in Astronomy at University of Southampton (2005) he has managed several high-level projects including the development of the Koirama Observatory and region-wide outreach efforts.

Amelia Ortiz-Gil is an astronomer working in outreach and education at the University of Valencia in Spain. She is an award-winning astronomy communicator, creating the groundbreaking BVI kit "A Touch of the Universe". She is the chair of the International Astronomical Union (IAU) Working Group of Astronomy for Equity and Inclusion and is the IAU National Outreach Coordinator for Spain.

Ángela Patricia Pérez Henao is an astronomer and educator at the Medellín Planetarium in Colombia. She coordinates the astronomy and education working group (TF2) of the Andean OAD region, developed the Astronomy with all the Senses suitcase, and supports teacher training programmes for astronomy.

Guilherme Couto is a postdoc at Universidad de Antofagasta. He got his PhD at UFRGS in Porto Alegre, Brazil in 2016. His main research interests are galaxy evolution and active nuclei, and he is also interested in any outreach program he feels can contribute to, such as AstroBVI.

Alessandro Martins is a physicist, research at the Federal University of Jataí in Brazil. He does outreach activities as a science and astronomy communicator. He created the Rediscovering Astronomy project with activities in midwest Brazil.

Astro Molo Mhlaba: A Sustainable Approach to Inclusivity in Astronomy

Margherita Molaro

University of the Western Cape
margherita.molaro@gmail.com

Rethabile Mashale-Sonibare

Molo Mhlaba School
molo@molomhlaba.org

Keywords

Education, Inclusivity, Girls, South Africa, STEM

One of the major difficulties facing interventions tackling inclusivity in astronomy is the extremely wide range of factors that simultaneously need addressing. Efforts to provide support at a particular phase of an individual's academic or professional career can in fact be nullified if no support is provided at the subsequent phase. In order to tackle this, the Astro Molo Mhlaba programme, which works with girls and women in underserved communities in Cape Town, South Africa, has introduced an innovative and sustainable approach, which ensures that development can be consistently provided at all stages of an individual's schooling and professional career. The school behind the programme, Molo Mhlaba, was founded and is led by local, award-winning activists with a six-year track record of well-established social and educational projects. Astro Molo Mhlaba's programmes were therefore specifically designed based on a first-hand understanding of the complex obstacles barring these girls from entering careers in astronomy.

Introduction

Calls to address the lack of representation of groups identified by their gender, race, and financial background in research, which has been widely documented in STEM (science, technology, engineering, and maths) fields (*Campaign for Science and Engineering, 2018*), have been motivated in several ways.

The most fundamental of all is that the exclusion of these groups is the result of entrenched structural barriers in our societies, ultimately rooted in the discrimination and economic inequality these groups face (*van der Berg, 2005*). Addressing the issue of inclusivity in astronomy, therefore, is to engage in a broader effort to ultimately bring about a fairer and better society.

Other arguments refocus this discussion around the well-documented benefits that a more diverse workforce can bring to the research itself (*Hunt, 2018; D'Ath*).

There is however another way in which promoting the inclusivity of largely underrepresented groups can benefit astronomy: Ensure that research positions are taken by the most brilliant minds in order to maintain the highest standards in the field. But how can we make sure the best people get the best positions if we do not sample from

the full population's potential distribution? In other words, how do we ensure that the largest possible number of people are able to enter the race for research positions, so that it is statistically more likely for these positions to be occupied by the very top performers?

Evidence shows that this distribution of potential is utterly unaffected by factors such as gender, race, and economic background (*Guiso, 2008; Balart & Oosterveen, 2019*), despite continued exclusion of people marginalised by these factors. This points to an answer to the above question: By addressing the lack of representation of marginalised groups identifiable by these variables.

This article discusses the work of Astro Molo Mhlaba (AMM), which focuses on the inclusion of the most underrepresented group in South African science: black girls from underserved communities¹.

When to Intervene?

Today, despite representing 41% (*Statistics South Africa, 2019a*) of the population, black women constitute only 0.06% of STEM university graduates².

Anyone bringing them to the race's start line—which we identify as success-

fully enrolling at university in a STEM degree—requires an understanding of the obstacles they face in getting there (*Astro Molo Mhlaba*). These obstacles are severe, numerous, diverse, complex and inter-linked, and are further present at all stages of their personal and academic development. A difficult question to answer then is when is the best stage at which to intervene?

Efforts to provide support at an early phase of an individual's academic or professional career can be undermined if no support is provided at the subsequent phase. Starting from a fragile foundation can lead to no real changes over generations for many individuals, and can also result in extremely ineffective efforts at later stages (*García, 2019*).

For this reason, our approach has been to provide support for students at all stages of their development, from 5 to 20 years old, in order to ensure the sustainability of our interventions.

Astro Molo Mhlaba (AMM)

The Molo Mhlaba school³ behind the AMM programme is a network of local, low-fee⁴, independent schools in underserved communities in Cape Town, South Africa. It provides the country's most vulnerable group—black girls from

underserved communities—with unprecedented access to high-quality STEAM (where A stands for “arts”) education and career orientation. Molo Mhlaba believes that girls living in underserved communities have a right to a safe, affordable and quality education to be inspired to pursue STEM subjects and work hard towards achieving their goals.

In 2019, the school launched the AMM project⁵ with the aim of creating exposure to astronomy for girls at the school as well as neighbouring schools. Astronomy easily captures the imagination of students of all ages, making it the ideal subject through which to encourage these young girls to pursue STEM careers.

AMM was structured around the following programmes, which we were able to realise thanks to the support of our sponsors, the International Astronomical Union Office of Astronomy for Development (IAU OAD) and the University of the Western Cape (UWC):

Astro Club: Weekly after-school programmes for primary school girls which engage them in fun and creative astronomy activities. The aim of this programme is to:



Figure 1. Students in Astro Academy think of different ways to verify that the Earth is round during a visit from Dr. Marisa Geyer of the South African Radio Astronomy Observatory. Credit: Astro Molo Mhlaba

- Transmit fundamental astronomy concepts to young girls;
- Promote an association of astronomy with enjoyable and stimulating activities;
- Develop the girls’ confidence in approaching scientific subjects to empower them to pursue their scientific curiosity with assurance.

Astro Academy: Weekly after-school classes and a STEM-career mentorship

programme for Grade-11 students with excellent grades in maths and physics. The lessons are taught by female astronomers, who also provide advice and support on how to pursue a degree and a career in science. The activities are structured around their school curriculum (Figure 1).

Facilitator programme: Bursary programme for female graduates with good grades in maths and physics who have not enrolled at university. They attend the Academy classes, are trained and paid to run the Astro Club activities, and receive career advice and support for their next step. There are currently four facilitators.

Network: The AMM programme goes well beyond Molo Mhlaba, and actively works to involve more local schools in underserved communities in its initiatives. The programme currently collaborates with five neighbouring schools in the communities of Khayelitsha & Philippi in Cape Town. Across Molo Mhlaba and the neighbouring schools, about 230 girls and women have taken part in AMM programmes.

Astro festivals: Events on astronomy and STEM careers organised for children, their parents and the wider community. Through these, girls from the Astro Club can showcase what they have learnt to their parents and peers, increasing their confidence and enthusiasm in the programme. Children and parents alike can learn more about not only astronomy, but also about the career



Figure 2. Girls from the Chumisa Primary School’s Astro Club showcase what they have learnt about the planets in the solar system to their parents, fellow students, and astronomers during the Molo Mhlaba Astro Festival, which celebrated the IAU Astronomy Day in Schools. Credit: Tasman Weir



Figure 3. Palesa Nombula, a commercialisation young professional at the Square Kilometre Array and astrophysicist, speaks with students and family at the Molo Mhlaba Astro Festival. Credit: Tasmin Weir

options offered by a degree in the scientific research field (Figure 2, Figure 3).

Our Strategy

The programmes previously outlined were designed to simultaneously tackle a number of barriers, which take place at different stages of girls' personal and academic development, by doing the following:

Break down Early Internalisation of Gender Stereotypes

In South Africa, like many other places in the rest of the world, social influences and gendered toys (*The Institution of Engineering and Technology, 2016*) translate into early internalisation, by children of both genders, of a presumed lack of potential in girls to successfully engage in science- and maths-based activities. We ensure that from an early age girls are directed away from this stereotype.

Transform Internalised Stereotypes of Subject Choice

Gender stereotypes can dangerously affect teenage girls who, despite obtaining excellent results in maths and science, may shy away from pursuing those subjects for fear of being less talented than their male peers (*Institute of Physics, 2012*). By having female astronomers teach in the Academy, we are able to provide the girls with hard evidence that women can be scientists too.

Increase Understanding of Pursuing a Career in Science

A major contributor to exclusion from STEM fields is the concern around the financial stability of a career in STEM, compounded by a lack of understanding of what a career in STEM actually is. We provide information to parents and pupils in underserved communities on how a career in STEM provides skills—both direct and transferable—which are highly sought-after in research and industry alike.

Address a Lack of Funding to Attend University

University fees are prohibitive for many students from underserved communities (*Statistics South Africa, 2019b*). However,

many funding opportunities are offered by the South African Radio Astronomy Observatory (SARAO) for higher degrees in physics to excellent students with an interest in astronomy. By engaging high school girls in astronomy activities, we can both motivate them to pursue a degree in physics, give them useful experience to include in their CV, and provide them with support at the time of application.

Provide Career Guidance at the Time of Graduation

Through our Facilitator programme, we are able to give a second chance to girls that, despite graduating successfully from high school, did not enrol at university because it was never considered as a viable option or they lacked understanding of how to do so practically. By incentivising them with a steady income while teaching the Club, we provide them with the support and guidance necessary to apply to university the following year.

Conclusions

Truly caring about the quality of science we produce comes hand-in-hand with ensuring that research positions are occupied by the very best in the population's pool of scientific talent. Those top performers, however, are statistically less likely to be found if a great portion of this pool is excluded prior to the selection process.

Astro Molo Mhlaba wants to ensure that the top talent in one of the most under-represented groups in South African science—black girls from underserved communi-



Figure 4. Header for the Molo Mhlaba Astronomy Facebook page. Credit: Astro Molo Mhlaba; Sky Image Credit: A. Das



Figure 5. The girls in Astro Molo Mhlaba talk with Ewine van Dishoeck, president of the International Astronomical Union and Leiden University professor. Credit: Astro Molo Mhlaba

ties—are not missed. In order to ensure its efforts are truly sustainable, its interventions simultaneously target obstacles present at all stages of these girls' personal and academic development—from their early years of primary schooling, through their high school studies, and after their graduation from school.

We want Astro Molo Mhlaba to become a permanent, well established programme in Khayelitsha, and eventually expand to reach more schools in the community⁶. Only in its second year of implementation, the programme has high hopes that the young girls taking part in our initiatives today will one day be able to fulfil their true scientific potential, and contribute to the future success of astronomical research.

References

Astro Molo Mhlaba, 'Why Girls?', Astro Molo Mhlaba [website], www.astromolomhlaba.org/why-girls (Accessed 15 Jan 2020)

Balart, B., and M. Oosterveen, 'Females show more sustained performance during test-taking than males', *Nature Communications*, 3798 (2019), 2019

van der Berg, S., 'Apartheid's enduring legacy: Inequalities to education', submitted to The South African Economic Policy under Democracy: A 10 year review conference, Stellenbosch, South Africa, 27-28 October 2005, Oxford University and University of Stellenbosch, 2005, <https://www.saide.org.za/resources/Library/VanderBerg%20-%20Apartheid%27s%20Enduring%20Legacy.pdf>

Campaign for Science and Engineering, 'CaSE policy review on Diversity 2018', Campaign for Science and Engineering (CaSE) [online], 20 February 2018, <http://www.sciencecampaign.org.uk/resource/diversity2018.html>

D'Ath, J., 'Why improving gender diversity in STEM should be a priority', *STEM Learning* [online], <https://www.stem.org.uk/news-and-views/opinions/why-improving-gender-diversity-stem-should-be-priority> (Accessed 15 January 2020)

García, E. and E. Weiss, 'Education inequalities at the school starting gate: Gaps, trends, and strategies to address them', *Economic Policy Institute* [online], 27 September 2019, <https://www.epi.org/publication/education-inequalities-at-the-school-starting-gate/>

Hunt, V. et. al., 'Delivering through diversity Report', McKinsey & Company [online], January 2018, https://www.mckinsey.com/~media/McKinsey/Business%20Functions/Organization/Our%20Insights/Delivering%20through%20diversity/Delivering-through-diversity_full-report.ashx

Guiso, L. et. al., 'Culture, Gender, and Math', *Science*, vol. 320, no. 5880, 2008, p. 1164-1165

The Institution of Engineering and Technology, 'Parents, retailers and search engines urged to 're-think the pink' next Christmas', The Institution of Engineering and Technology [online], 06 December 2016, <https://www.theiet.org/media/press-releases/press-releases-2016/06-december-2016-parents-retailers-and-search-engines-urged-to-re-think-the-pink-next-christmas/>

Institute of Physics, 'It's Different for Girls: The influence of schools', Institute of Physics [online], October 2012, http://www.iop.org/education/teacher/support/girls_physics/file_58196.pdf

Statistics South Africa (2019a), 'Mid-year population estimates 2019', Statistics South Africa, Republic of South Africa [online], 29 July 2019, <http://www.statssa.gov.za/publications/P0302/P03022019.pdf>

Statistics South Africa (2019b), 'Education Series Volume V: Higher Education and Skills in South Africa, 2017', Statistics South Africa, Republic of South Africa [online], 2019, <http://www.statssa.gov.za/publications/Report-92-01-05/Report-92-01-052017.pdf>

Notes

- ¹ "Black" here refers to Black Africans in South Africa, rather than Coloured Africans in South Africa.
- ² No direct statistics are available, so the quoted number was obtained as follows: 13% of STEM graduates in South Africa are female ('The Global Gender Gap Report 2018—World Economic Forum', World Economic Forum [online], 1 Oct 2018, <https://www.weforum.org/reports/the-global-gender-gap-report-2018>)
- ³ Of 200 black pupils who start school, only one can expect to do well enough to study engineering ('South Africa has one of the world's worst education systems', *The Economist* [online], 7 Jan 2017, <https://www.economist.com/middle-east-and-africa/2017/01/07/south-africa-has-one-of-the-worlds-worst-education-systems>)
- ⁴ Molo Mhlaba school website: <https://molomhlaba.org/>
- ⁵ There are school fees required for both public and private schools, with public schools having widely varying levels of government support and academic rigour. The school fees for private Molo Mhlaba were based on the 2018 amount of government-paid child support grants, guidance from the Khayelitsha Early Childhood Development Forum, and a survey of over a hundred local parents. Based on a 3/3 system, parents only pay one-third of the true schooling cost, with grants, donations or sponsorships making up the remaining cost.
- ⁶ Astro Molo Mhlaba programme website: www.astromolomhlaba.org
- ⁷ People can support our program through monetary donations (www.astromolomhlaba.org/donate) or by remote volunteering to help with the development of material.

Biography

Margherita Molaro is a postdoctoral researcher at the Centre for Radio Cosmology of the University of the Western Cape in Cape Town, South Africa. She is the founder and coordinator of the astronomy outreach project Astro Molo Mhlaba (www.astromolomhlaba.org).

Rethabile Mashale-Sonibare



ASTRONOMY FOR COMMON HUMANITY

“ Look again at that dot.
That’s here. That’s home. ”

– CARL SAGAN

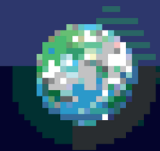

Astronomy for:
TOLERANCE • PEACE • GLOBAL CITIZENSHIP

A flagship program of the International Astronomical Union’s
Office of Astronomy for Development and the European Regional Office.
Pale Blue Dot was an IAU100 celebration from 13 – 20 Feb 2020.



www.bit.ly/3anQhx1



Colophon

Guest Editors

The IAU Office of Astronomy for Development (IAU OAD) Team

Editor-in-Chief

Lina Canas

Managing Editor

Izumi Hansen

Executive Editor

Hidehiko Agata

Layout and Production

Lina Canas
Mizuho Matsumoto

Contributors

Dhyan Adler-Belendez
Paul Akumu
María Argudo-Fernández
Sonal Asgotraa
Paul Baki
Nadia Bali
Brian Bichang'a
Julie Bolduc-Duval
Nicholas Bonne
Médéric Boquien
Leonardo Sattler Cassara
Juan Pablo Colque-Saavedra
Guilherme Couto
Nicolas Cowan
Carolyn Crow
Francesca Fragkoudi
Karolina Garcia

Jen Gupta
Paul Hayne
Neil Jacobson
Carringtone Kiyanjui
Coleman Krawczyk
Dennis Kulvinder
Mary Beth Laychak
Penélope Longa-Peña
Wladimir Lyra
Samyukta Manikumar
Jeffery Marlow
Alessandro Martins
Rethabile Mashale-Sonibare
Eric Meli
Margherita Molaro
Ismael Moumen
Kioko Mutisya
Simon Ndiritu
Alex Orieko
Amelia Ortiz-Gil
Bonface Osoro
Ana Pantelic
Andreas Papalambrou
Ángela Pérez-Henao
Melissa Rice
Alexis Rodríguez Quiroz
Laurie Rousseau-Nepton
Pedro Russo
Samar Safi-Harb
Eduardo Unda-Sanzana
Maurice Wafula
Michelle Willebrands

Editorial Board

Kimberly Kowal Arcand
Tawanda Chingozha
Richard Fienberg
Kaoru Kimura
Amelia Ortiz-Gil
Francisco Rodríguez
Amidou Sorgho
Ramasamy Venugopal

Web Design and Development

Raquel Shida
Gurvan Bazin

Address

CAPJournal,
IAU Office for Astronomy Outreach,
C/O National Astronomical Observatory of
Japan
2-21-1 Osawa, Mitaka, Tokyo, 181-8588
Japan

E-mail

editor@capjournal.org

Website

www.capjournal.org

ISSNs

1996-5621 (Print) | 1996-563X (Web)

License



This work is licensed under a Creative Commons License

CAP journal

Communicating Astronomy with the Public

Submission

We are keen to encourage readers to submit their own articles, reviews, and other content.

Submissions should be sent to the Editor:
editor@capjournal.org

www.capjournal.org

Online issues
Free subscriptions
Article submission

Publishers



Sponsors



Collaboration

