

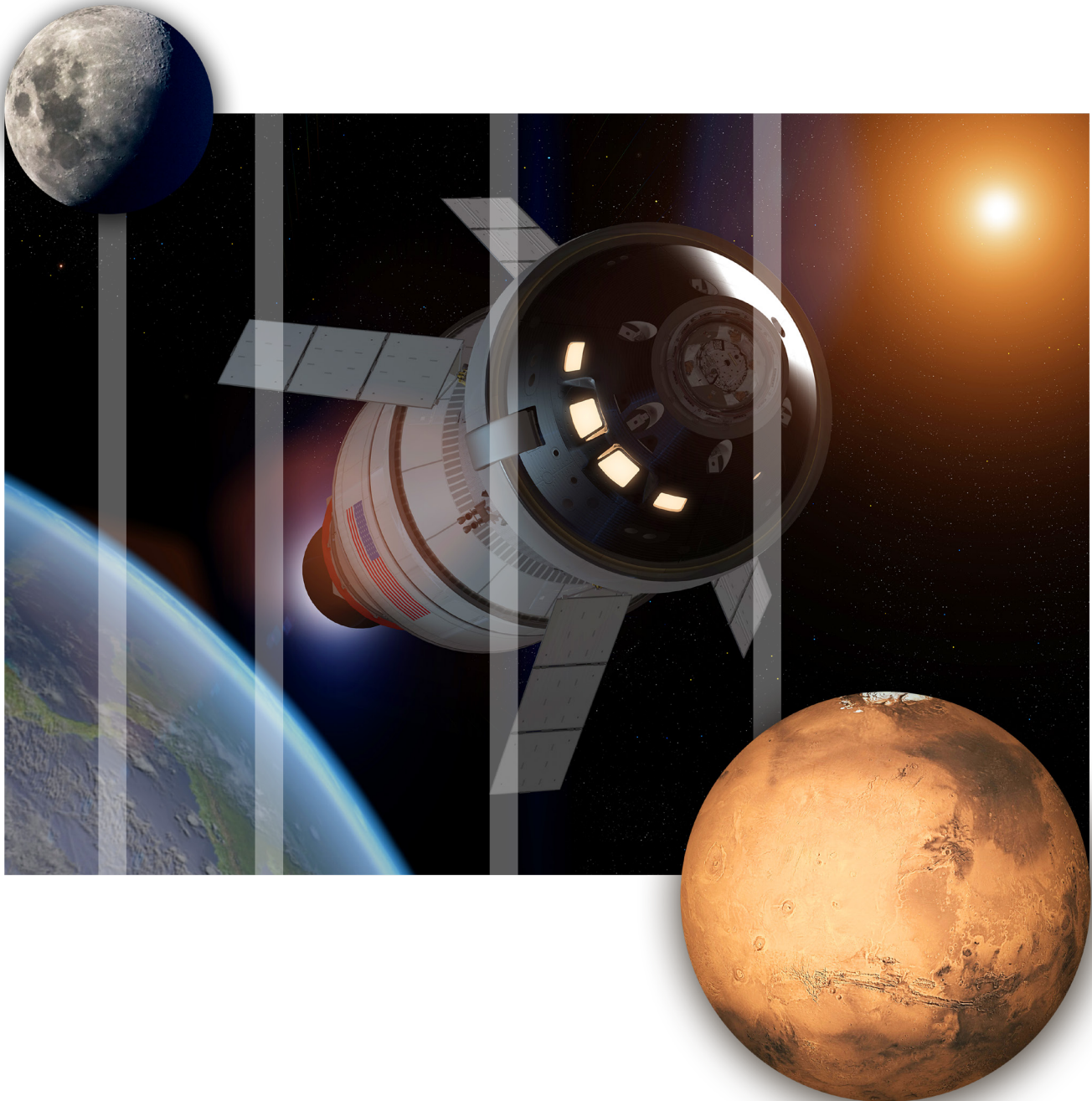

# Crew Transportation With Orion

## Educator Guide



Educator Guide	
Educators and Students	Grades 6 to 8



# Contents

<b>Preface</b> .....	<b>1</b>
<b>STEM Education Standards</b> .....	<b>1</b>
<b>Engineering Design Process</b> .....	<b>2</b>
<b>Introduction and Background</b> .....	<b>3</b>
Artemis Missions .....	3
Orion: Learning From the Past With Apollo .....	4
The Process of Creating the Orion Crew Module .....	6
How Does Friction Stir Welding Work? .....	6
Orion Docking Capabilities .....	7
<b>Activity One: Analyze the Geometry of a Spacecraft</b> .....	<b>8</b>
Educator Notes.....	8
Student Handout .....	12
<b>Activity Two: Design a Crew Module</b> .....	<b>14</b>
Educator Notes.....	14
Student Handout .....	17
<b>Activity Three: Model a Spacecraft Docking System</b> .....	<b>18</b>
Educator Notes.....	18
Student Handout .....	21
<b>Activity Four: Build a Heat Shield</b> .....	<b>29</b>
Educator Notes.....	29
Student Handout .....	33
<b>Appendix: STEM Standards and Practices</b> .....	<b>35</b>
Next Generation Science Standards (NGSS).....	35
NGSS Science and Engineering Practices.....	36
International Society for Technology in Education (ISTE) Standards for Students .....	36
Common Core State Standards (CCSS) for Mathematics.....	37





## Preface

*Crew Transportation With Orion* was published by NASA’s Office of STEM Engagement as part of a series of educator guides to help middle school students reach their potential to join the next-generation STEM workforce. The activities can be used in both formal and informal education settings as well as by families for individual use. Each activity is aligned to national standards for science, technology, engineering, and mathematics (STEM), and the NASA messaging is current as of September 2019.

## STEM Education Standards

The STEM disciplines matrix shown below aligns each activity in this module to standards for teaching STEM according to four primary focus areas within each discipline. The four focus areas for science were adapted from the [Next Generation Science Standards](#) (NGSS) middle school disciplinary core ideas. The four focus areas for technology were adapted from the [International Society for Technology in Education](#) (ISTE) Standards for Students. The four focus areas for engineering were adapted from the [National Science Teaching Association \(NSTA\) and NGSS](#) science and engineering practices. The four focus areas for mathematics were adapted from the [Common Core State Standards \(CCSS\) for Math](#) middle school content standards by domain. Find additional matrices in the Appendix: STEM Standards and Practices.

Activity	STEM Disciplines														
	Science				Technology				Engineering				Math		
	NGSS Disciplinary Core Ideas				ISTE Standards for Students				NSTA and NGSS Practices				CCSS Content Standards by Domain		
	Physical Sciences	Life Sciences	Earth and Space Sciences	Engineering, Technology, and the Application of Sciences	Knowledge Constructor	Innovative Designer	Computational Thinker	Global Collaborator	Ask Questions and Define Problems	Develop and Use Models	Plan and Carry Out Investigations	Construct Explanations and Design Solutions	Ratios and Proportional Relationships	The Number System	Statistics and Probability
Analyze the Geometry of a Spacecraft						✓							✓		✓
Design a Crew Module			✓		✓		✓	✓	✓	✓	✓				
Model a Spacecraft Docking System	✓					✓	✓		✓			✓	✓		✓
Build a Heat Shield	✓			✓	✓		✓	✓	✓	✓					

## Engineering Design Process

The engineering design process (EDP) is crucial to mission success at NASA. The EDP is an iterative process involving a series of steps that engineers use to guide them as they solve problems. The steps outlined below can be used by student teams to solve the challenges in this activity guide. Learn more about the EDP with NASA's Educator Professional Development Collaborative at <https://www.txstate-epdc.net/models-of-the-engineering-design-process/>.

1. ASK: Identify the problem, requirements that must be met, and the constraints that must be considered.
2. IMAGINE: Brainstorm solutions and research what others have done in the past.
3. PLAN: Select and sketch a design.
4. CREATE: Build a model or a prototype.
5. TEST: Evaluate solutions by testing and collecting data.
6. IMPROVE: Refine the design.
7. SHARE: Communicate and discuss the process and solutions as a group.

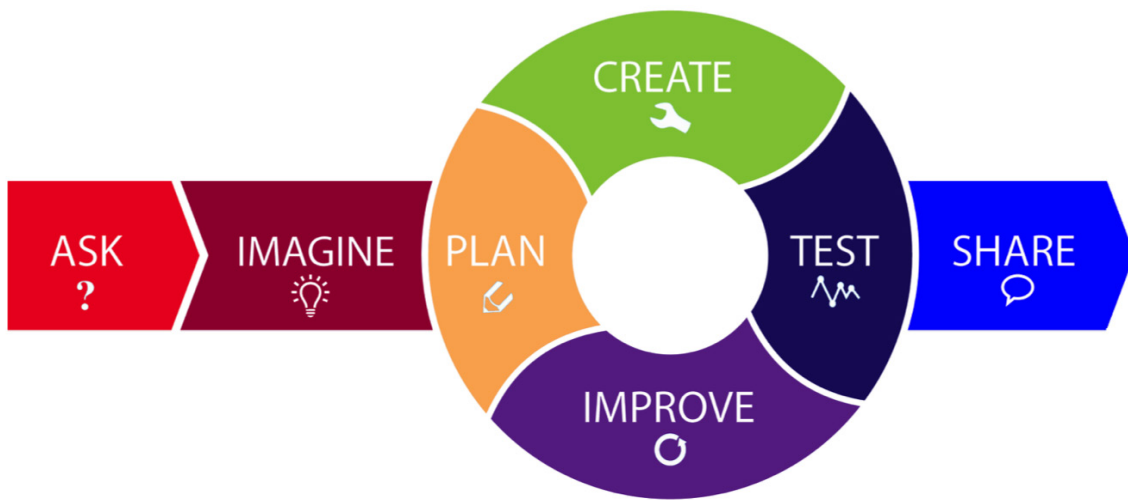

Tip: In order to manage the dynamics within each team, it may be helpful to assign each student within the group a specific task, such as materials manager, design engineer, fabrication engineer, communications specialist, or team manager. Having each team member in charge of a different element of the task may reduce internal conflict within teams.

## Introduction and Background

Orion is the NASA spacecraft that will carry astronauts to the Moon on the upcoming Artemis missions. It will launch on NASA's new heavy-lift rocket, the Space Launch System (SLS). Orion will serve as the vehicle that will take astronauts to space, provide emergency abort capability, sustain the crew during their missions, and provide safe reentry velocities from deep space as astronauts return to Earth.

To protect astronauts on these long-duration missions and return them safely to Earth, Orion engineers have woven innovative technology, advanced systems, and state-of-the-art thermal protection into the fabric of the spacecraft. The team behind Orion has built upon the past 50 years of space exploration experience in human space flight, launch operations, robotic precursor missions, in-space construction, and mission management.



Recovery of the Orion test module in the Pacific Ocean. (NASA)

## Artemis Missions

Artemis was the twin sister of Apollo and the goddess of the Moon in Greek mythology; she was also referred to as the “torch bringer.” Artemis now personifies NASA’s path to the Moon. As part of the broader Moon to Mars exploration objective, this program name is the umbrella under which NASA’s lunar plans will be branded. By 2024, the third Artemis mission will land the first woman and the next man on the Moon.

### Artemis I

Artemis I is the first integrated flight test of NASA’s Orion spacecraft and the SLS rocket. This uncrewed mission will be the first in a planned series of exploration missions in the vicinity of the Moon and will travel 64,000 km (40,000 miles) beyond the lunar surface. This first exploration mission will allow NASA



Artemis Mission Logo.

## Crew Transportation With Orion

to use the area of space near the Moon as a proving ground to test technologies farther from Earth and demonstrate that Orion can get to a stable orbit in the lunar vicinity to support sending humans to deep space.

### Artemis II

The second flight will take crew on a slightly different trajectory and test Orion's critical systems with humans on board. The SLS will evolve from an initial configuration capable of sending a minimum of 70 metric tons to the Moon to a new and more powerful configuration that can deliver at least 105 metric tons. Future exploration missions will include visits to the Gateway, a space habitat in orbit around the Moon. NASA and its partners will use the Gateway to create a permanent presence in cislunar space that will drive activity with commercial and international partners, help explore the Moon and its resources, and leverage that experience toward human missions to Mars.

### Artemis III

The third flight will deliver the first crew to the surface of the Moon since 1972. This flight will take the crew to the Moon's south pole via a human landing system departing from the Gateway in lunar orbit.

## Orion: Learning From the Past With Apollo

Orion will use an improved, larger, blunt-body module, much like the shape of the Apollo capsule. With a diameter of 16.5 ft (5 m), the Orion crew module will have 1.5 times the habitable volume of the Apollo capsule. With a habitable volume of approximately 217.9 ft<sup>3</sup> (6.17 m<sup>3</sup>), the Apollo could carry a three-member crew. The Orion crew module has a habitable volume of 316 ft<sup>3</sup> (9 m<sup>3</sup>) and will be able to carry a four-member crew. During Orion's planning process, NASA studied several different kinds of entry vehicles and rockets. Although Apollo-era researchers were consulted, NASA did not set out to make the Orion spacecraft identical to the Apollo spacecraft. Ultimately, the chosen module design met NASA's mission requirements while being the safest and most effective.

### Resource

Orion Fact Sheet: [https://www.nasa.gov/sites/default/files/fs-2014-08-004-jsc-orion\\_quickfacts-web.pdf](https://www.nasa.gov/sites/default/files/fs-2014-08-004-jsc-orion_quickfacts-web.pdf)

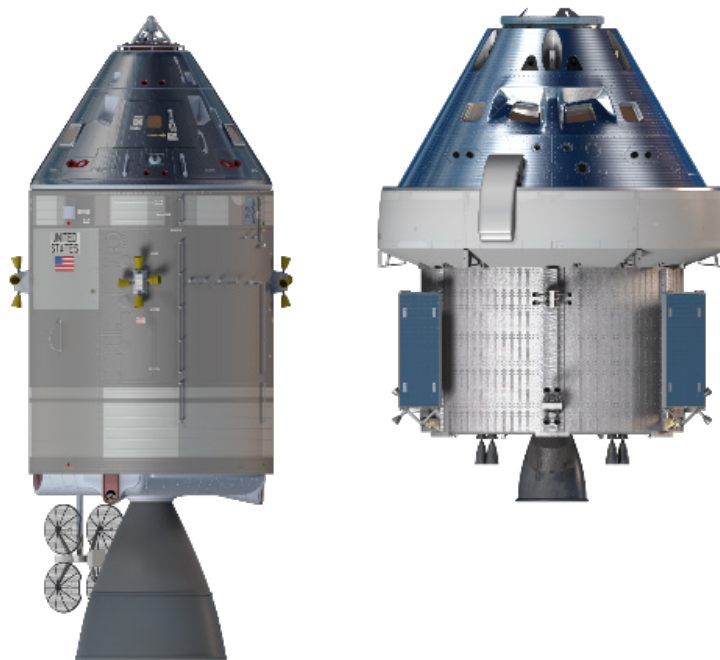

Apollo capsule (left) and Orion module (right).

# Orion: Expanded View



## Launch Abort System

The Launch Abort System, positioned on a tower atop the crew module, can activate within milliseconds to propel the vehicle to safety and position the crew module for a safe landing. This was demonstrated during the [Ascent Abort-2 \(AA-2\) Flight Test](#).

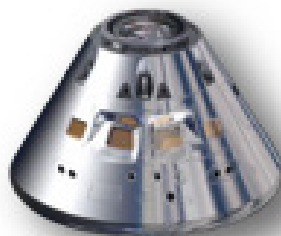

## Crew Module

The crew module is capable of transporting four crewmembers beyond the Moon, providing a safe habitat from launch through landing and recovery. Inside the familiar deep-space capsule shape are advances in life support, avionics, power systems, and advanced manufacturing techniques.



## Service Module

The service module provides support to the crew module from launch through separation prior to reentry. It provides in-space propulsion for orbital transfer, power and thermal control, attitude control, and high-altitude ascent aborts. While mated with the crew module, it also provides water and air to support the crew.



## The Process of Creating the Orion Crew Module

The Orion crew module, or pressure vessel, is the primary structure that creates the atmosphere astronauts will breathe and work in while in the vacuum of deep space. Orion is specifically designed to withstand the harsh and demanding environment of deep space travel while keeping the crew safe and comfortable.

The main structure of the pressure vessel is composed of seven large, machined aluminum alloy pieces that are welded together to produce an airtight module that is strong yet lightweight. The module is welded together by a state-of-the-art process called friction stir welding. Friction stir welding produces an extremely strong bond of the two aluminum components with a uniform welded joint.

### How Does Friction Stir Welding Work?

A pin tool is rotated at between 180 to 300 revolutions (circular movements) per minute, depending on the thickness of the material. The pin tip of the dowel is forced into the material under pressure. The pin continues rotating and, as it rotates, friction heats the surrounding material and rapidly produces a softened area around the pin, which can be described as plasticized. This process under pressure creates a bond between the two pieces of material without melting the material. This results in a uniform bond between the two pieces of metal that creates a strong joint and increases safety. Using a process called nondestructive ultrasonic inspection, scientists can then evaluate the joint weld to make sure the weld is stable and capable of withstanding the dynamic forces of launch.

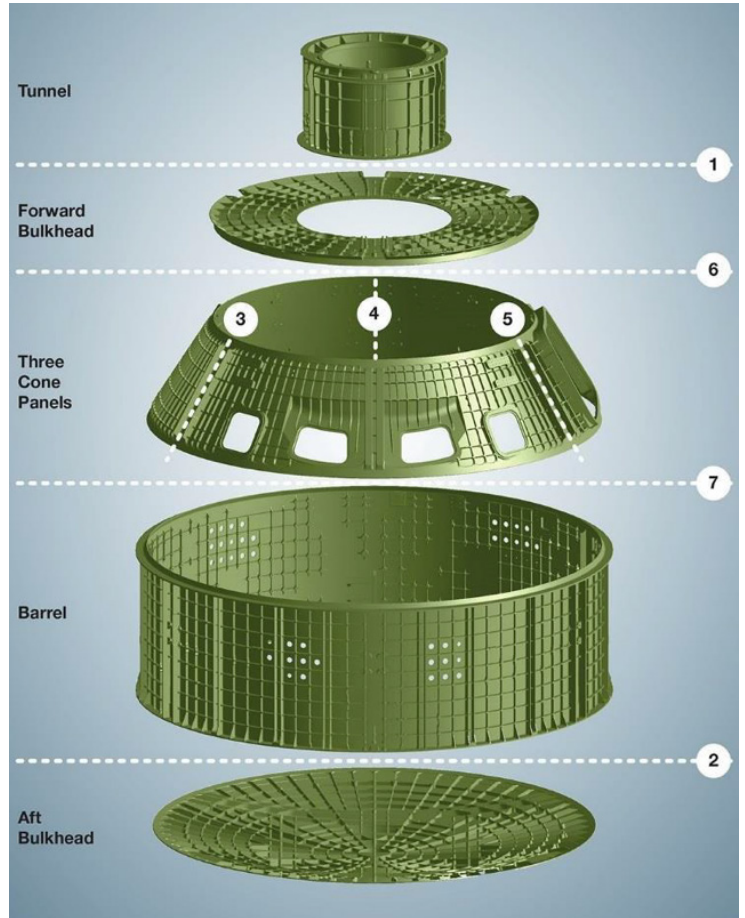

Diagram showing the seven components of Orion's primary structure and the order in which they are welded together. (NASA)



Orion's bulkhead and nose cone are joined using friction stir welding at NASA's Michoud Assembly Facility. (NASA)

## Orion Docking Capabilities

Even before the first successful space flight, scientists and engineers envisioned spacecraft docking with space stations and other spacecraft to transfer people and supplies. This was first successfully accomplished in 1966, when American astronaut Neil Armstrong piloted NASA's Gemini VIII spacecraft and docked with an Agena target vehicle. This important test showed that two spacecraft could be joined in space, an important step in the race to put a man on the Moon. (Three years later, Neil Armstrong would be that man!)

Early docking systems had limitations, however. They used a system called probe and drogue. One spacecraft had a long rod (the probe), which would be inserted into a funnel (the drogue) on the target spacecraft. This system worked fine for two spacecraft designed to go together—one with a probe and the other with a drogue. However, if both spacecraft had probes, or both had drogues, they would not be able to dock with each other.

Engineers then designed docking systems that were androgynous, meaning that the two identical docking systems could dock with each other. This made spacecraft, resupply vehicles, and space station docking more versatile. But with different countries' space agencies and private companies using different systems, many craft were still unable to dock with each other without the addition of heavy and expensive adapters.

Increasing cooperation among international space agencies and private companies led to the design of the International Docking System Standard (IDSS). Any craft that uses this new system will be able to dock with any other craft with the same system. The two craft will also be able to share air, water, power, communications, and even fuel. NASA has adopted this system, and its IDSS-compatible docking adapters are called the NASA Docking System (NDS). Two NDS adapters have already been installed on the International Space Station.

NASA's newest spacecraft, Orion, incorporates an NDS as part of its design. Orion will have to dock with many different types of spacecraft in order to fulfill its many roles, such as docking with the planned Gateway platform in orbit around the Moon, docking with landers and other support craft, and even docking with a larger habitat craft for a mission to Mars.

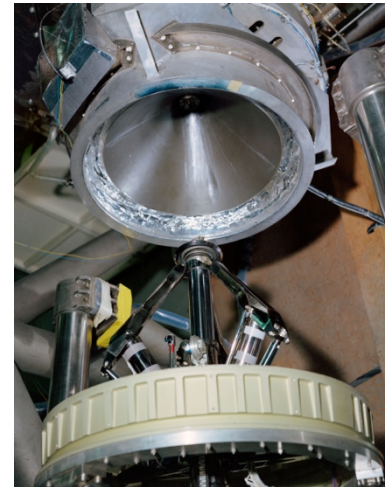

Docking system with probe (bottom) and cone-shaped drogue (top).  
(NASA)

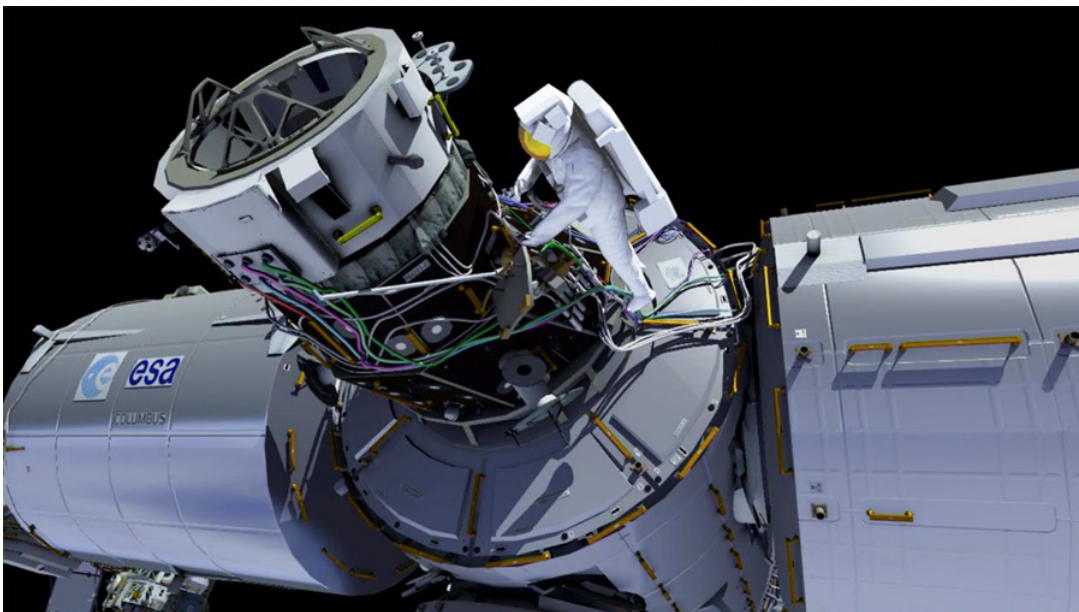

This computer rendering depicts an astronaut from the International Space Station performing a spacewalk to install the International Docking Adapter. ([NASA Johnson YouTube](#))

# Activity One: Analyze the Geometry of a Spacecraft

## Educator Notes

### Challenge

Students (individually or in small groups) will use geometry to find the area of the horizontal and vertical cross sections of a crew module.

### Suggested Time

45 to 60 minutes

### Learning Objectives

Students will

- Decompose a complex geometric shape into more basic geometric shapes.
- Approximate the total area of a complex geometric shape by using measurements and geometric formulas to find the summation of the areas of the more basic geometric shapes.
- Learn about careers at NASA.

### Curriculum Connection

Science and Engineering (NGSS)	
<p><i>Crosscutting Concepts</i></p> <ul style="list-style-type: none"> <li>• Interdependence of Science, Engineering, and Technology: Engineering advances have led to important discoveries in virtually every field of science, and scientific discoveries have led to the development of entire industries and engineered systems.</li> </ul> <p><i>Science and Engineering Practices</i></p> <ul style="list-style-type: none"> <li>• Analyzing and Interpreting Data: Scientific investigations produce data that must be analyzed in order to derive meaning. Because data patterns and trends are not always obvious, scientists use a range of tools—including tabulation, graphical interpretation, visualization, and statistical analysis—to identify the significant features and patterns in the data. Scientists identify sources of error in the investigations and calculate the degree of certainty in the results. Modern technology makes the collection of large data sets much easier, providing secondary sources for analysis.</li> </ul>	<p><i>Science and Engineering Practices (continued)</i></p> <ul style="list-style-type: none"> <li>• Using Mathematics and Computational Thinking: In both science and engineering, mathematics and computation are fundamental tools for representing physical variables and their relationships. They are used for a range of tasks such as constructing simulations; statistically analyzing data; and recognizing, expressing, and applying quantitative relationships.</li> </ul>
Technology (ISTE)	
<p><i>Standards for Students</i></p> <ul style="list-style-type: none"> <li>• Computational Thinker: Students develop and employ strategies for understanding and solving problems in ways that leverage the power of technological methods to develop and test solutions.                             <ul style="list-style-type: none"> <li>– 5c: Students break problems into component parts, extract key information, and develop descriptive models to understand complex systems or facilitate problem solving.</li> </ul> </li> </ul>	
Mathematics (CCSS)	
<p><i>Content Standards by Domain</i></p> <ul style="list-style-type: none"> <li>• CCSS.MATH.CONTENT.6.NS.B.3: Fluently add, subtract, multiply, and divide multidigit decimals using the standard algorithm for each operation.</li> <li>• CCSS.MATH.CONTENT.6.G.A.1: Find the area of right triangles, other triangles, special quadrilaterals, and polygons by composing into rectangles or decomposing into triangles and other shapes; apply these techniques in the context of solving real-world and mathematical problems.</li> <li>• CCSS.MATH.CONTENT.7.NS.A.3: Solve real-world and mathematical problems involving the four operations with rational numbers.</li> <li>• CCSS.MATH.CONTENT.7.G.A.3: Describe the two-dimensional figures that result from slicing three-dimensional figures, as in plane sections of right rectangular prisms and right rectangular pyramids.</li> </ul>	<p><i>Content Standards by Domain (continued)</i></p> <ul style="list-style-type: none"> <li>• CCSS.MATH.CONTENT.7.G.B.6: Solve real-world and mathematical problems involving area, volume, and surface area of two- and three-dimensional objects composed of triangles, quadrilaterals, polygons, cubes, and right prisms.</li> <li>• CCSS.MATH.CONTENT.8.G.C.9: Know the formulas for the volumes of cones, cylinders, and spheres and use them to solve real-world and mathematical problems.</li> </ul> <p><i>Mathematical Practices:</i></p> <ul style="list-style-type: none"> <li>• CCSS.MATH.PRACTICE.MP2: Reason abstractly and quantitatively.</li> <li>• CCSS.MATH.PRACTICE.MP4: Model with mathematics.</li> <li>• CCSS.MATH.PRACTICE.MP5: Use appropriate tools strategically.</li> <li>• CCSS.MATH.PRACTICE.MP6: Attend to precision.</li> </ul>

### Preparation Time

15 minutes

- Read the Introduction and Background, Educator Notes, and Student Handout to become familiar with the activity.
- Determine if students will be working independently or in small groups.
- Gather and prepare all supplies listed on the materials list.
- If presenting videos or web-based resources, test the links and the classroom technology ahead of time.



## Materials

- Copies of Student Handout and blank paper
- Metric rulers with straight edge
- Colored pencils or thin markers
- Grid paper (optional)

## Introduce the Challenge

- Show students the Orion: Expanded View diagram and explain the purpose of the crew module.
- Define **vertical and horizontal cross sections** and ask students to sketch what they think the vertical and horizontal cross sections of the crew module might look like.
- Show students the diagram that depicts the seven structural components of the Orion crew module. Discuss how NASA uses friction stir welding to assemble this complex geometric shape from multiple components composed of simple shapes.
- Explain how complex geometric shapes can be decomposed or broken into multiple simple shapes. Identify examples in the classroom.
- Discuss how to approximate the total area of a complex shape by finding the sum of the areas of each of the simple shapes.
- Review the mathematical formulas for finding the area of basic geometric shapes.
- Distribute the Student Handout and explain the challenge.

## Facilitate the Challenge

### Ask and Imagine

- Provide examples of shapes in the classroom that are symmetric and demonstrate how symmetry can help in decomposing a complex shape.
- Discuss different approaches for finding area of curved surfaces in a complex shape. One option is for students to trace the shape onto grid paper to approximate the area. Ask how the size of the squares on the grid paper impacts the estimation.
- Remind students that if the shape is already simple, it does not need to be decomposed.

### Create

- Students will work individually or in small groups to find the area of the largest vertical and horizontal cross sections of a crew module. Students will record their work on the tables provided.
- Encourage students to use different-colored pencils or highlighters for each geometric shape to show how they are decomposing the figure into smaller parts. For example, using the largest vertical cross section diagram of the crew module, students will likely see the top part of the figure as a trapezoid. The next area is rectangular, but students may select different segments for their length estimate. The bottom of the diagram might be decomposed into a triangle.
- The largest horizontal cross section will be a circle, so students will not need to further decompose this shape.

### Share

- Once the exercise is completed, have students form pairs or small groups to discuss and evaluate the various approaches taken to decompose the crew module into smaller shapes, and how symmetry was used in their approaches.
- Have students identify the types of geometric shapes that were found within the crew module.

## Share With Students



### Brain Booster

Starting with the formation of NASA in October 1958, intense efforts were undertaken to create a manned space vehicle that could fly a human in orbit around the Earth. The plans for this vehicle were based on the blunt reentry body proposed earlier by Harvey Allen and Max Faget. These efforts would eventually result in the Mercury spacecraft.

Learn more:

<https://history.nasa.gov/SP-350/ch-2-2.html>



### On Location

Mathematics and physics models need to be expressed and translated in a language computers can understand and work with, which often requires thousands of lines of computer code. NASA Ames Research Center in Mountain View, California, provides supercomputing capabilities for more than 1,500 users across the United States who rely on high-end computing to help them visualize and solve mathematical problems every day.

Learn more:

<https://www.nasa.gov/centers/ames/areas-of-ames-ingenuity-supercomputing>

## Crew Transportation With Orion

- Discuss why different approaches resulted in different areas.
- Give students an opportunity to see one solution for the decomposition of the crew module.
- Share photos of horizontal and vertical cross sections showing astronauts inside the crew modules.

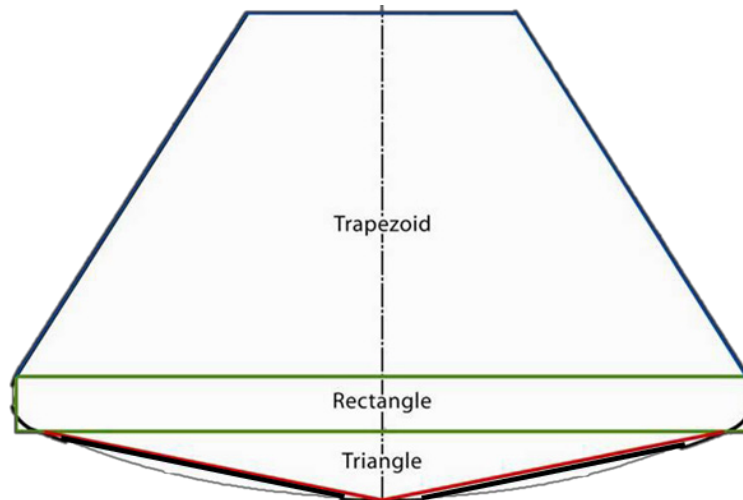

One solution for the decomposition of the crew module (vertical cross section).



(a)



(b)

Four astronauts in the Orion module. (a) Horizontal cross section (birds-eye view). (b) Vertical cross section (side view). (NASA)

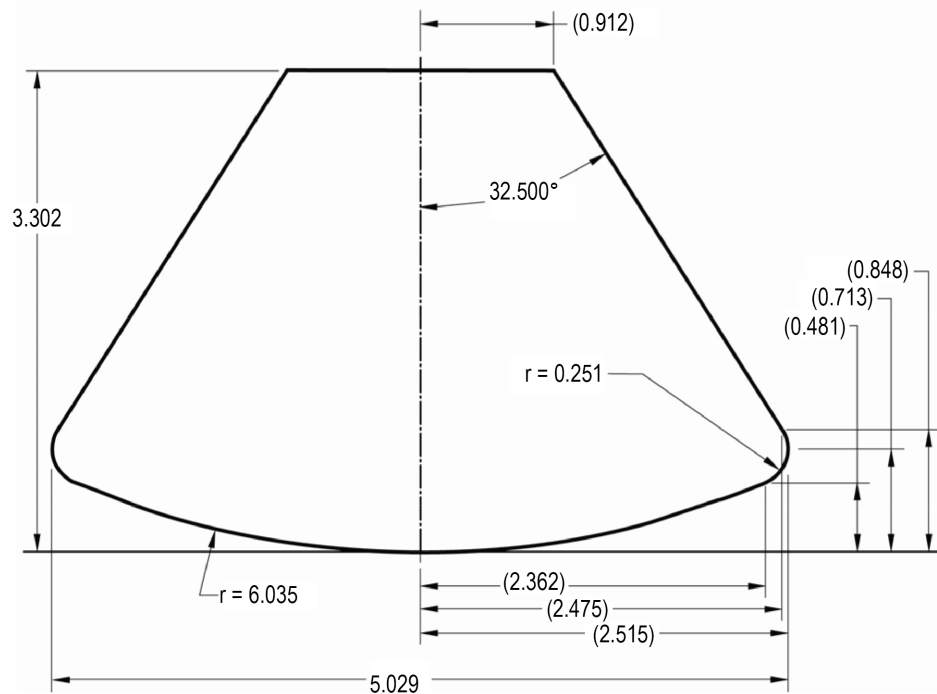

Largest vertical cross section of the Orion crew module. All measurements in meters unless otherwise noted.

### Extensions

- Use the measurements in the diagram above to find the scale factor of the diagram compared to the actual life-size crew module.
- Compare the size of the actual crew module to the size of your classroom.
- Identify the three-dimensional shapes that make up the actual crew module (e.g., truncated cone sitting on a disc or cylinder with an inverted dome). Refer to the diagram in the Introduction and Background section that shows the seven components of Orion's primary structure.

### Reference

Modified from Exploring Space through Algebra. [https://er.jsc.nasa.gov/seh/264011main\\_Algebra\\_Stu\\_Orion.pdf](https://er.jsc.nasa.gov/seh/264011main_Algebra_Stu_Orion.pdf)

### Additional Resources

- Video: Final Friction Stir Weld Completed on Orion. <https://www.youtube.com/watch?v=m3pOe8gk0Jo>
- Video: NASA Now: Engineering: Friction Stir Welding (features welding engineer at Marshall Space Flight Center). <https://www.youtube.com/watch?v=XM825iLaPvU>
- Digital Badging: Online NASA STEM Learning. <https://www.txstate-epdc.net/digital-badging/>

# Activity One: Analyze the Geometry of a Spacecraft

## Student Handout

### Your Challenge

Use geometry to find the area of the vertical and horizontal cross sections of a crew module.

### Ask and Imagine

- How does decomposing a complex geometric shape help you find the area?
- How does symmetry aid in decomposing a complex geometric shape into simple shapes?
- When decomposing the crew module into multiple simple shapes, you will eventually have curved surfaces that do not fit with the shapes you draw. What can you do to minimize this and keep your calculation of the crew module's area as accurate as possible?

### Create

1. Using a different colored pencil for each geometric shape, begin decomposing the vertical cross section of the crew module on the following page into individual simple shapes. Create as many shapes as necessary to fill in as much of the crew module cross section as possible.
2. Measure and record the dimensions of each shape in the accompanying chart.
3. Calculate the area of each shape you created and record it on the chart.
4. Find the sum of all your area measurements for the module cross section to determine its total area.
5. Find the area of the horizontal cross section of the crew module.

### Share

When you finish finding the areas, answer each of the following questions with a partner or small group:

- What steps did you take to decompose the crew module into smaller shapes? How was symmetry used?
- What types of geometric shapes were found within the crew module?
- Did each person or group calculate the same area? Why or why not?

### Fun Fact

The Orion heat shield is composed of a titanium skeleton and carbon fiber skin that gives the crew module its rounded shape on the bottom. The outermost layer chars away during the intense heat of reentry and is removed and replaced by 180 individual blocks for each launch.

Learn more:

<https://www.nasa.gov/feature/nasa-applies-insights-for-manufacturing-of-orion-spacecraft-heat-shield>

### Career Corner

Katherine Johnson is a retired mathematician who worked for NASA from 1953 until 1986. Johnson and other women were hired as “human computers” to calculate the trajectory, or flight path, for the rocket that would put the first American in space in 1961. NASA is always looking for the brightest mathematicians, and there are many other rewarding careers that involve numbers, problem solving, and mathematical modeling.

Learn more:

<https://www.nasa.gov/audience/forstudents/5-8/features/nasa-knows/who-is-katherine-johnson-5-8>

**Vertical Cross Section**

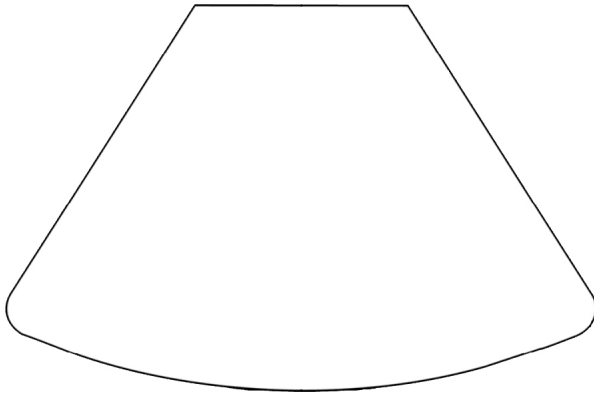

Vertical cross section (side view) of a crew module.

Shape name	Dimensions, cm (length, width, height, diameter, etc.)	Formula for area of shape	Area of shape, cm <sup>2</sup>
<b>Total area, cm<sup>2</sup></b>			_____

**Horizontal Cross Section**

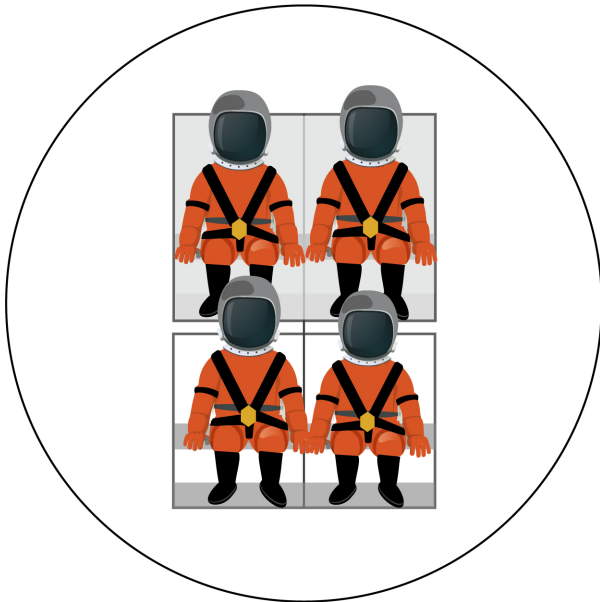

Horizontal cross section (bird's-eye view) of a crew module.

Shape name	Dimensions, cm (length, width, height, diameter, etc.)	Formula for area of shape	Area of shape, cm <sup>2</sup>
<b>Total area, cm<sup>2</sup></b>			_____

## Activity Two: Design a Crew Module

### Educator Notes

#### Challenge

Students will work together as a team to design and build a crew module model that will secure two 2-cm-sized astronaut figures during a drop test.

#### Suggested Time

60 minutes

#### Learning Objectives

Students will

- Apply the steps of the engineering design process to successfully complete a team challenge.
- Design, build, and test their crew module.
- Collect data after each drop test for analysis and comparison with other groups.
- Improve their model based upon the results of the drop tests.

#### Curriculum Connection

Science and Engineering (NGSS)	
<p><i>Disciplinary Core Ideas</i></p> <ul style="list-style-type: none"> <li>• MS-ETS1-1 Engineering Design: Define the criteria and constraints of a design problem with sufficient precision to ensure a successful solution, taking into account relevant scientific principles and potential impacts on people and the natural environment that may limit possible solutions.</li> <li>• MS-ETS1-3 Engineering Design: Analyze data from tests to determine similarities and differences among several design solutions to identify the best characteristics of each that can be combined into a new solution to better meet the criteria for success.</li> <li>• MS-ETS1-4 Engineering Design: Develop a model to generate data for iterative testing and modification of a proposed object, tool, or process such that an optimal design can be achieved.</li> </ul> <p><i>Crosscutting Concepts</i></p> <ul style="list-style-type: none"> <li>• Systems and System Models: Models can be used to represent systems and their interactions—such as inputs, processes, and outputs—and energy and matter flows within systems.</li> <li>• Structure and Function: The way an object is shaped or structured determines many of its properties and functions.</li> </ul>	<p><i>Crosscutting Concepts (continued)</i></p> <ul style="list-style-type: none"> <li>• Interdependence of Science, Engineering, and Technology: Engineering advances have led to important discoveries in virtually every field of science, and scientific discoveries have led to the development of entire industries and engineered systems.</li> </ul> <p><i>Science and Engineering Practices</i></p> <ul style="list-style-type: none"> <li>• Asking Questions and Defining Problems: A practice of science is to ask and refine questions that lead to descriptions and explanations of how the natural and designed world works and which can be empirically tested.</li> <li>• Developing and Using Models: A practice of both science and engineering is to use and construct models as helpful tools for representing ideas and explanations. These tools include diagrams, drawings, physical replicas, mathematical representations, analogies, and computer simulations.</li> <li>• Planning and Carrying Out Investigations: Scientists and engineers plan and carry out investigations in the field or laboratory, working collaboratively as well as individually. Their investigations are systematic and require clarifying what counts as data and identifying variables or parameters.</li> <li>• Constructing Explanations and Designing Solutions: The products of science are explanations and the products of engineering are solutions.</li> </ul>
Technology (ISTE)	
<p><i>Standards for Students</i></p> <ul style="list-style-type: none"> <li>• Innovative Designer: Students use a variety of technologies within a design process to identify and solve problems by creating new, useful, or imaginative solutions.                             <ul style="list-style-type: none"> <li>— 4a: Students know and use a deliberate design process for generating ideas, testing theories, creating innovative artifacts, or solving authentic problems.</li> </ul> </li> </ul>	<p><i>Standards for Students (continued)</i></p> <ul style="list-style-type: none"> <li>— 4c: Students develop, test, and refine prototypes as part of a cyclical design process.</li> <li>— 4d: Students exhibit a tolerance for ambiguity, perseverance, and the capacity to work with open-ended problems.</li> </ul>
Mathematics (CCSS)	
<p><i>Mathematical Practices</i></p> <ul style="list-style-type: none"> <li>• CCSS.MATH.PRACTICE.MP1: Make sense of problems and persevere in solving them.</li> </ul>	<p><i>Mathematical Practices (continued)</i></p> <ul style="list-style-type: none"> <li>• CCSS.MATH.PRACTICE.MP3: Construct viable arguments and critique the reasoning of others.</li> </ul>

#### Preparation Time

15 minutes

- Read the Introduction and Background, Educator Notes, and Student Handout to become familiar with the activity.
- Gather and prepare all supplies listed on the materials list.
- Determine the size constraint for the crew module in advance of the lesson. Select a mailing tube, oatmeal canister, or coffee can.
- If presenting videos or web-based resources, test the links and the classroom technology ahead of time.



## Materials

- General building supplies:
  - Paper or foam cups
  - Paper or foam plates
  - Index cards
  - Aluminum foil or plastic wrap
- Mailing tube, oatmeal canister, or small coffee can (used as a size constraint)
- 2-cm plastic figurines, 2 per team (e.g., LEGO® minifigures)
- Tape
- Scissors
- Metric scale
- Meterstick
- Paper and pencil for brainstorming
- Copies of Student Handout and blank paper

## Introduce the Challenge

- Provide context for this activity using the Introduction and Background information in this guide. Show students the diagram of a crew module (Orion: Expanded View) and explain its purpose. Discuss the importance of testing any spacecraft, but especially a crew vehicle. Ask students why it is important to test their own designs.
- Explain the role of engineers in designing technology to solve problems. Share the NASA for Kids video [Intro to Engineering](#) and introduce the engineering design process.
- Discuss the importance of mass in space travel. The more massive the crew module, the more expensive it would be to build and to launch. Students should keep this in mind during construction. Emphasize that NASA is looking for a lightweight but strong crew module.
- Divide the class into teams (three to five students) and distribute the Student Handout to each team. Explain the details of the challenge, including the design constraints and your expectations for teamwork and classroom management.

## Design Constraints

1. The crew module must safely carry two astronauts. Each team must design and build secure seats for the astronauts, without gluing or taping the astronauts in place. The astronauts must stay in their seats during each drop test.
2. The crew module must fit into the size constraint container provided. This item is simply a size constraint; the crew module will **not** be dropped while inside the container.
3. The crew module must have at least one hatch that opens and closes easily. The hatch must remain closed during all drop tests.
4. The crew module design should consider mass as well as strength. Mass is important in space travel. The more massive the crew module, the more expensive it would be to build and, ultimately, to launch. Keep that in mind during construction. NASA is looking for a lightweight but strong crew module.

## Facilitate the Challenge

### Ask, Imagine, and Plan

Engage students with the following discussion questions:

- What parts of a spacecraft are essential for carrying astronauts?
- What elements are needed for crew safety?

## Share With Students



### Brain Booster

NASA material engineers select and test the composite materials, paints, coatings, foams, and other technologies to build spacecraft. The goal of this career is to stretch materials to their limits and even use them in ways they were not originally designed for. These materials will ultimately build the next generation of vehicles to take explorers to the Moon and beyond. Material engineer is a career on the cutting edge of technology.

Learn more:

[https://www.youtube.com/watch?time\\_continue=28&v=61wd30JO7fk](https://www.youtube.com/watch?time_continue=28&v=61wd30JO7fk)



### On Location

NASA Langley Research Center uses mannequins, or “test dummies,” during impact tests to study the effect splashdowns or rough landings can have on the human body. The test dummies are outfitted with a variety of sensors that collect data to help researchers understand how an actual human body would experience the crash simulation. Collecting the data helps NASA improve aviation policies, design suit and helmet adjustments, and make spacecraft and aircraft improvements to ensure mission success for both commercial flight passengers and astronauts.

Learn more:

<https://www.youtube.com/watch?v=DE2wxVrrQ4w>

## Crew Transportation With Orion

- What types of safety devices protect passengers in vehicles on or near Earth? Will these same features work in space?
- What types of materials will protect the astronauts?
- How can you reduce the force of impact on the crew module and astronauts?
- What design features will allow a hatch that can open and close after splashdown?

### Create

- Each team will build their crew module using only the materials supplied.

### Test and Improve

- Each team will conduct two drop tests from a height of 1 to 2 m. Students can also simply hold the crew module over their heads and drop it, but the drop height must be consistent to control testing variables. Demonstrate the proper method for conducting a drop test.
- After each drop test, students will improve their crew module based on the results of the experiment and their understanding of scientific concepts, including transfer of energy, forces, and motion.

### Share

Engage students with the following discussion questions:

- What was the greatest challenge for your team today?
- Why was it important that the hatch stay closed during the drop tests?
- What processes will your crew module undergo that make it important for the astronauts to stay secured in their seats?
- How does your experiment relate to Newton's laws?

### Extension

- Add a cost constraint to the challenge and create a budget for students to "purchase" materials. Assign cost to all materials based on mass, area, or type of material.

### Reference

Modified from Design a Crew Exploration Vehicle. [https://www.nasa.gov/pdf/630754main\\_NASAsBESTActivityGuide6-8.pdf](https://www.nasa.gov/pdf/630754main_NASAsBESTActivityGuide6-8.pdf)

### Additional Resources

- Website: Learn More About the Orion Spacecraft. <https://www.nasa.gov/exploration/systems/orion/index.html>
- Video: NASA Edge—Orion Flight Test Article. <https://www.youtube.com/watch?v=uiocMUA-zbU>
- Video: Career Connection—NASA Orion Engineer. <https://www.youtube.com/watch?v=nNzskBHGqYo>
- Extended Engineering Design Challenge Educator Guide. <https://www.nasa.gov/glenn-edcs-spacecraft-safety>
- Digital Badging: Online NASA STEM Learning. <https://www.txstate-epdc.net/digital-badging/>



Orion water landing test. (NASA)



## Activity Two: Design a Crew Module

### Student Handout

#### Your Challenge

Design and build a crew module model that will secure two 2-cm-sized astronaut figures during a drop test.

#### Design Constraints

1. The crew module must safely carry two astronauts. You must design and build a secure seat for the astronauts, without gluing or taping them in place. The astronauts should stay in their seats during each drop test.
2. The crew module must fit into the container your teacher has provided. This item is simply for a size constraint. The crew module will **not** be dropped while inside the container.
3. The crew module must have one hatch that opens and closes easily. The hatch should remain shut during all drop tests.
4. Your crew module design should consider mass as well as strength. Mass is important in space travel. The more massive the crew module, the more expensive it would be to build and, ultimately, to launch. Keep that in mind during construction. NASA is looking for a lightweight but strong crew module.

#### Ask and Imagine

Discuss ways to safely secure two astronauts inside of the crew module.

- What types of materials will protect the astronauts?
- How can you reduce the force of impact on the crew module and astronauts?
- What essential elements are needed for crew safety?

#### Plan

Draw your crew module design on the blank paper your teacher has provided. Be sure to label your design with the materials you will be using.

#### Create

Your team will build a crew module that meets all design constraints using only the materials supplied by your teacher.

#### Test and Improve

- Your team will conduct two drop tests from a height of 1 m.
- After each series of drop tests, improve the crew module based on the results and test again.
- Once a drop is successful from 1 m, your team will then drop the crew module from at least 2 m high.

#### Share

- Discuss the results of your experiment and share details with the class.
- What techniques did you use to reduce mass of your crew module?
- What improvements did you make to your crew module based on your first test?
- Which team had the most successful and least massive crew module? Based on their success, what changes would you make to your crew module?



#### Fun Fact

Did you know that temper foam engineered for NASA has been used to pad racecars and the helmets of football players? This foam padding was originally developed in 1966 to absorb shock while providing comfort and protection in NASA airplane seats. Even today, temper foam has found its way into the insoles of shoes so people around the globe need not sacrifice style for comfort!

Learn more:

<https://spinoff.nasa.gov/database/?k=temper%20foam>



#### Career Corner

Interested in becoming an astronaut? You can join the astronaut corps as either a pilot or mission specialist. Most astronauts have a STEM degree and have had careers as scientists, engineers, or even medical doctors. Some astronauts have also been teachers!

Learn more:

<https://www.nasa.gov/astronauts>

# Activity Three: Model a Spacecraft Docking System

## Educator Notes

### Challenge

Students will work together as a team to construct and test a model of a target docking system and crew module.

### Suggested Time

60 minutes

### Learning Objectives

Students will

- Make metric length measurements with 0.1-cm accuracy.
- Use given ratios to calculate dimensions of a scale model.
- Demonstrate their knowledge of traveling through and rotating about the three axes of movement.
- Demonstrate teamwork and communication skills to perform a task.

### Curriculum Connection

Science and Engineering (NGSS)	
<p><i>Disciplinary Core Ideas</i></p> <ul style="list-style-type: none"> <li>• MS-PS2-2 Motion and Stability: Forces and Interactions: Plan an investigation to provide evidence that the change in an object's motion depends on the sum of the forces on the object and the mass of the object.                             <ul style="list-style-type: none"> <li>– PS2.A: Forces and Motion: The motion of an object is determined by the sum of the forces acting on it; if the total force on the object is not zero, its motion will change. The greater the mass of the object, the greater the force needed to achieve the same change in motion. For any given object, a larger force causes a larger change in motion. All positions of objects and the directions of forces and motions must be described in an arbitrarily chosen reference frame and arbitrarily chosen units of size. In order to share information with other people, these choices must also be shared.</li> </ul> </li> </ul> <p><i>Crosscutting Concepts</i></p> <ul style="list-style-type: none"> <li>• System and System Models: A system is an organized group of related objects or components; models can be used for understanding and predicting the behavior of systems.</li> </ul>	<p><i>Crosscutting Concepts (continued)</i></p> <ul style="list-style-type: none"> <li>• Structure and Function: The way an object is shaped or structured determines many of its properties and functions.</li> </ul> <p><i>Science and Engineering Practices</i></p> <ul style="list-style-type: none"> <li>• Developing and Using Models: A practice of both science and engineering is to use and construct models as helpful tools for representing ideas and explanations. These tools include diagrams, drawings, physical replicas, mathematical representations, analogies, and computer simulations.</li> <li>• Using Mathematics and Computational Thinking: In both science and engineering, mathematics and computation are fundamental tools for representing physical variables and their relationships. They are used for a range of tasks such as constructing simulations; statistically analyzing data; and recognizing, expressing, and applying quantitative relationships.</li> </ul>
Technology (ISTE)	
<p><i>Standards for Students</i></p> <ul style="list-style-type: none"> <li>• Computational Thinker: Students develop and employ strategies for understanding and solving problems in ways that leverage the power of technological methods to develop and test solutions.                             <ul style="list-style-type: none"> <li>– 5c: Students break problems into component parts, extract key information, and develop descriptive models to understand complex systems or facilitate problem solving.</li> </ul> </li> </ul>	<p><i>Standards for Students (continued)</i></p> <ul style="list-style-type: none"> <li>• Global Collaborator: Students use digital tools to broaden their perspectives and enrich their learning by collaborating with others and working effectively in teams locally and globally.                             <ul style="list-style-type: none"> <li>– 7c: Students contribute constructively to project teams, assuming various roles and responsibilities to work effectively toward a common goal.</li> </ul> </li> </ul>
Mathematics (CCSS)	
<p><i>Content Standards by Domain</i></p> <ul style="list-style-type: none"> <li>• CCSS.MATH.CONTENT.6.RP.A.1: Understand the concept of a ratio and use ratio language to describe a ratio relationship between two quantities.</li> <li>• CCSS.MATH.CONTENT.6.NS.B.3: Fluently add, subtract, multiply, and divide multidigit decimals using the standard algorithm for each operation.</li> <li>• CCSS.MATH.CONTENT.7.NS.A.3: Use proportional relationships to solve multistep ratio and percent problems.</li> </ul>	<p><i>Content Standards by Domain (continued)</i></p> <ul style="list-style-type: none"> <li>• CCSS.MATH.CONTENT.7.G.A.1: Solve problems involving scale drawings of geometric figures, including computing actual lengths and areas from a scale drawing and reproducing a scale drawing at a different scale.</li> </ul> <p><i>Mathematical Practices:</i></p> <ul style="list-style-type: none"> <li>• CCSS.MATH.PRACTICE.MP5: Use appropriate tools strategically.</li> <li>• CCSS.MATH.PRACTICE.MP6: Attend to precision</li> </ul>

### Preparation Time

30 minutes

- Read the Introduction and Background, Educator Notes, and Student Handout to become familiar with the activity.
- Gather and prepare all supplies listed on the materials list.
- If presenting videos or web-based resources, test the links and the classroom technology ahead of time.
- Determine if students will be working independently or in small groups to construct the models. Teams of three are recommended for testing the docking system.

## Materials

- Small foam cups (2 per team)
- Bendable plastic straws (6 per team)
- Construction paper
- Pens/pencils
- Tape
- Scissors
- Metric ruler
- String
- Copies of Student Handout and blank paper
- Plastic knife (optional)
- Drafting compass for drawing circles (optional)
- Calculator (optional)
- Blindfolds (optional)

## Introduce the Challenge

- Provide context for this activity using the Introduction and Background information in this guide. Use the Orion: Expanded View image to identify and discuss the three functional components of a crew vehicle:
  - Crew module
  - Service module
  - Launch abort system
- Discuss how the crew module has the capability to couple, or dock, to the pressurized mating adapters of the International Space Station and future deep space spacecraft. The docking port serves as both a parking spot for the vehicle and an entrance to the spacecraft.
- Distribute the Student Handout and explain the challenge. Emphasize the importance of taking careful measurements and making accurate calculations.
- Explain the role of models and simulations in designing technology to solve problems.
- Introduce any new terminology (e.g., docking system, mockup, and scale model).

## Facilitate the Challenge

### Ask and Imagine

Engage students with the following discussion questions:

- Why are astronauts trained on the docking system with computer simulations before they travel into space? (See Additional Resources for a NASA Commercial Crew Program application with a simulated docking component.)
- What safety measures need to be taken into consideration when designing a space docking port?
- Why do NASA engineers build smaller scale models or mockups of NASA spacecraft before committing to an engineering design?

### Create

- Each student or team will construct a model of a target docking system and crew module using the supplies provided.

## Share With Students



### Brain Booster

*Rendezvous* means to meet at a specified time and place. A spacecraft rendezvous is a tricky process. A careful series of maneuvers are required to adjust the horizontal and vertical alignment of each spacecraft. The spacecraft must also maintain a proper speed to safely approach each other for docking.

Learn more:

<https://www.nasa.gov/mission-pages/station/research/news/b4-h-3rd/it-automating-better-space-rendezvous/>



### On Location

The Six-Degree-of-Freedom Dynamic Test System (SDTS) at Johnson Space Center in Houston, Texas, is a motion-based platform capable of six degrees of freedom. The SDTS is primarily used for the simulation and evaluation of the NASA Docking System (NDS) used on Orion to dock with other craft.

Learn more:

<https://er.jsc.nasa.gov/ER5/>

## Crew Transportation With Orion

### Plan, Test, and Improve

- Each team will use their completed crew modules and docking adapters to practice maneuvering and attempt docking.
- Each team will plan maneuvers in order to "dock" the crew module with the target docking system.
- After each attempted maneuver, students will replan or improve their tactics based upon previous experiences.

### Share

Engage students with the following discussion questions:

- What was the greatest challenge for your team today?
- Why was it important for your measurements and calculations to be accurate?
- The diameter of the spacecraft's heat shield is 5.03 m. What is the scale of your model?
- Was your team successful when maneuvering the crew module model into the docking port? Why or why not?
- When spacecraft dock, they do not just share a physical airtight seal. There are also electrical and plumbing connections that can be made. What resources could be shared between two docked spacecraft?
- If you were to participate in this activity again, what would you do differently?

### Extensions

- There are multiple training missions in the Student Handout to differentiate this activity and make it more or less difficult.
- Ask teams to create a model of a new docking system of their own design and demonstrate how it works.

### Additional Resource

- App: Rocket Science—Ride to Station. <https://www.nasa.gov/stem-ed-resources/rocket-science-ride-to-station.html>
- Digital Badging: Online NASA STEM Learning. <https://www.txstate-epdc.net/digital-badging/>

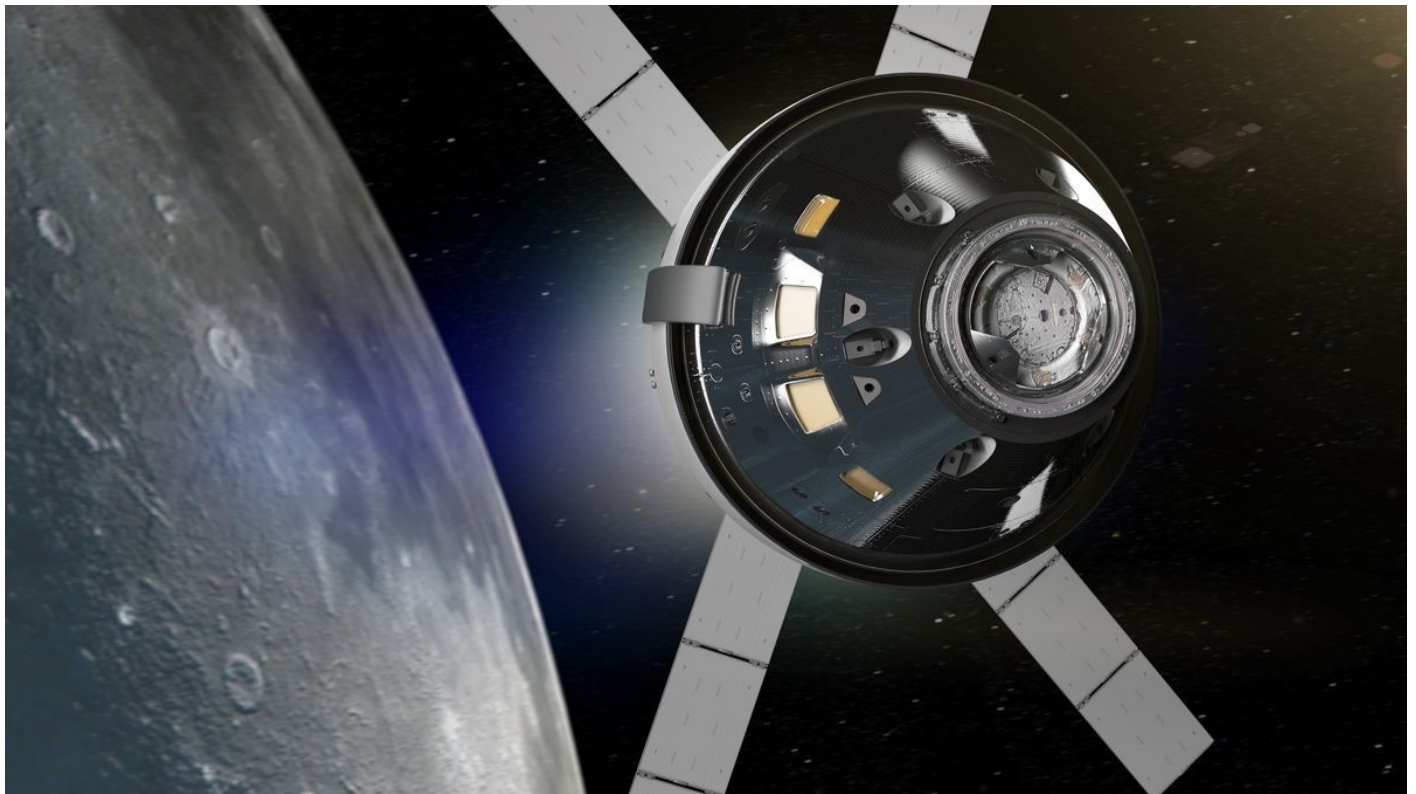

An artistic rendering of NASA's Orion capsule flying by the Moon. (NASA)



# Activity Three: Model a Spacecraft Docking System

## Student Handout

### Your Challenge

Construct and test a model of a target docking system and crew module.

### Ask and Imagine

- Why are astronauts trained on the docking system with computer simulations before they travel into space?
- What safety measures need to be taken into consideration when designing a space docking system?
- Why do NASA engineers build smaller scale models or mockups of NASA spacecraft before committing to an engineering design?

### Create

- Carefully follow the directions using the materials supplied by your teacher.
- Using measurements and mathematical ratios, you will construct a pair of docking system mechanisms, as well as a scale model of a crew module. One docking adapter will be attached to your crew module, and the other will be attached to a surface to simulate a target docking adapter.
- After completion, you will coordinate with your team to carefully maneuver the crew module in order to successfully “dock” with the target docking adapter.
- In space, the crew module would be attached to the service module until the spacecraft is ready to reenter Earth’s atmosphere. For this challenge, the service module has been eliminated to give you a clearer view of the target docking adapter.

### Building the Docking Adapters

1. Place one foam cup upside down on a table. Using a metric ruler and a pen, draw a line 3 cm high all the way around the cup. You can do this by holding a pen against the cup at the 3-cm mark and having a partner turn the cup while you hold the pen in place. Repeat for the second foam cup.
2. Use your markings as your guide and carefully cut off the tops of both cups. The 3-cm-tall rings will become the bases of your two docking adapters.



For the rest of the challenge, you will be measuring the parts you have created and using ratios to calculate the sizes of other parts you will need. You will be making six “petals” for your docking adapters (three for each adapter), all from a single ring cut from a foam cup. These isosceles trapezoidal structures help align the two docking adapters during docking. Make sure to take careful measurements and record them in your tables.

3. The height of the ring will be based on the diameter of the top of the docking adapter bases created in Step 1. The ratio of the docking adapter diameter to petal height is 1 to 0.3. First, measure the diameter of the top of the docking adapter ring to the nearest 0.1 cm (the nearest mm). Copy the following table on the paper provided by your teacher and record the diameter. Next, multiply the measurement by 0.3 to find the height of the petals. Round this number to the nearest 0.1 cm and record it in your table.

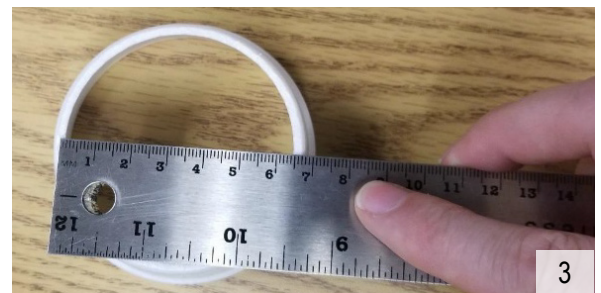

Diameter of docking adapter base, cm	Ratio	Height of petals, cm
	1:0.3	

## Crew Transportation With Orion

4. Take one of the two cups that you previously cut and place it upside down on the table. As in Step 1, use a metric ruler to mark a ring around the cup, this time **at the petal height that you just calculated**. Carefully cut off the top of the cup to create a ring, just as



5. On the last page of this activity is a template of a circle divided into sixths. To divide your ring into six equal parts, place it on the template, making sure it is centered in the circle. Have one team member hold the ring in place while another draws a vertical line where each mark meets the ring.

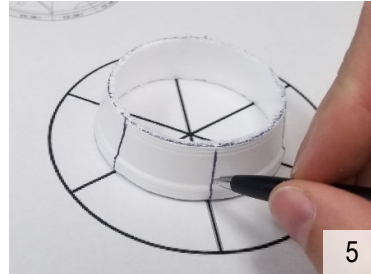

6. Using scissors, carefully cut along each vertical line, dividing the ring into six equal pieces. As you cut them out, keep them organized right side out and with the longer side on the bottom.

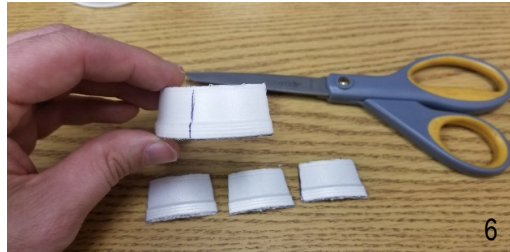

7. Because each petal is shaped like a trapezoid, the top of each petal will need to be shorter than its base. The top of each petal is about half the length of its base, or a ratio of **1 to 0.5**. To keep the petal the shape of an isosceles trapezoid, trim the remaining half from the top in equal fourths (or a ratio of **1 to 0.25**) from each side.



8. Carefully measure the length of the base of one of the petals. Copy the following table on the paper provided and record the length of the base. Then use the ratios to calculate the length of the top of each petal and how much needs to be trimmed from each side.

Length of petal base, cm	Ratio of petal base to petal top	Length of petal top, cm
	1:0.5	
Length of petal base, cm	Ratio of petal base to trim length	Length to trim off each side, cm
	1:0.25	

### Fun Fact

NASA collaborated with international space agencies and private aerospace companies to establish the International Docking System Standard (IDSS). The NASA Docking System (NDS) is the implementation of the IDSS. Spacecraft using the NDS can dock with other pressurized spacecraft using the same system and share air, water, power, communications, and even fuel resources.

Learn more:

<https://www.youtube.com/watch?v=iHomPzdPcH4>

### Career Corner

Do you have a passion for making scale models in your spare time? Take your hobby and skills to new heights at NASA! You can become an engineer at NASA's Subscale Research Lab and build models to test new and innovative prototypes of the next generation of spacecraft or aircraft.

Learn more:

<https://www.youtube.com/watch?v=H7Oixa8Nqrg>



9. Using the length you calculated to trim off each side of the top of each petal, measure inward from the outside edge of each side and make a mark.
10. Using your ruler as a straight edge, draw diagonal lines from the marks you made to the outer edge of the base on each side of the petal.
11. Finally, using scissors, carefully cut along the diagonal lines to complete each petal.
12. To attach the petals to your docking adapter, they need to be properly aligned. Take one of the docking adapter bases you completed earlier and place it upside down on the circle template you used in Step 5. While one person in your team holds it in the center, make a mark at the bottom of the docking adapter base where each line from the template meets the docking adapter base. Repeat this for the second docking adapter base.
13. Flip one of your docking adapter bases over. Hold one of the petals on top of the base as shown in the photo (13) making sure it is centered between two of the marks you made. Secure the petal to the base using tape.
14. Repeat this step two more times for this docking adapter, leaving a gap between each petal. When complete, your docking adapter should look like the photo (14). Check that your petals will bend inward when gently pressed and spring outwards when released. Repeat this process (Steps 4 through 14) to complete your other docking adapter.
15. Congratulations! You have completed a matching pair of docking adapter mechanisms. Now check to see if they will dock. Place one docking adapter face up on the table, hold the other upside down, and rotate 180 degrees. Slowly lower one docking adapter onto the other until their bases touch. The petals should bend inward slightly as the two docking adapters “dock.”

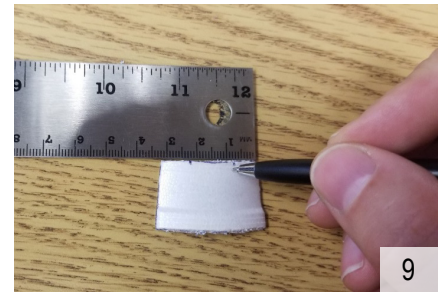

9

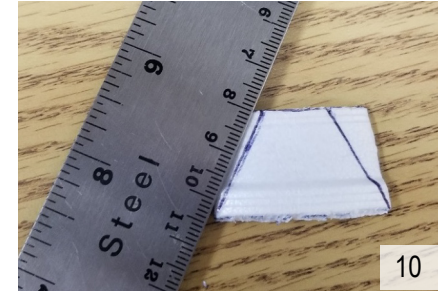

10

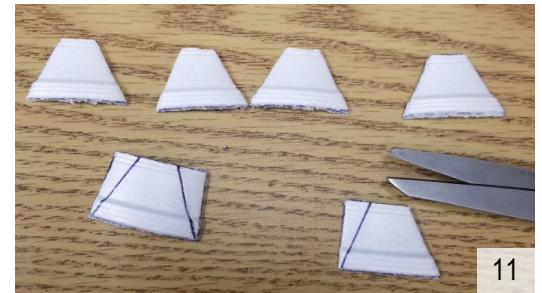

11



12



13



14

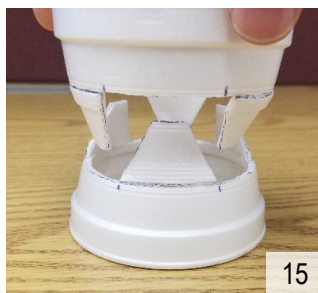

15

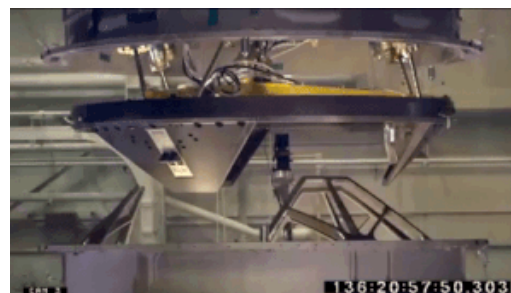

Two NASA Docking Adapter prototypes being tested.  
(NASA)

# Crew Transportation With Orion

## Building the Crew Module Scale Model

Now that you have your two docking adapters completed, it is time to construct a scale model of the crew module to test vehicle docking. Your crew module will use one of the docking adapters you have already constructed. You will also need to make a base plate and six stanchions.

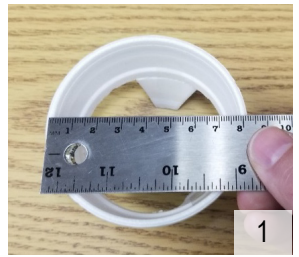

- To make these components, you will need to measure the diameter of the bottom of your docking adapter. Copy the following table on the paper provided and record the diameter.

Diameter of bottom of docking adapter, cm	Ratio of docking adapter diameter to heat shield diameter	Heat shield diameter, cm
	1:2.7	
Heat shield diameter, cm	Ratio of heat shield diameter to heat shield radius	Heat shield radius, cm
	1:0.5	
Diameter of bottom of docking adapter, cm	Ratio of docking adapter diameter to stanchion length	Length of stanchion, cm
	1:1.6	

### Heat Shield

- The diameter of the heat shield will be 2.7 times the diameter of the bottom of the docking adapter, or a ratio of 1 to 2.7. Once you have calculated the diameter of the heat shield and recorded it on your table, you will make a circle of that diameter on your sheet of construction paper. First, you will need to find the radius of the circle, which is one-half of the diameter, or a ratio of 1 to 0.5. Record this on your table.
- Next, you will use the heat shield radius you calculated to make a circle on your sheet of construction paper. You can use a compass to make the circle or you can use the string method shown in the photos (3 and 4). String method: Make a small dot in the center of your paper. Tie a string near the end of a pencil and measure out the length of the radius of the heat shield along the string, beginning at the tip of the pencil. Place a small mark on the string so you do not lose its place.
- Place the mark you made on the string onto the dot you made in the center of the paper and stretch the pencil out to full length. While a member of your team holds the paper steady, keep the mark you made on the string in place as you rotate the pencil around in a complete circle.
- After completing the circle for the heat shield, cut it out and place one of the docking adapters directly in the middle. Have one person on the team hold the docking adapter in place while another traces a circle onto the heat shield around the docking adapter.
- When completed, carefully cut out the circle. The hole in the heat shield will allow you to see through the crew module from behind, aiding in docking.

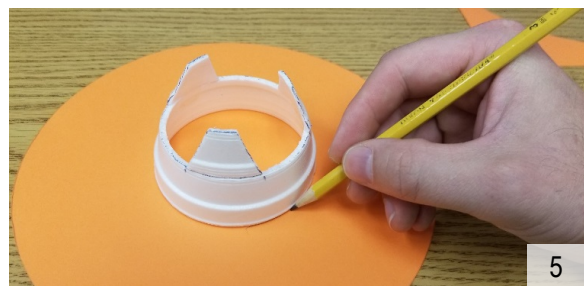
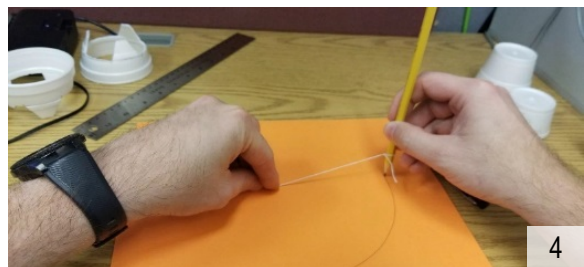



## Stanchions

7. Next, you will measure for the six stanchions that will act as the skeletal support of your crew module. Their length is based on the diameter measurement of the bottom of the docking adapter that you recorded earlier. The ratio of the diameter of the bottom of the docking adapter to the length of the stanchions is 1 to 6. Calculate this length and record it on your table from Step 2.

8. Once you have calculated and recorded the stanchions' length, measure out the length onto each straw, beginning at the edge of the flexible joint, and toward the long end, as shown in the picture (8). Do not measure from the end of the straw! After marking each straw, cut them on your mark.

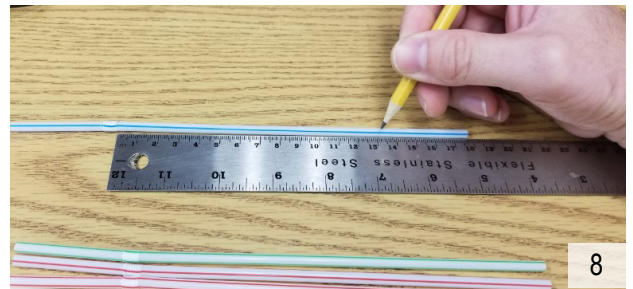

9. After cutting each straw, set them aside and retrieve the circle template used in Steps 5 and 12 of Building the Docking Adapter. You will use it to align your stanchions equally around the heat shield. Place the heat shield over the template, making sure that it is centered. Retrieve one of your stanchions and locate the end that has the shorter distance to the flexible joint. Place this end on the heat shield with the flexible joint at the edge of the circle, and the end of the straw in line with one of the lines on the template. Tape the straws into place.

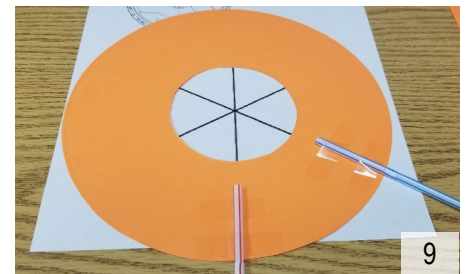

10. Repeat this process until all your stanchions have been taped down in a circular pattern. After completing this, you can remove the template. Next, extend the flexible joint in each straw, and bend the straws vertically.

11. It is now time to attach one of your docking adapters to the crew module. Retrieve one of the docking adapters and place it behind one of the stanchions so that the top of the stanchion overlaps the lip of the cup and is aligned with one of the marks you made earlier to align the petals.

12. Loosely tape the stanchion into place, and repeat the process with the stanchion on the opposite side of the crew module. Center the docking adapter at the top of the crew module. You may need to readjust the tape to get it centered.

13. Attach the four stanchions in the same manner to complete your crew module.

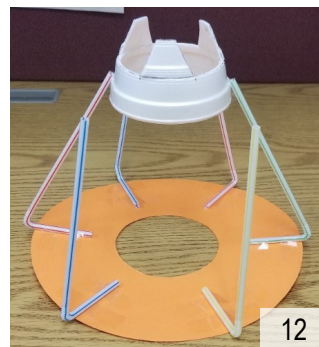
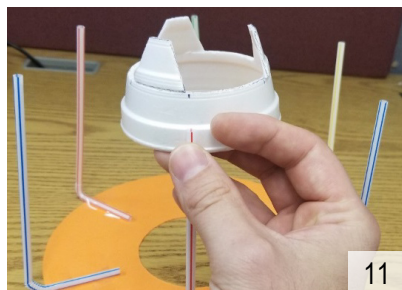
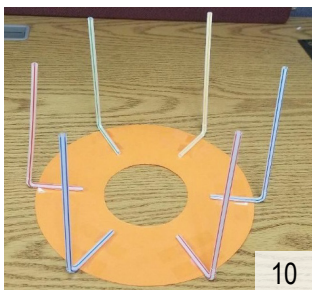

## Crew Transportation With Orion

### Control System

14. Now you will need to create a control system to make the crew module maneuverable for docking. Cut four pieces of string about 1 m in length each. Tie the end of the first string to the flexible joint of one of the stanchions. Tie the end of the second string to the flexible joint of the stanchion on the opposite side of the crew module. Tie the ends of the third and fourth strings to these same stanchions, but at the top, near the docking adapter. It may be helpful to tape the two top strings to prevent them from sliding down.



15. From the template page, cut out the round top-view docking adapter image. The shape in the middle is a docking target that is mounted to the exterior hatch inside the docking adapter. It aids astronauts in properly aligning the spacecraft for docking. After cutting out the image, place it on the bottom of your second docking adapter with the image facing the opening. Align the petals in the image with the petals on your docking adapter and tape the image into place.

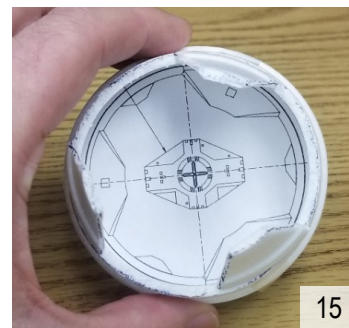

Congratulations! You have completed your crew module scale model as well as a target docking adapter. You are now ready to begin your docking training and missions.

### Plan, Test, and Improve

Now that you have completed your crew module with the docking adapter attached, as well as a second docking adapter with the docking target installed, it is time to learn how to maneuver your crew module and dock with another object. You probably already know that spacecraft can move in three dimensions in the direction of each axis. They can move forward and backward, up and down, and left and right. In order to orient themselves in line with the docking hatch on another craft, they also need to be able to turn on three different axes of rotation. These three turns are called pitch, turning the nose of the craft up or down; yaw, turning the nose of the craft left and right; and roll, spinning the nose of the craft clockwise or counterclockwise. Study these maneuvers in the diagram shown here and picture your crew module moving in the same way.

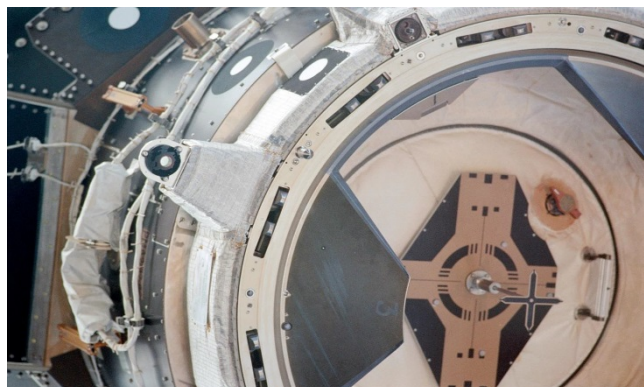

Docking target inside one of the docking adapters aboard the International Space Station.

### Docking Simulation

Your crew module is maneuvered by two copilots. Facing each other, each pilot holds two strings on opposite sides of the crew module. The pilots will pull the strings, but not hard enough for them to be pulled loose. A third member of your team will act as the commander and give verbal commands on how to maneuver the crew module into docking position. Your crew module will be successfully “docked” when its docking system petals are interlocked with those on the target docking system. These missions will require teamwork and communication. Good luck!

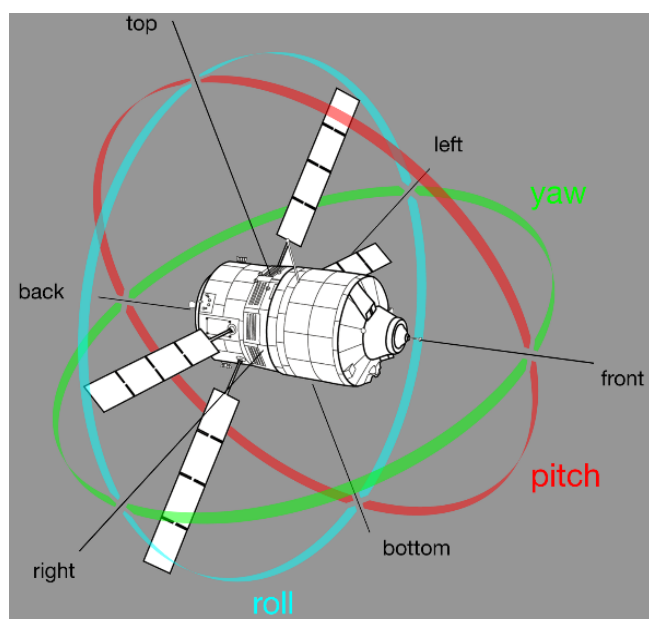

Depiction of roll, pitch, and yaw on an uncrewed cargo spacecraft. (ESA-I/Baroncini)



## Training Missions

- Copilots practice holding the crew module steady in midair with the nose facing forward, down, and upside down.
- Copilots hold the crew module steady while the commander presses the other docking system onto the crew module so the pilots can feel how much pressure needs to be applied for a successful dock.
- Copilots practice the following 12 maneuvers as given to them by their commander: move up, move down, move left, move right, move forward, move backward, pitch up, pitch down, yaw left, yaw right, roll clockwise, roll counterclockwise.

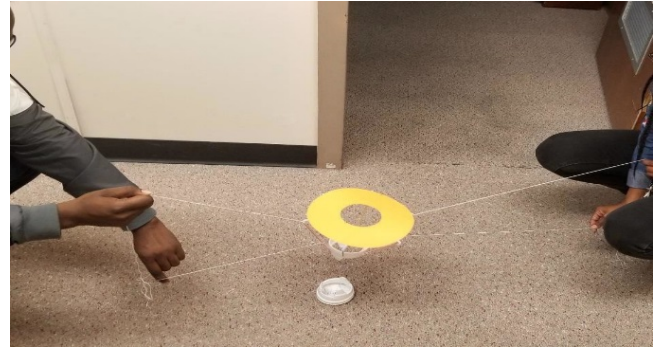

## Rookie Missions

- Place your target docking system facing upward on a flat surface (it may help to tape it down). Copilots maneuver the crew module, following commands from the commander, and successfully dock.
- Using tape, place the target docking system on a wall or other vertical surface. Copilots maneuver the crew module, following commands from the commander, and successfully dock.
- Place your target docking system, facing upward on a flat surface (it may help to tape it down). Copilots with blindfolds maneuver the crew module, following commands from the commander, and successfully dock.



## Veteran Missions

- Using tape, place the target docking system on a wall or other vertical surface. Copilots with blindfolds maneuver the crew module, following commands from the commander, and successfully dock.
- Using tape, place the target docking system at an angle on a table corner or other surface. Copilots maneuver the crew module, following commands from the commander, and successfully dock.
- Partner with another team and successfully dock your two crew modules together midair.

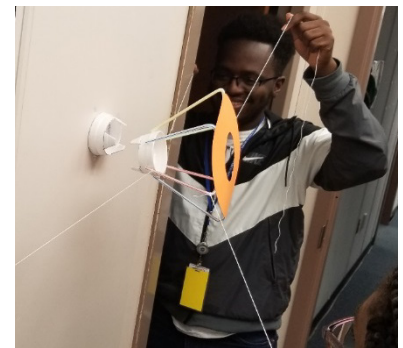

## Expert Missions

- Using tape, place the target docking system at an angle on a table corner or other surface. Copilots with blindfolds maneuver the crew module, following commands from the commander, and successfully dock.
- Partner with another team and successfully dock your two crew modules together midair with blindfolded copilots.
- Partner with another team. Place the target docking system in various locations in the room and challenge each other to dock with the target, with blindfolded copilots, in the shortest amount of time or with the fewest number of commands given by the commander.

## Share

- What was the greatest challenge for your team today?
- Why was it important for your measurements and calculations to be accurate?
- The diameter of the spacecraft's heat shield is 5.03 m. What is the scale of your model?
- Was your team successful when maneuvering your crew module model into the docking port? Why or why not?
- When spacecraft dock, they do not just share a physical airtight seal. There are also electrical and plumbing connections that can be made. What resources could be shared between two docked spacecraft?
- If you were to participate in this activity again, what would you do differently?

Activity Three Templates

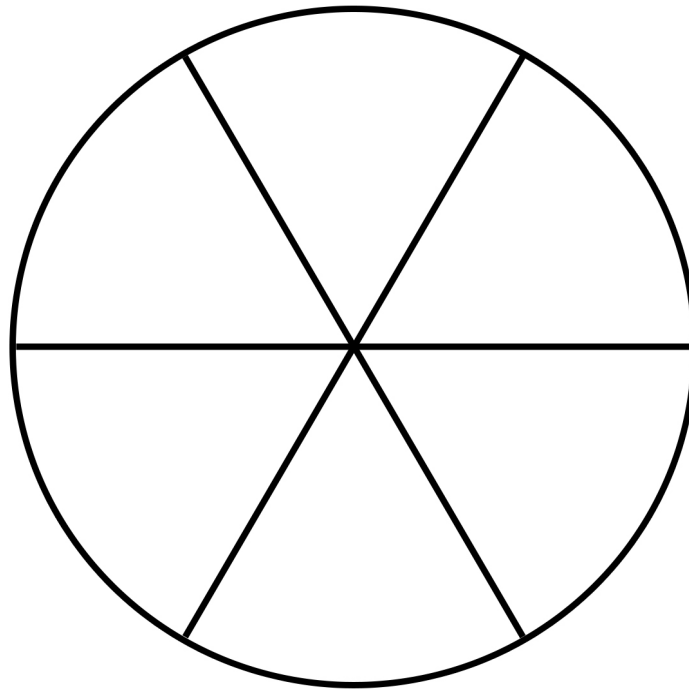

# Activity Four: Build a Heat Shield

## Educator Notes

### Challenge

Students will work together as a team to design and build a heat shield that will protect the contents (candy) of a crew module (paper cup) from a simulated atmospheric reentry (hair dryer).

### Suggested Time

60 minutes

### Learning Objectives

Students will

- Apply the steps of the engineering design process to successfully complete a team challenge.
- Design, build, and test a crew module heat shield.
- Explore concepts related to heat transfer, heat load, thermal resistance, and turbulence.
- Brainstorm ideas about what material characteristics will best protect the contents (candy) of the simulated crew module.
- Make observations and collect data to improve their design.

### Curriculum Connection

Science and Engineering (NGSS)	
<p><i>Disciplinary Core Ideas</i></p> <ul style="list-style-type: none"> <li>• MS-PS3-3 Energy: Apply scientific principles to design, construct, and test a device that either minimizes or maximizes thermal energy transfer.</li> <li>• MS-PS3-4 Energy: Plan an investigation to determine the relationships among the energy transferred, the type of matter, the mass, and the change in the average kinetic energy of the particles as measured by the temperature of the sample.</li> <li>• MS-ETS1-1 Engineering Design: Define the criteria and constraints of a design problem with sufficient precision to ensure a successful solution, taking into account relevant scientific principles and potential impacts on people and the natural environment that may limit possible solutions.</li> <li>• MS-ETS1-3 Engineering Design: Analyze data from tests to determine similarities and differences among several design solutions to identify the best characteristics of each that can be combined into a new solution to better meet the criteria for success.</li> </ul> <p><i>Crosscutting Concepts</i></p> <ul style="list-style-type: none"> <li>• System and System Models: A system is an organized group of related objects or components; models can be used for understanding and predicting the behavior of systems.</li> <li>• Energy and Matter: Tracking energy and matter flows into, out of, and within systems helps one understand their system's behavior.</li> <li>• Interdependence of Science, Engineering, and Technology: Engineering advances have led to important discoveries in virtually every field of science, and scientific discoveries have led to the development of entire industries and engineered systems.</li> </ul>	<p><i>Science and Engineering Practices</i></p> <ul style="list-style-type: none"> <li>• Asking Questions and Defining Problems: A practice of science is to ask and refine questions that lead to descriptions and explanations of how the natural and designed world works and which can be empirically tested.</li> <li>• Developing and Using Models: A practice of both science and engineering is to use and construct models as helpful tools for representing ideas and explanations. These tools include diagrams, drawings, physical replicas, mathematical representations, analogies, and computer simulations.</li> <li>• Planning and Carrying out Investigations: Scientists and engineers plan and carry out investigations in the field or laboratory, working collaboratively as well as individually. Their investigations are systematic and require clarifying what counts as data and identifying variables or parameters.</li> <li>• Analyzing and Interpreting Data: Scientific investigations produce data that must be analyzed in order to derive meaning. Because data patterns and trends are not always obvious, scientists use a range of tools—including tabulation, graphical interpretation, visualization, and statistical analysis—to identify the significant features and patterns in the data. Scientists identify sources of error in the investigations and calculate the degree of certainty in the results. Modern technology makes the collection of large data sets much easier, providing secondary sources for analysis.</li> </ul>
Technology (ISTE)	
<p><i>Standards for Students</i></p> <ul style="list-style-type: none"> <li>• Knowledge Constructor: Students critically curate a variety of resources using digital tools to construct knowledge, produce creative artifacts, and make meaningful learning experiences for themselves and others.                             <ul style="list-style-type: none"> <li>– 3d: Students build knowledge by actively exploring real-world issues and problems, developing ideas and theories, and pursuing answers and solutions.</li> </ul> </li> <li>• Innovative Designer: Students use a variety of technologies within a design process to identify and solve problems by creating new, useful, or imaginative solutions.                             <ul style="list-style-type: none"> <li>– 4a: Students know and use a deliberate design process for generating ideas, testing theories, creating innovative artifacts, or solving authentic problems.</li> </ul> </li> </ul>	<p><i>Standards for Students (continued)</i></p> <ul style="list-style-type: none"> <li>– 4c: Students develop, test, and refine prototypes as part of a cyclical design process.</li> <li>– 4d: Students exhibit a tolerance for ambiguity, perseverance, and the capacity to work with open-ended problems.</li> <li>• Global Collaborator: Students use digital tools to broaden their perspectives and enrich their learning by collaborating with others and working effectively in teams locally and globally.                             <ul style="list-style-type: none"> <li>– 7c: Students contribute constructively to project teams, assuming various roles and responsibilities to work effectively toward a common goal.</li> </ul> </li> </ul>
Mathematics (CCSS)	
<p><i>Mathematical Practices</i></p> <ul style="list-style-type: none"> <li>• CCSS.MATH.PRACTICE.MP1: Make sense of problems and persevere in solving them.</li> </ul>	<p><i>Mathematical Practices (continued)</i></p> <ul style="list-style-type: none"> <li>• CCSS.MATH.PRACTICE.MP3: Construct viable arguments and critique the reasoning of others.</li> </ul>

## Crew Transportation With Orion

### Preparation Time

15 minutes

- Read the Introduction and Background, Educator Notes, and Student Handout to familiarize yourself with the activity.
- Print copies of the Student Handout.
- Gather and prepare all supplies listed on the materials list.
- The wire mesh or wire cloth (often referred to as “hardware cloth” or “welded wire fabric”) can be found online or in local hardware stores. Any type can be used, but ideally it will be able to give structure to the shield device and not conduct the heat. This is a major design element. If the activity budget allows, offer a variety of wire mesh or cloth materials, and students can test to determine which material works best.
- Set up testing stations with safety equipment, hair dryer, tongs, infrared thermometer (recommended), scale, and a metric ruler. One station for every two or three teams is recommended.

### Materials

- Copies of Student Handout and blank paper
- Paper and pencil
- Scissors
- Tape
- Metric rulers
- 5-oz paper cups (1 per team)
- Digital scale or balance
- Hair dryer (1 per testing station)
- Tongs (1 per testing station)
- Stopwatch (1 per testing station)
- Thermometers (2 per testing station; infrared is recommended)
- Oven mitts or gloves (2 per testing station)
- Eye protection (for every student)
- Unwrapped candy bars without nuts (Mini, nugget, or fun size, at least 2 per team; for consistency, use the same type for the whole class. Nuts interfere with the temperature probes.)

General building supplies (choose a selection of materials to test):

- Wire mesh or wire cloth (see Preparation Time)
- Index cards, newspaper, construction paper
- Cotton balls
- Bubble wrap
- Electrical tape
- Steel wool
- Spackling compound
- White glue
- Styrofoam™ scraps (packing peanuts, food trays, plates)
- Cardboard scraps (milk cartons, shoeboxes, coffee cups, boxes)

### Introduce the Challenge

- Provide context for this activity using the Introduction and Background information in this guide. Use the Additional Resources listed at the end of the Educator Notes to engage

### Share With Students



#### Brain Booster

Avcoat, an ablative material installed on the base of the heat shield, is designed to erode and move heat away from the crew module, protecting the astronauts inside from searing temperatures experienced while reentering Earth’s atmosphere.

Learn more:

<https://www.nasa.gov/content/partnerships-make-missions-possible>



#### On Location

Inside the world’s largest vacuum chamber and premier space environments test facility at NASA’s Plum Brook Station in Sandusky, Ohio, spacecraft are subjected to extreme temperatures, ranging from –160 to 150 °C (–250 to 300 °F), to simulate extreme in-space conditions. The facility also has the capability to test for electromagnetic interference and compatibility.

Learn more:

<https://www.nasa.gov/feature/orion-to-face-simulated-rigors-of-space-in-last-major-testing-before-artemis-i>

and inform students about this challenge. Emphasize why a heat shield is a crucial element of a spacecraft, especially one that carries people.

- Explain the role of engineers in designing technology to solve problems. Share the NASA for Kids video [Intro to Engineering](#) and introduce the engineering design process.
- Explain that engineers not only seek to solve problems, they also look for designs that are cost effective and can be developed in a reasonable time period.
- Divide the class into teams (three to five students) and distribute the Student Handout to each team. Explain the details of the challenge, including the design constraints and your expectations for teamwork and classroom management.

### Design Constraints

1. The surface area of the heat shield cannot exceed 40 cm<sup>2</sup>.
2. The heat shield must protect the interior contents of the crew module (candy) from heat and turbulence during the simulated reentry (hair dryer).
3. The contents must survive for 7 minutes without melting.

### Facilitate the Challenge

#### Ask, Imagine, and Plan

- Discuss the concepts of heat transfer, heat load, thermal resistance, friction, and turbulence.
- Engage teams to brainstorm ideas about what material characteristics will work best to protect the contents (candy) of the simulated crew module.
- Encourage students to draw out their ideas for a heat shield and plan how they will conduct the testing.

#### Create, Test, and Improve

1. Each team of students will build the heat shield they designed, using the materials provided.
2. Once the heat shield has been built, students will test the shield by holding a hair dryer no more than 10 cm away from the bottom of the shield, exposing it to direct heat and air for 7 minutes.



#### Safety

- To prevent burns, students should use tongs and oven mitts or gloves to hold the heat shield and hair dryer.
  - Use caution when operating hair dryers. Do not touch the hot parts of the hair dryer or heat shield.
  - Be aware of candy and nut allergies. Other materials such as wax or ice could be used instead of candy bars.
3. Students will use a stopwatch and take thermometer readings in 1-minute increments. They will track their data on the Student Handout.
  4. After completing the first round of testing, students will make modifications to their designs to improve protection of the crew module contents (candy) based on the results of the testing and their understanding of scientific concepts, including transfer of energy, thermal resistance, and heat transfer.
  5. Students will repeat the testing with their modified design.

#### Share

Engage students with the following discussion questions:

- Which design characteristics provided the most protection to the crew module?
- In what ways were you able to manage your time in order to get the best results?
- What information could engineers working on this project learn from your team's results?
- What other tests or calculations could you do before making your recommendations to NASA's engineering team?

#### Extensions

- Repeat the activity using different types of heat-sensitive materials, such as wax or ice, as your "cargo" inside the crew module (instead of candy).



## Crew Transportation With Orion

- Add a cost constraint to the challenge and create a budget for students to “purchase” materials. Assign cost to all materials based on mass, area, or type of material.
- Ask teams to determine under what conditions their design will fail, or the maximum heat load on their design.

### Reference

Modified from Mars Science Laboratory Entry, Descent, and Landing Instrument (MEDLI) activity:

[https://www.nasa.gov/sites/default/files/best\\_medli\\_workbook.pdf](https://www.nasa.gov/sites/default/files/best_medli_workbook.pdf)

### Additional Resources

- Web page: Orion Spacecraft. <https://www.nasa.gov/exploration/systems/orion/index.html>
- Photo: Orion’s heat shield. <https://www.nasa.gov/image-feature/heat-shield-for-first-artemis-mission-with-astronauts-arrives-at-kennedy>
- Video: Orion: Heat Shield. <https://www.youtube.com/watch?v=XH4VVpfr9Bs>
- Video: Career Connection: NASA Heat Shield Engineer. <https://www.youtube.com/watch?v=qmDlp6FW2eE>
- Digital Badging: Online NASA STEM Learning. <https://www.txstate-epdc.net/digital-badging/>



Artist's rendering of Orion spacecraft reentry. (NASA)



# Activity Four: Build a Heat Shield

## Student Handout

### Your Challenge

Design a heat shield to protect the contents of a crew module during a simulated atmospheric reentry.

### Design Constraints

1. The surface area of the heat shield cannot exceed 40 cm<sup>2</sup>.
2. The heat shield must protect the interior contents of the crew module (candy) from heat and turbulence during the simulated reentry (hair dryer).
3. The contents must survive for 7 minutes without melting.

### Ask, Imagine, and Plan

- You will be given a paper cup to serve as the crew module and a small piece of candy to simulate the sensitive contents within the crew module.
- After the heat shield is built, it needs to be securely attached to the open end of the cup (the bottom of your crew module) with the unwrapped piece of candy inside.
- Your team will be responsible for documenting observations and temperatures (internal and external) once per minute. Include in your design a window or hole in the top of the crew module so you can observe any changes.
- Brainstorm ideas and sketch your heat shield on the blank paper your teacher provided. Be sure to label it with the materials you plan on using. What is the general shape of your heat shield? What types of material will best protect the contents inside?

### Create

- Build your heat shield using only the materials provided.

### Test and Improve

1. You will conduct a 7-minute test on the heat shield under the direction and supervision of your teacher. For safety, use tongs when handling the crew module and heat shield. The heat source (hair dryer) should not be more than 10 cm from the bottom of the heat shield.
2. On a sheet of paper, create a table like the example shown below. At 1-minute intervals, note your observations of what is happening to the candy while the test is taking place. Use the thermometer to take temperature readings of the inside of the module and the bottom of your heat shield. Record your results and observations in your table.

Time increments (minutes)	External temperature ( C or °F)	Internal temperature ( C or °F)	Observations
1:00			
2:00			
3:00			
4:00			
5:00			
6:00			
7:00			



### Fun Fact

Did you know that Orion reentered Earth’s atmosphere at a speed of more than 32,000 km/h (20,000 mph) before splashdown during Exploration Flight Test 1? The heat shield endured temperatures of nearly 2,200 °C (4,000 °F), which is almost twice as hot as molten lava!

Learn more:

<https://www.youtube.com/watch?v=KyZqSWWKmHQ>



### Career Corner

If you become a scientist or engineer in NASA’s Advanced Thermal Technologies branch, you can research how various materials could be used to regulate and maintain safe temperatures inside a spacecraft, protecting the crew and the equipment in the extreme environment of space.

Learn more:

<https://www.nasa.gov/careers/engineering>

## Crew Transportation With Orion

3. Improve the design of your heat shield and repeat the experiment. Make another table like the one above and record your new results and observations.

### Share

- Which design characteristics provided the most protection to the crew module contents?
- In what ways were you able to manage your time in order to get the best results?
- NASA engineers must also determine under what conditions their designs might fail. By learning the maximum heat load on their design, engineers can identify what other conditions this technology could be used with (hotter temperatures, longer reentries, etc.). Based on the data you collected in the 7-minute tests, how much longer do you think your design would be able to handle the turbulence and thermal stress?



Installation of the heat shield on NASA's Orion spacecraft crew module at Kennedy Space Center in Florida on July 25, 2018. (NASA/Kim Shiflett)

# Appendix: STEM Standards and Practices

## Next Generation Science Standards (NGSS)

<https://www.nextgenscience.org/>

Alignment of Activities With NGSS Disciplinary Core Ideas				
Motion and Stability (MS) Standard	Analyze the Geometry of a Spacecraft	Design a Crew Module	Model a Spacecraft Docking System	Build a Heat Shield
<b>Forces and Interactions</b>				
MS-PS2-2			✓	
<b>Energy</b>				
MS-PS3-3				✓
MS-PS3-4				✓
<b>Engineering Design</b>				
MS-ETS1-1		✓		✓
MS-ETS1-2		✓		✓
MS-ETS1-4		✓		

Alignment of Activities With NGSS Crosscutting Concepts				
Concept	Analyze the Geometry of a Spacecraft	Design a Crew Module	Model a Spacecraft Docking System	Build a Heat Shield
Patterns				
Cause and Effect				
Scale, Proportion, and Quantity				
System and System Models		✓	✓	✓
Energy and Matter				
Structure and Function		✓	✓	✓
Stability and Change				
Interdependence of Science, Engineering, and Technology	✓	✓		✓
Influence of Engineering, Technology, and Science on Society and the Natural World				

## NGSS Science and Engineering Practices

<https://ngss.nsta.org/PracticesFull.aspx>

Alignment of Activities With NGSS Science and Engineering Practices				
Practice	Analyze the Geometry of a Spacecraft	Design a Crew Module	Model a Spacecraft Docking System	Build a Heat Shield
Asking Questions and Defining Problems		✓		✓
Developing and Using Models		✓	✓	✓
Planning and Carrying out Investigations		✓		✓
Analyzing and Interpreting Data	✓			✓
Using Mathematics and Computational Thinking	✓		✓	
Constructing Explanations and Designing Solutions		✓		
Engaging in Argument From Evidence				
Obtaining, Evaluating, and Communicating Information				

## International Society for Technology in Education (ISTE) Standards for Students

<https://www.iste.org/standards/for-students>

Alignment of Activities With ISTE Standards for Students				
Standard	Analyze the Geometry of a Spacecraft	Design a Crew Module	Model a Spacecraft Docking System	Build a Heat Shield
Knowledge Constructor				
3d				✓
Innovative Designer				
4a		✓		✓
4c		✓		✓
4d		✓		✓
Computational Thinker				
5c	✓		✓	
Global Collaborator				
7c		✓	✓	✓

## Common Core State Standards (CCSS) for Mathematics

<http://www.corestandards.org/Math/>

Alignment of Activities With CCSS Grade Level Content Standards by Domain				
Standard	Analyze the Geometry of a Spacecraft	Design a Crew Module	Model a Spacecraft Docking System	Build a Heat Shield
<b>6th Grade</b>				
CCSS.MATH.CONTENT.6.RP.A.1			✓	
CCSS.MATH.CONTENT.6.NS.B.3	✓		✓	
CCSS.MATH.CONTENT.6.G.A.1	✓			
<b>7th Grade</b>				
CCSS.MATH.CONTENT.7.NS.A.3	✓		✓	
CCSS.MATH.CONTENT.7.G.A.1			✓	
CCSS.MATH.CONTENT.7.G.A.3	✓			
CCSS.MATH.CONTENT.7.G.B.6	✓			
<b>8th Grade</b>				
CCSS.MATH.CONTENT.8.G.C.9	✓			

Alignment of Activities With CCSS Standards for Mathematical Practice				
Practice	Analyze the Geometry of a Spacecraft	Design a Crew Module	Model a Spacecraft Docking System	Build a Heat Shield
CCSS.MATH.PRACTICE.MP1		✓		✓
CCSS.MATH.PRACTICE.MP2	✓			
CCSS.MATH.PRACTICE.MP3		✓		✓
CCSS.MATH.PRACTICE.MP4	✓			
CCSS.MATH.PRACTICE.MP5	✓		✓	
CCSS.MATH.PRACTICE.MP6	✓		✓	
CCSS.MATH.PRACTICE.MP7				
CCSS.MATH.PRACTICE.MP8				





Back cover: Artist's rendering of the European-built service module for NASA's Orion crew transport vehicle. (NASA)



**National Aeronautics and Space Administration**

NASA Headquarters

300 E Street Southwest

Washington DC 20024-3210

[www.nasa.gov](http://www.nasa.gov)

NP-2020-02-2805-HQ